

# GATE IB647

## BRONZE

125 lb. SWP-200 lb. WOG† • General Service  
 Solid Wedge Disc • Non-Rising Stem  
 Threaded Bonnet • Gland Packed • Sweat Ends

4" size has split wedge and bolted bonnet. It is not covered in MSS SP-80.

### SPECIFICATIONS

IB647	Conforms to: MSS SP-80. Type 1, Class 125, Soldered Ends.
-------	--

### MATERIAL LIST

NO.	PART	MATERIAL	SPECIFICATION
1	Body	Bronze	ASTM B 62
2	Bonnet	Bronze	ASTM B 62
3	Wedge	Bronze	ASTM B 62
4	Stem	Bronze	ASTM B 62
5	Stuff Nut	Brass	ASTM B 283 C37700
6	Check Nut	Brass	ASTM B 283 C37700
7 <sup>1</sup>	Gland	Brass	ASTM B 124 C37700
8	Wheel Nut	Brass	ASTM B 16
9	Handwheel	Mall. Iron	Commercial
10	Packing	Non-Asbestos	
11	Name Plate	Sh. Alum.	Commercial

<sup>1</sup> Not used on 1/2" and smaller.

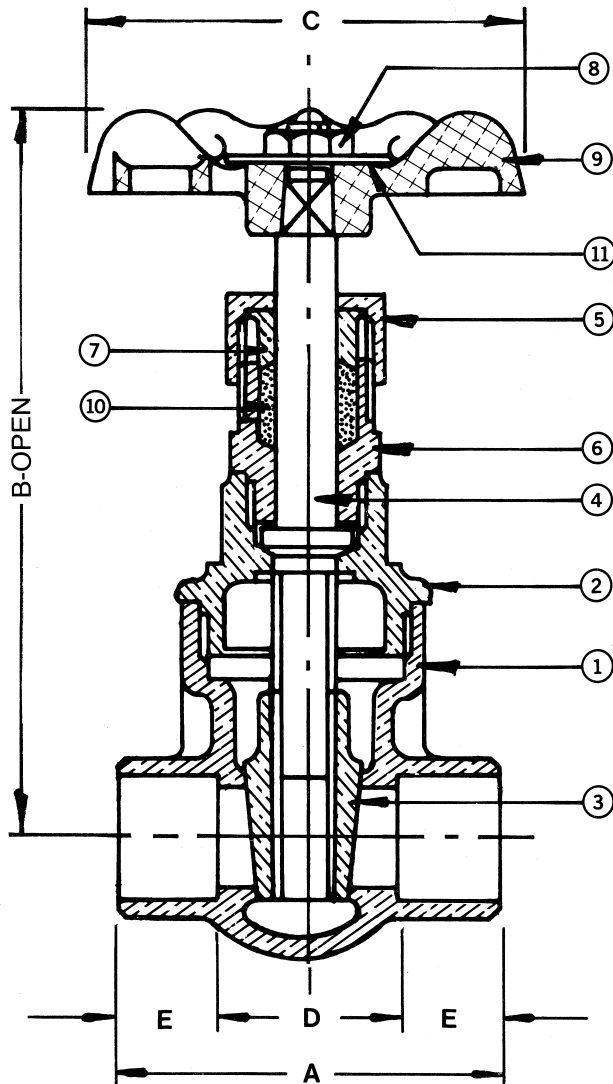

### DIMENSIONS - INCHES / MILLIMETERS

Units	Size	A	B	C	D	E
Inches	3/8	1 5/8	3 9/16	2	7/8	3/8
MM	9.53	41.28	90.50	50.80	22.23	9.53
Inches	1/2	1 7/8	3 9/16	2	7/8	1/2
MM	12.70	47.63	90.50	50.80	22.23	12.70
Inches	3/4	2 1/2	4 3/4	2 1/2	1	3/4
MM	19.05	63.50	120.65	63.50	25.40	19.05
Inches	1	3	5	2 3/4	1 3/16	29/32
MM	25.40	76.20	127.00	69.85	30.18	23.01
Inches	1 1/4	3 1/4	5 7/8	3 1/8	1 5/16	31/32
MM	31.75	82.55	149.23	79.38	33.35	24.61
Inches	1 1/2	3 5/8	6 1/2	3 1/2	1 7/16	1 3/32
MM	38.10	92.08	165.10	88.90	36.53	27.79
Inches	2	4 5/16	7 7/16	3 3/4	1 5/8	1 11/32
MM	50.80	109.55	188.93	95.25	41.28	34.13
Inches	2 1/2	4 13/16	9 1/8	4 3/4	1 7/8	1 15/32
MM	63.50	122.25	231.78	120.65	47.63	37.31
Inches	3	5 7/16	10 3/8	5 1/4	2 1/8	1 21/32
MM	76.20	138.13	263.53	133.35	53.98	42.07
Inches	4	7 1/4	15 1/2	5 1/4	2 5/32	2 15/16
MM	101.60	184.15	393.70	133.35	54.76	74.63

† Non-Shock

Rev. 1

BETTER AT EVERY TURN



**HAMMONDVALVE**

www.hammondvalve.com

The information presented on this sheet is correct at the time of publication. Hammond Valve reserves the right to change design, and/or material specifications without notice. For the most current information access [www.hammondvalve.com](http://www.hammondvalve.com)