



WALWORTH®
Since 1842



EXPANDING GATE VALVE
CATALOG

INDEX

INTRODUCTION

WALWORTH MISSION & VISION	4
WALWORTH ENGINEERING CONTROL	5
WALWORTH QUALITY SYSTEM.....	5
QUALITY CONTROL EQUIPMENT.....	9

DESIGN FEATURES

THROUGH CONDUIT RISING STEM DESIGN EXPANDING GATE VALVES	11
DISC CONFIGURATION	12
FULL OPENING THROUGH CONDUIT DESIGN	12
OPERATION DESIGN, VALVE POSITIONS	13
CONTROL ARM OPERATION	14
VENTING SYSTEMS ON BONNET	15
SEAL SYSTEM ON PACKING CHAMBER	16
DRAIN OF THE VALVE	16
EMERGENCY SEALANT INJECTOR ON PACKING CHAMBER	17
SEATS ARRANGEMENT	17
EMERGENCY SEALANT INJECTOR SYSTEM ON SEAT RINGS	18
BYPASS	18
DOUBLE BLOCK & BLEED DESIGN (DBB)	19
BIDIRECTIONAL SEATS	19
DOUBLE ISOLATION AND BLEED DIB-1 (Both seats bi-directional)	19
FINITE ELEMENT ANALYSIS AND COMPUTER-ASSISTED DESIGN	20

SLAB GATE VALVES

SOFT SEAT-METAL SEAT EXPANDING GATE VALVE	22
METAL to METAL SEAT EXPANDING GATE VALVE	23
EXPANDING GATE VALVE CLASS 150	24
EXPANDING GATE VALVE CLASS 300	28
EXPANDING GATE VALVE CLASS 600	32
EXPANDING GATE VALVE CLASS 900	36
EXPANDING GATE VALVE CLASS 1500	39
MOST COMMON TRIM ARRANGEMENTS	42
API 6D THROUGH CONDUITS EXPANDING GATE VALVE (SOFT SEAT), OPERATOR SIZING REQUIREMENTS	44

TECHNICAL INFORMATION

TYPES OF END CONNECTIONS.....	47
TYPE OF OPERATORS	48
LOCKING DEVICE	48
PRESSURE-TEMPERATURE RATINGS	49
DESIGN BASIS	52
HOW TO ORDER	53
GENERAL TERMS AND CONDITIONS	54



6D-0097



YARMOUTH RESEARCH AND TECHNOLOGY



WALWORTH

WALWORTH is one of the world's most comprehensive industrial valve manufacturers. Founded in 19th century by James WALWORTH, the Company has consistently dedicated itself to improvements in design and manufacturing of an array of valves exceptionally suited for the world's fluid control sector. We satisfy all end use industries and comprehensive customer requirements by adhering to the most demanding quality standards.

WALWORTH relies on its broad experience in supplying valves to the petrochemical, oil & gas, petroleum, power generation, pulp and paper, cryogenic and geothermal industries, among others.

Over the years, WALWORTH has produced over 40,000 different types of products and serves as a global supplier to various markets utilizing the expertise of over 500 trained employees.

Our manufacturing system includes: utilization of Company directed raw material warehouses; modern and newly acquired specialized machinery; welding processes such as SMAW, GMAW, SAW, PAW; assembly testing for all low pressure, high pressure, and at low or high temperatures; painting and coating processes; export crating and shipment.

WALWORTH is capable of providing the world's most comprehensive industrial valve line to the North American, Central American, South American, European and African markets. WALWORTH is proud to meet and satisfy the precise demands of our customers throughout the world by providing a quality product, competitive cost, and excellent service.

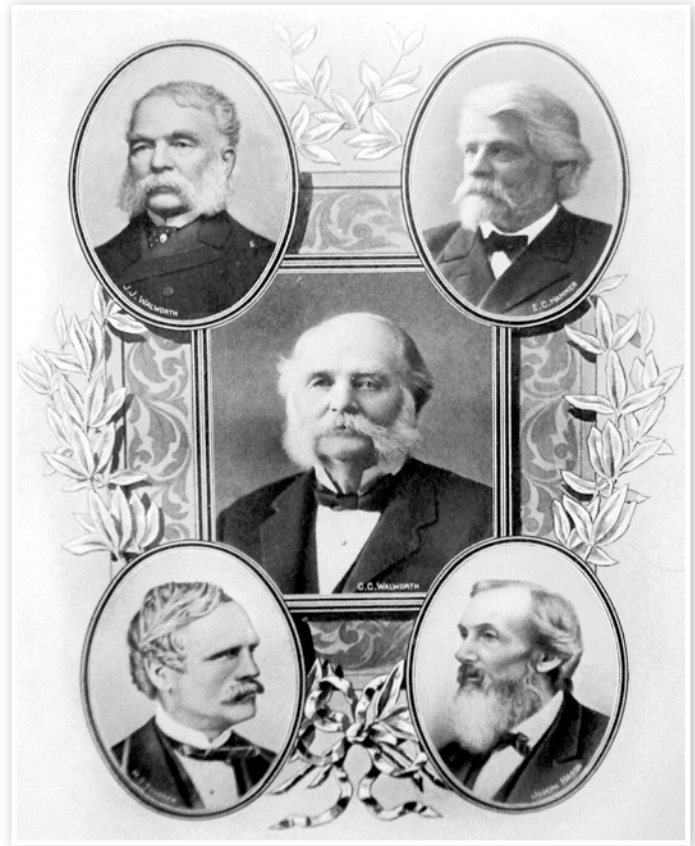

WALWORTH VALUES

MISSION

WALWORTH manufactures and supplies world-class valves and components for the flow control industry through exceptional service, competitive pricing, and consistently, on-time deliveries.



VISION

To be the world leader of unparalleled valve manufacturing and supply, WALWORTH:

- Set the standard for product quality in the flow control industry.
- Exceed the service expectations of our customers.
- Forge enduring relationships with customers, team members, and community.
- Hire, develop, and retain experienced and dedicated team members.



WALWORTH ENGINEERING CONTROL

WALWORTH products are manufactured following the strict international standards recognized all over the world, such as API, ANSI, ASME, ASTM, MSS, NACE, AWWA, BSI, CSA, among others. Our Engineering team consistently monitors updates to these standards and incorporates any applicable changes that affect the design, regulations and/or performance of our products.

Our designs are made using the most advanced technology and equipment, finite elements, and CAD system programs to ensure proper assembly and performance. From conception to calculation to detailed drawings for manufacturers, WALWORTH is a leader in development of new products that meet the needs of the current valve market.”



WALWORTH QUALITY SYSTEM

Throughout the years, WALWORTH has developed its Quality System which is an integral part of our manufacturing policy. Our primary goal is to provide products that meet and exceed market standards. In this sense, WALWORTH is an ISO-9001 Audited and Certified Company that has achieved major certifications worldwide. Our system includes the selection of raw materials from approved vendors, and rigorous oversight of our manufacturing process that is vital to quality control. The use of serial numbers allows WALWORTH the ability to not only ensure the quality of components used but to monitor and trace the fabrication process as well.



Certificate API-6D No. 6D-0097

Issued by American Petroleum Institute to apply on Gate valves, Plug valves, Ball valves and Check valves manufactured in accordance with API-6D specification.



Certificate API-6A No. 6A-0234

From American Petroleum Institute to apply on valves at PSI, 1 through 4.



Certificate API-594 No. 594-0007
 Issued by American Petroleum Institute to apply on Check Valves-Type A; Check Valves Type B manufactured in accordance with API-594 specification.



API-600 Certificate No. 600-0109
 Issued by American Petroleum Institute to apply on Bolted Bonnet Steel Gate Valves manufactured in accordance with API-600 specification.



API-602 Certificate No. 602-0024
 Issued by American Petroleum Institute to apply on Compact Steel Gate Valves, Compact Steel Globe Valves, and Compact Steel Check Valves manufactured in accordance with API-602 specification.



Certificate ISO-9001 No. 0038
 Issued by American Petroleum Institute since April 1999.



Certificate as per PED 97/23/EC Module H
 To stamp CE products.



Supplier Qualification Certificate NO. 279/13
 Issued by the Equipment and Materials Testing Laboratory, CFE (LAPEM in Spanish)



Certificate NMX-CC-9001 (Mexican Standards ISO-9001) No. 0552/2007 Issued by PEMEX in accordance with ISO-9001 Quality Assurance System.

PRODUCT CERTIFICATIONS



Emissions after 500 cycles at ambient and 350 °F
 Issued by Yarmouth Research and Technology Lab for 3 inch Class 300 Gate Valve After 500 cycles the measurement result was less than 50 ppm.



Emissions after 500 cycles at ambient and 350 °F
 Issued by Yarmouth Research and Technology Lab for 8 inch Class 300 Gate Valve After 500 cycles the measurement result was less than 50 ppm.



Emissions after 500 cycles at ambient and 350 °F
 Issued by Yarmouth Research and Technology Lab for 16 inch Class 150 Gate Valve After 500 cycles the measurement result was less than 50 ppm.





Certificates of Ultra Low Fugitive Emissions No. 20985-3, 8 & 16 in accordance with ISO-15848-1 "Industrial Valves" Measurement, Test and Qualification Procedures for Fugitive Emissions "Part 1: Classification System and Qualification Procedures for Type Testing of Valves".

TÜV Rheinland Certificate No. TRASA 700-13-0019
API-6D Trunnion mounted bolted body ball valves, carbon steel (A105-WCB) construction, double block and bleed service, primarily used but not limited to the oil and gas standard and severe applications.

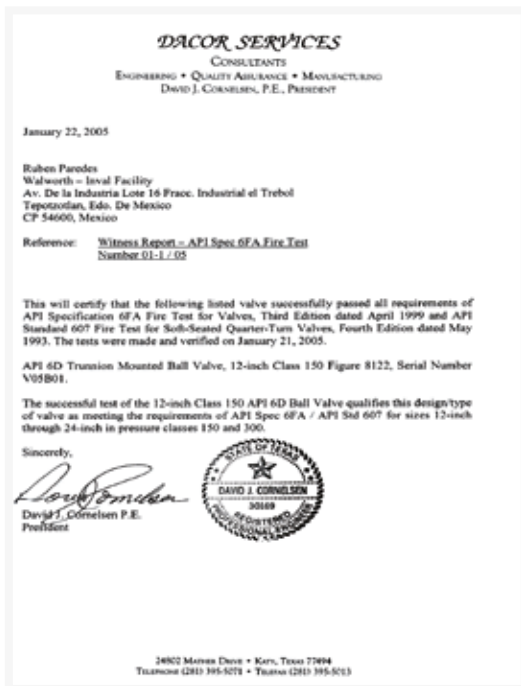

Fire Test Certificate No. 01-1/05
In accordance with API-6FA and API Standard API-607 for Trunnion Ball Valves in accordance with API-6D.

TA Luft Certificate (Fugitive Emission) Approval
ISO-5211 Top Flange, Anti-Static Device.

QUALITY CONTROL EQUIPMENT

In order to assure that WALWORTH products comply with international quality standards, in-house equipment is kept for monitoring control. Some of this equipment includes:

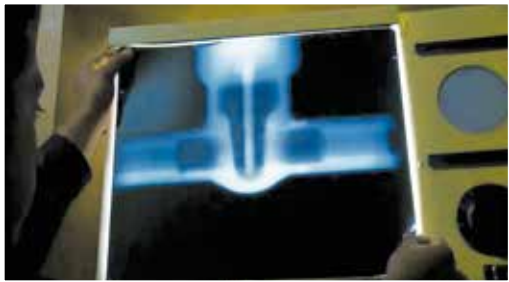

X-Ray Examination Equipment. WALWORTH has its own Ir-92 source in-house for the radiographic examination (RT) of castings from 0.100" up to 2 1/2" wall thickness to verify the soundness of the casting raw material.

PMI Equipment. A new generation of Positive Material Identification Equipment gives WALWORTH the capability to perform quick chemical analysis on incoming raw materials and on pieces after assembly, to certify that materials used were produced and assembled in accordance with WALWORTH's and our Customer's specifications.



Magnetic Particle Test. On a random basis for standard products or when a Customer requests MT Certification, WALWORTH has Magnetic Particle Test Equipment to perform on ferromagnetic materials.

Penetrant Test Examination. WALWORTH has the personnel and materials to perform PT examination by solvent removable or water washable techniques. NDT personnel are ASNT Certified.



Test Loop. A complete Laboratory Test loop exists for design validation of WALWORTH products. The test is performed at maximum design pressure, advances the valves from 3000 to 5000 cycles, and requires more than four months to complete.

Pressure Gradient Test Loop. This test exposes Plug valves to the extremes of both positive and negative pressure gradients to verify that the plug in a balanced plug design will prevent lock-up in the body.





Metrology Laboratory. WALWORTH developed a calibration and/or verification system in all of the equipment used in its facilities. This ensures our ability to trace measurements, control products, and comply with international standards.

Fire Test Facilities. WALWORTH has the facilities to perform fire tests in accordance with API requirements. The test exposes the valve to a fire flame at 1400 to 1800 °F (761 to 980 °C) to verify proper seal of the valve.



Low Fugitive Emissions Test. This test is performed when a Customer requires low fugitive emissions certification. Our Lab has its own LFE test equipment that is capable of measuring less than 20 ppm in both static and mechanical conditions at either ambient temperature or thermal cycle operations.

Ultrasonic Testing Equipment. Using ultrasonic techniques, we can detect sub surface flaws in materials and evaluate castings and forgings that cannot be radiographed. In addition, we utilize these techniques to measure the wall thickness of castings and forgings.



Tensile Test Equipment. We use this equipment to verify the mechanical properties of materials used for manufacturing. WALWORTH tests samples on a random basis even though we receive MTRs from our suppliers and foundries.

Hardness Test Equipments.- In both lab and shop tests, WALWORTH uses hardness tester equipment, such as Rockwell B, C Brinell or Vickers, to ensure compliance with specifications.



THROUGH CONDUIT RISING STEM DESIGN EXPANDING GATE VALVES

Principle of Design: The WALWORTH Expanding Gate valve is manufactured in accordance with **API-6D**. This type of valve is suitable for onshore and offshore applications where suspended and abrasive solids are present in the fluid or for oil and gas transportation and isolation service. The double block and bleed design offers a proper seal in between both seats and the gate in high and low pressure, for this reason, line pressure is not needed to seal the valve. The principle of operation is based on two segment members of an obturator which at an opened or closed position are capable to seal in both directions and isolate the central cavity.

WALWORTH offers this product line in the following base materials.

- a) Carbon steel as per ASTM A216 grades WCB, WCC.
- b) Carbon steel for NACE applications as per ASTM A216 grade WCB with 0.25% maximum and 22 HRc maximum hardness. CE= 0.43% maximum.

FULL OPENING THROUGH CONDUIT DESIGN: WALWORTH Expanding Gate valves allows the pipeline fluids to flow freely with a minimum of turbulence. In open position, obturator allows the running of pigs, scrapers, wipers or hot tap cutters through the pipeline with no danger or damage to the internal mechanical components of the valve. Full-flow design keeps line scrapers from becoming stuck into the valve's bore and prevents metal cuttings from jamming moving parts. Circular bore as per API-6D table 1.

EASY FIELD MAINTENANCE: Even with its sophistication, the **WALWORTH** Expanding Gate Valve can be completely overhauled without removal from the line. The seats of the valve can be removed, serviced and/or replaced with the valve installed.

ENERGIZED SEAT FOR POSITIVE SEALING: When the obturator is in the closed position, the seats (one on each side of the gate and segment) are energized to have a tight seal upstream and downstream. The valve seats have a nylon or RPTFE (Reinforced PolyTetraFluoroEthylyene) circular insert on their sealing faces. Two elastomer O-rings on the peripheral surfaces of the seats prevent the fluid passing through the seats when the valve is expanded due to pressure. In this way, the sealing action of the O-rings actually increases with fluid pressure. There are also metal to metal options upon request.

NO LUBRICATION NEEDED: The **WALWORTH** Expanding Gate Valve does not require lubrication for normal operation. However, if a sealing member becomes to be damage, a sealant can be injected into seat rings sealing areas waiting for future repairs.

PACKING CHAMBER: Chevron style packings installed to seal the packing chamber. A lantern ring with two secondary viton O'rings are also included around a lantern ring.

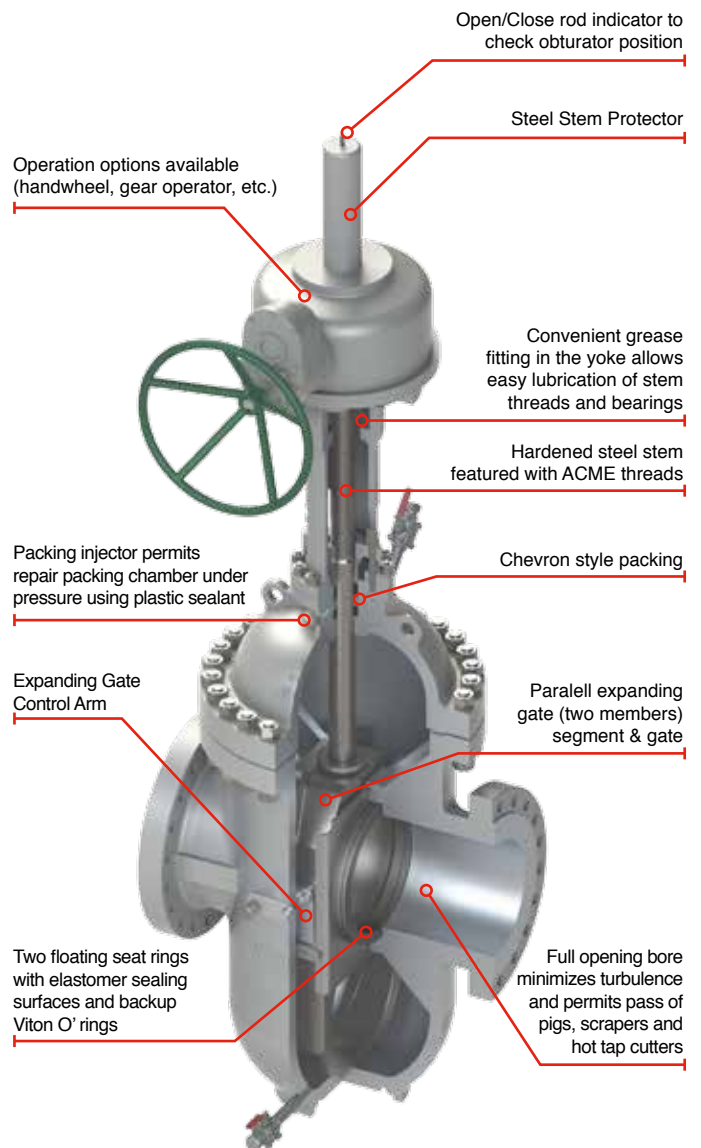

THROUGH CONDUIT RISING STEM DESIGN EXPANDING GATE VALVES

DISC CONFIGURATION

The disc is made with a gate (closure number) preferable installed on downstream side of the valve; and a segment which is in the upstream side as shown below. The stem is attached to the gate and the stem it forces acts also through the control arm to move segment. Both gate and segment are made from forged or cast steel and electroless nickel plated (ENP) 0.003" minimum thickness to prevent corrosion or galling. Hard faced seat areas of the gate and segment with welding overlays (stellite) or complete hard facing coating all over the disc such as tungsten carbide, chromium carbide, stellite, etc. using HVOF process in house are available upon request. This design also minimizes friction between closure members (gate & segment) against seats.

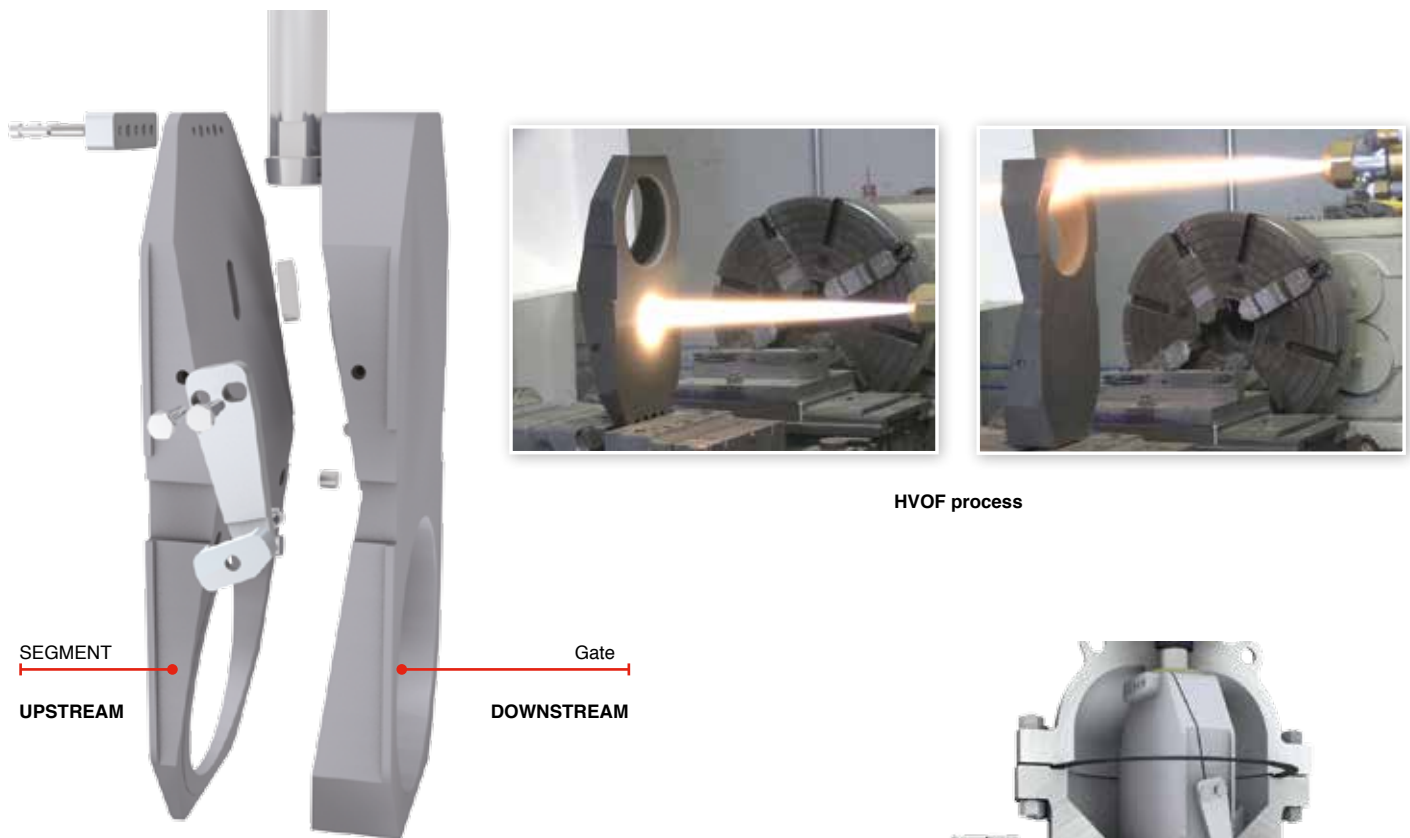

FULL OPENING THROUGH CONDUIT DESIGN

Valves are suitable for pigging operation.- Whenever a pipeline requires maintenance or inspection, the use of scrappers, pigs, wipers or gauges is necessary. WALWORTH Expanding Gate valves are through conduit design as have circular bore in the obturator (gate & segment) that allows these toolings to pass with a nominal size not less than specified in API-6D (Minimum bore for full opening valves).

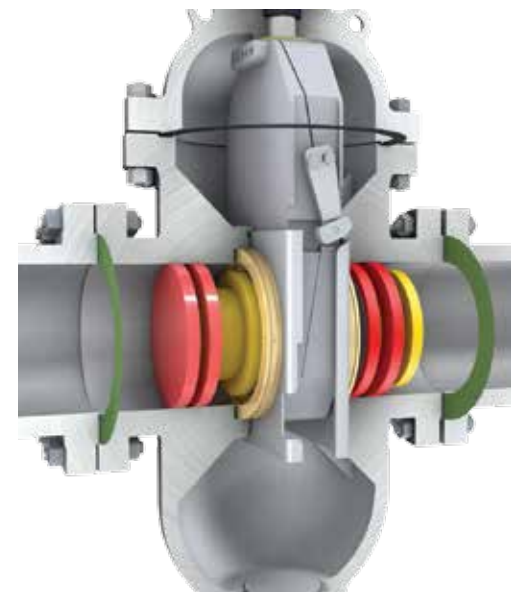

OPERATION DESIGN VALVE POSITIONS

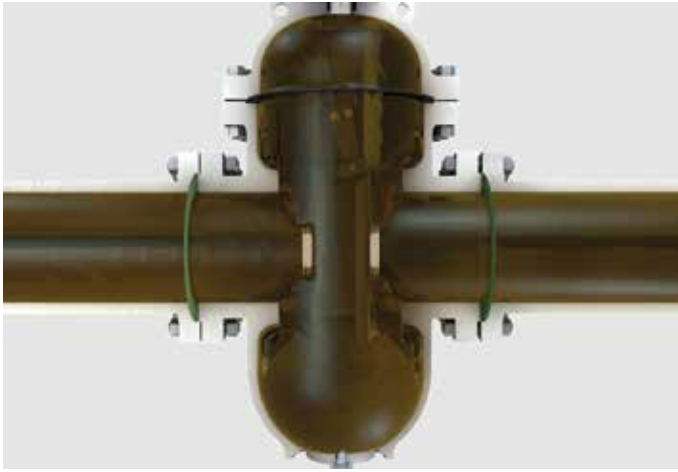

OPEN POSITION

To explain properly this operation design, let's define the two members of the Expanding Gate as gate (closure member) preferable installed on downstream at the right side and segment which is in the left side. When the valve is in the open position, the bottom angles of two members (gate and segment) are in contact.

During opening operation the stem forces the gate and the segment to come up, during the last stage of the travel, the segment makes contact with the bonnet stop and cannot move up anymore, then the gate keep rising, and due the forces related to the angle in between gate and segment, both components of the closure member expand outward, forcing them (gate and segment) against the seats.

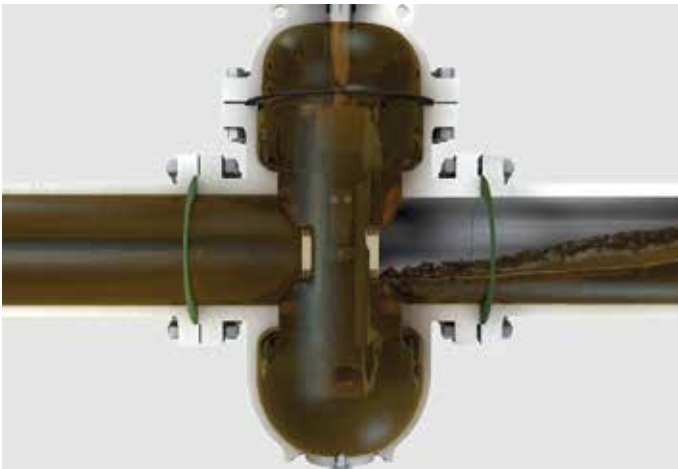

TRAVELLING POSITION

During opening or closing travel of the closure member (gate and segment), both of them are compressed themselves in the middle of the seats. In this compressed travelling position, their total width is less than the distance in between the valve seats avoiding friction in between the closure member (gate and segment) and the valve seats.

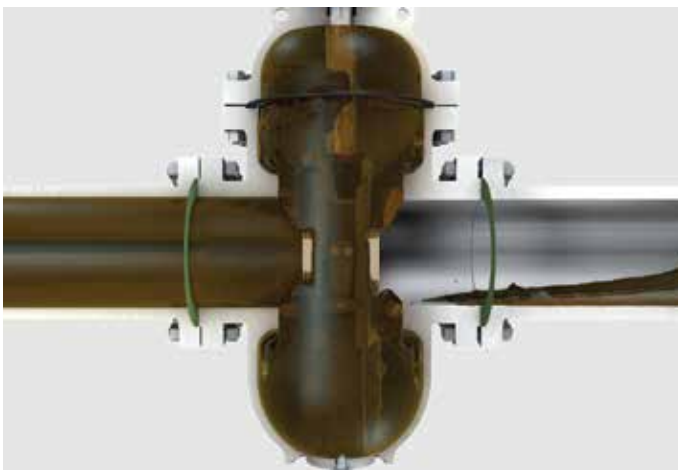

CLOSED POSITION

When the valve is in closed position, the top angles of the two members are in contact. The stem forces the gate and segment down; during the last stage of the travel, the segment contact with the body stop and cannot move down anymore, then the gate keeps going down and due the forces related to the angle in between gate and segment, both components expand outward, forcing them against the seats.

CONTROL ARM OPERATION

In figure 1 below, the valve is open. Note that segment is stopped by contact with the bonnet stop. The stem is attached to the gate and continues the travel up allowing it to have a lower angle than the segment, expanding both of them against the seats. In this position, the Control Arm swings to the right side through a gap in the gate guide rails which permits relative vertical movement in between gate and segment.

During the opening or closing travel as shown in figure 2, the Control Arm tends to swing to the left side, but is stopped at mid position by the left gate guide rail. This holds the gate and segment in the “nested” position where neither back angles act; therefore there is no forced contact in between closure member (gate and segment) against the seats which minimize friction during travel operation.

The figure 3 below shows the valve during closing operation. The segment going down is stopped by a lug on its upper end by contact with the body stop. At this point, there is a gap in the left -hand guide rail, then the Control Arm can swing to the left side and allow the gate continues moving down. The upper gate and segment back becomes in contact and expand both gate and segment against the seats.

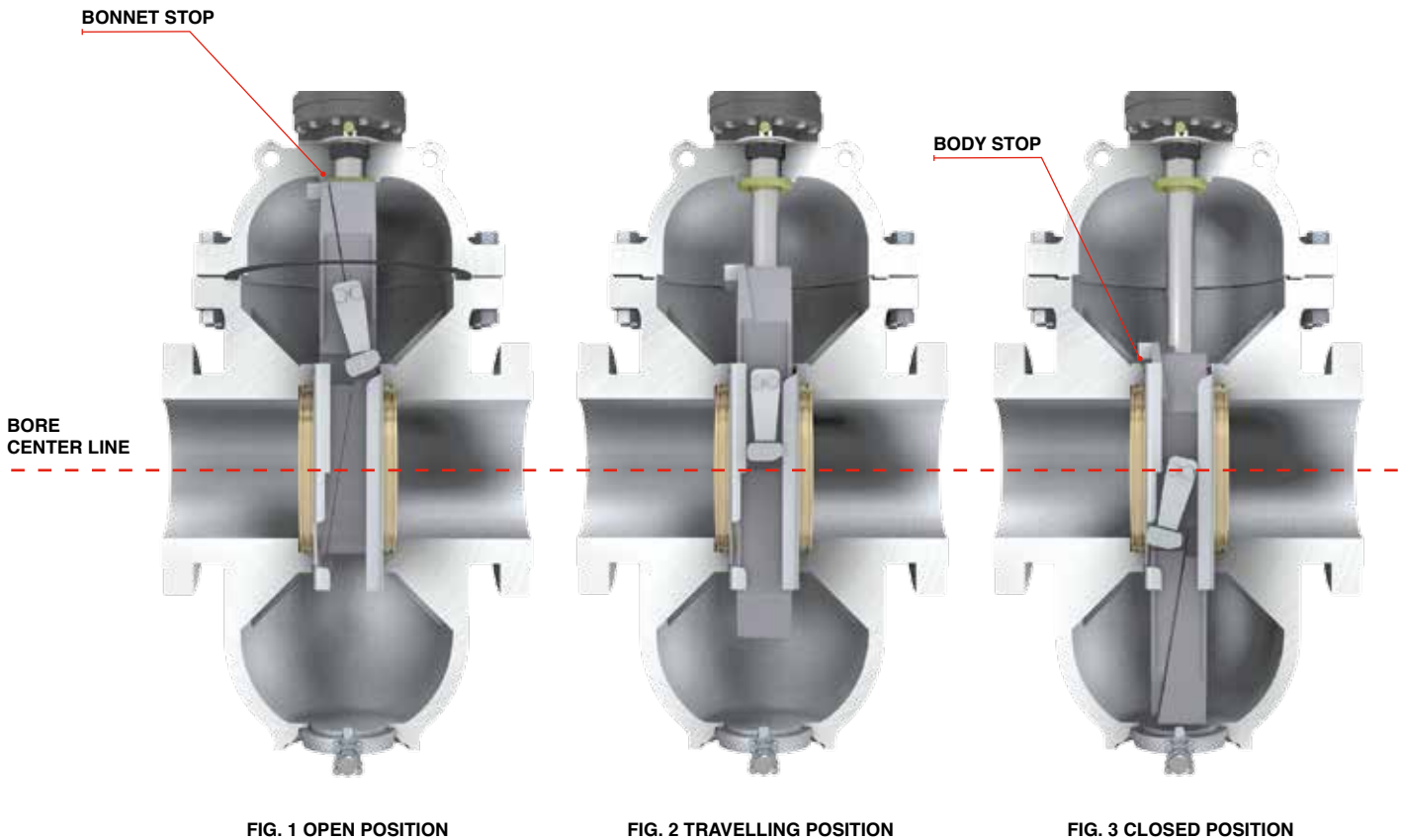

EXPANDING GATE VALVE DESIGN FEATURES

VENTING SYSTEMS ON BONNET

A feature is installed on bonnet to check if body-bonnet cavity retain pressure. A special vent plug is installed on top of the bonnet and allen screw is fitted inside this vent plug. In order to eliminate over pressure inside body-bonnet cavity unscrew lightly the allen screw until fluid come out through the lateral holes located aside the plug; this is a safety way to eliminate overpressure and avoid any injury to the personnel.



Upon request, relief ball check valve can be installed on bonnet instead the plug (venting system) to protect the valve in case of over pressure deriving this pressure to another pipeline.



EXPANDING GATE VALVE DESIGN FEATURES

SEAL SYSTEM ON PACKING CHAMBER

Packing chamber is provided with chevron style packing made from graphite. PTFE or other materials are available upon request. A lantern ring with two viton O’rings are also included as a secondary seal

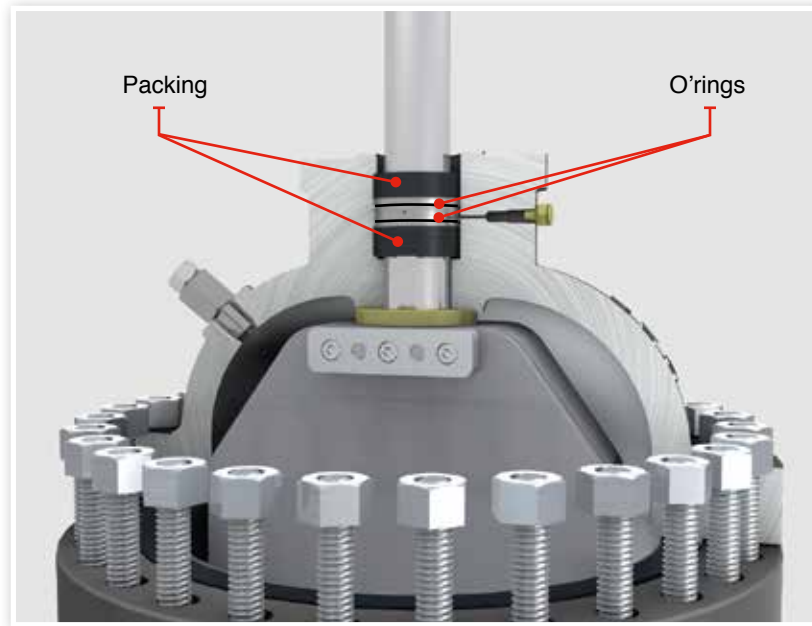

DRAIN OF THE VALVE

Due to the type of service of the Expanding Gate Valve, after a period of time the valve accumulates slurries in the bottom of the body where the obturator is allocated in closed position. To clean this area, the valve is provided with a plug for drain purposes. Floating ball valve can be installed instead a plug upon request.

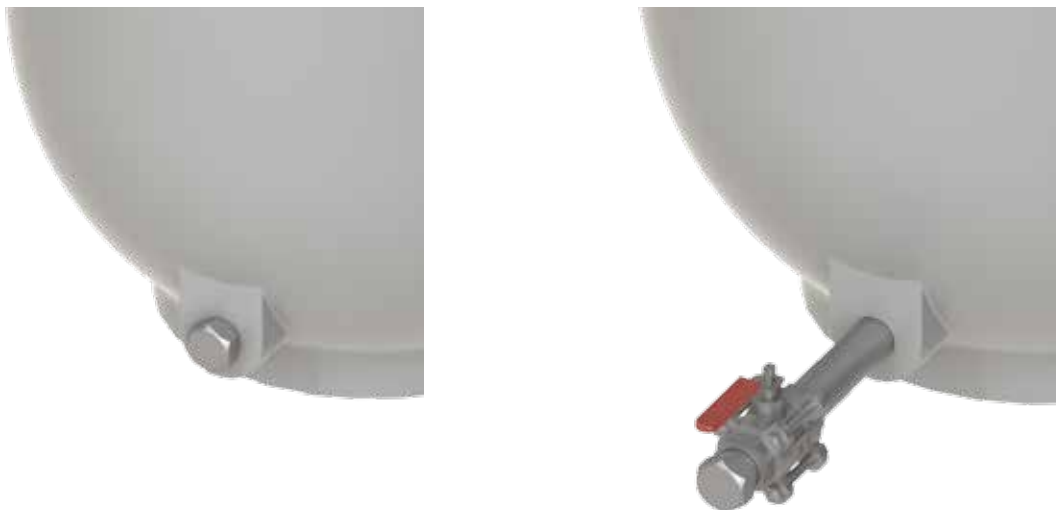

EXPANDING GATE VALVE DESIGN FEATURES

EMERGENCY SEALANT INJECTOR ON PACKING CHAMBER

If specified by the customer, packing chamber is also manufactured with emergency sealant injector in case of packing failure. When necessary it is possible to inject plastic sealant or PTFE through the lantern ring while the valve is under pressure to stop the leakage.

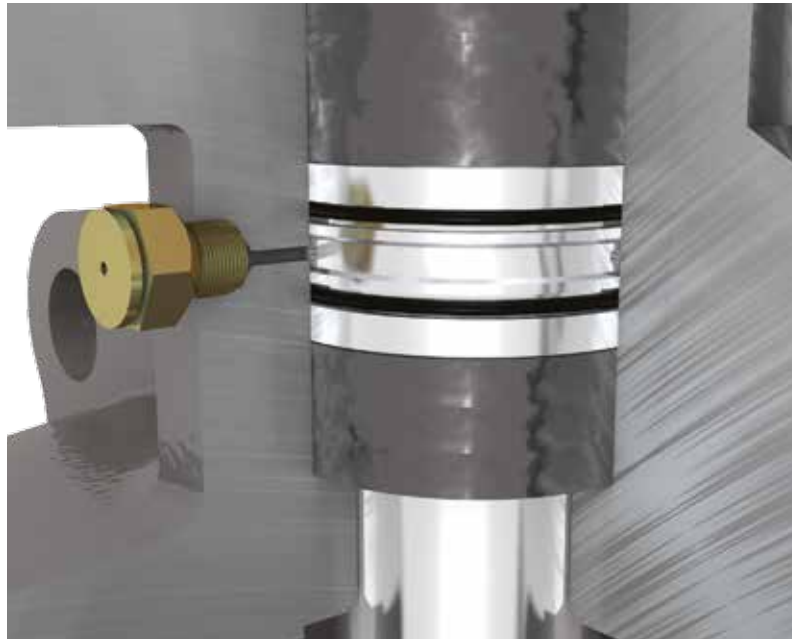

SEATS ARRANGEMENT

The seating arrangement is designed for positive sealing composed of ENP coated seat and soft inserts that ensure that primary sealing occurs at the gate. In case of soft seat damage, metal to metal seating will function as a secondary seal. Metal to metal seating design is available for abrasive service upon request.

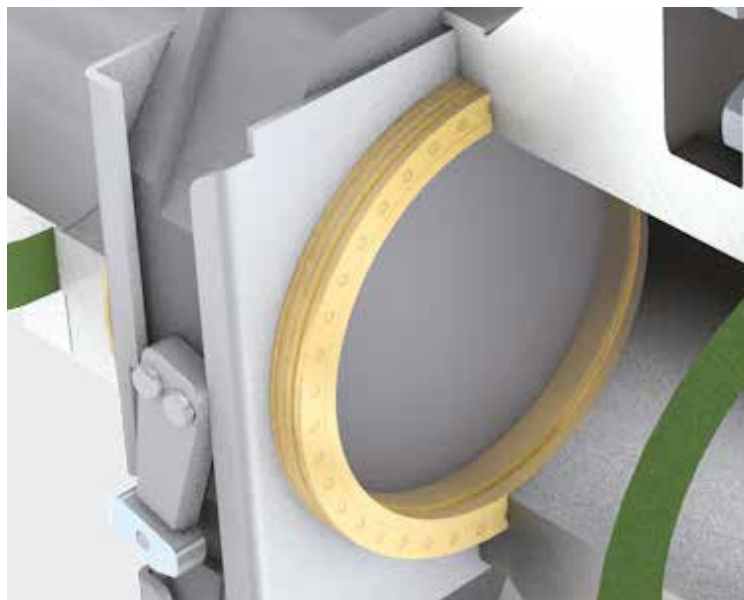

EXPANDING GATE VALVE DESIGN FEATURES

EMERGENCY SEALANT INJECTOR SYSTEM ON SEAT RINGS

In case of damage in service of the seat rings a secondary plastic sealant injection system is provided to seal all sealing surface of the seat rings. This is a temporary sealing fixture to help the valve sealing until can be repaired. These sealing fittings are located strategically to assure complete coverage of the sealing seats surfaces to permit fill all around the seats.

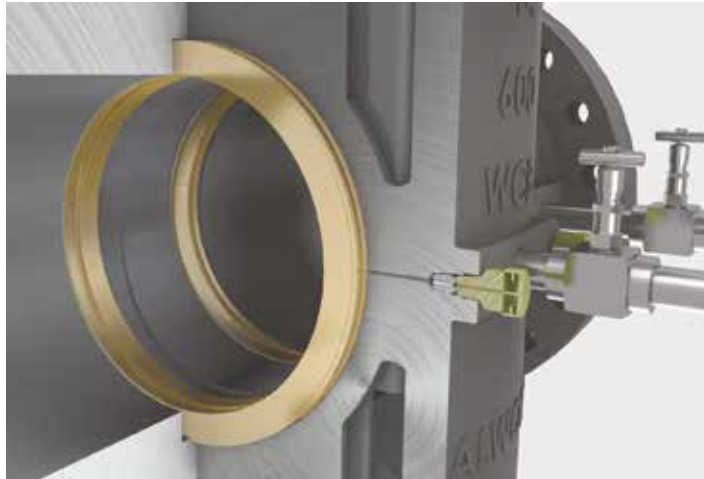

* Some valves for high temperature service does not have sealant injector system

BY-PASS

Walworth valves may entrap over pressure in the central cavity as a consequence of thermal expansion on liquid service. To avoid this over pressure the valve is supplied with a relief system as shown in the next figure.



Special by-pass systems can be supplied upon request.

EXPANDING GATE VALVE DESIGN FEATURES

DOUBLE BLOCK & BLEED DESIGN (DBB)

Expanding Gate Valve can be subject to maintenance or repair on line without remove it from the line. When pressure is acting on both sides of the valve (upstream & downstream) seat rings design activates them against the disc to keep the valve sealing. Once the valve is acting as “DBB”, pressure and/or fluid on body-bonnet cavity can be released through the body drain system.

To test this feature with the valve half-open, the valve and its cavity shall be completely filled with test fluid. The valve shall then be closed and the valve body vent valve opened to allow excess test fluid to overflow from the valve cavity test connection. The pressure test shall be applied simultaneously from both valve ends. Seat tightness shall be monitored through the valve cavity connection.

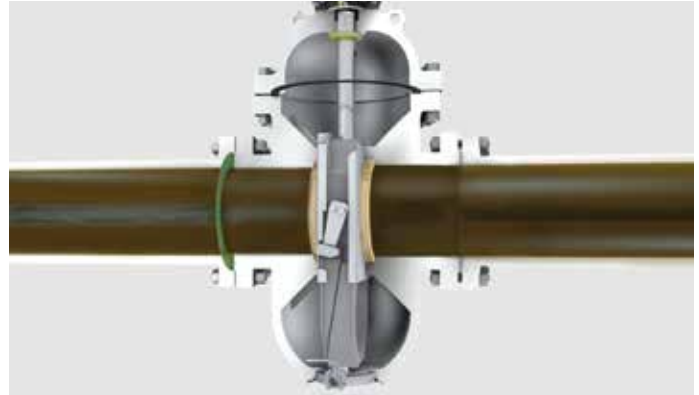

BIDIRECTIONAL SEATS

WALWORTH Expanding Gate Valves are bidirectional; this means that are designed for blocking the fluid in both upstream and downstream directions because bidirectional seats offer double piston effect.

To test this feature with the valve half-open, the valve and its cavity shall be completely filled with test fluid. The valve shall be then closed and the test pressure applied successively to both ends of the valve. Seat leakage shall be monitored from each seat via the valve body cavity vent or drain connection, where provided. If there is not drain connections, seat leakage shall be monitored from the respective downstream end of the valve.

DOUBLE ISOLATION AND BLEED DIB-1 (Both seats bi-directional)

Each seat shall be tested in both directions.

Cavity-relief valves shall be removed if fitted. The valve and cavity shall be filled with test fluid, with the valve half-open, until test fluid overflows through the cavity relief connection.

To test for seat leakage in the direction of the cavity, the valve shall be closed. The test pressure shall be applied successively to each valve end to test each seat separately from the upstream side. Leakage shall be monitored via the valve cavity pressure relief connection.

Thereafter, each seat shall be tested as downstream seat. Both ends of the valve shall be drained and the valve cavity filled with test fluid. Pressure shall then be applied while monitoring leakage through each seat at both ends of the valve. Some valve designs can require the balancing of the upstream and valve cavity pressure during the downstream seat test.

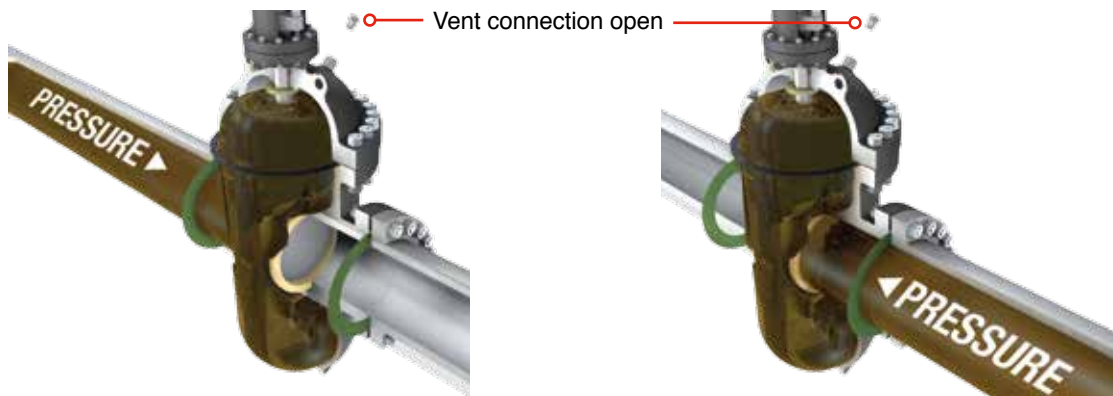

FINITE ELEMENT ANALYSIS AND COMPUTER-ASSISTED DESIGN

FINITE ELEMENT ANALYSIS

WALWORTH makes extensive use of the latest state-of-the-art Finite Element Analysis techniques to optimize their valve designs. Through this approach, the performance of a complex structure, such as a valve, can be predicted by reducing it to a grouping of finite number of smaller structural elements more readily subjected to mathematical modeling.

All critical components of the valve are thoroughly analyzed by this technique to assure the structural, as well as functional integrity of the valve.

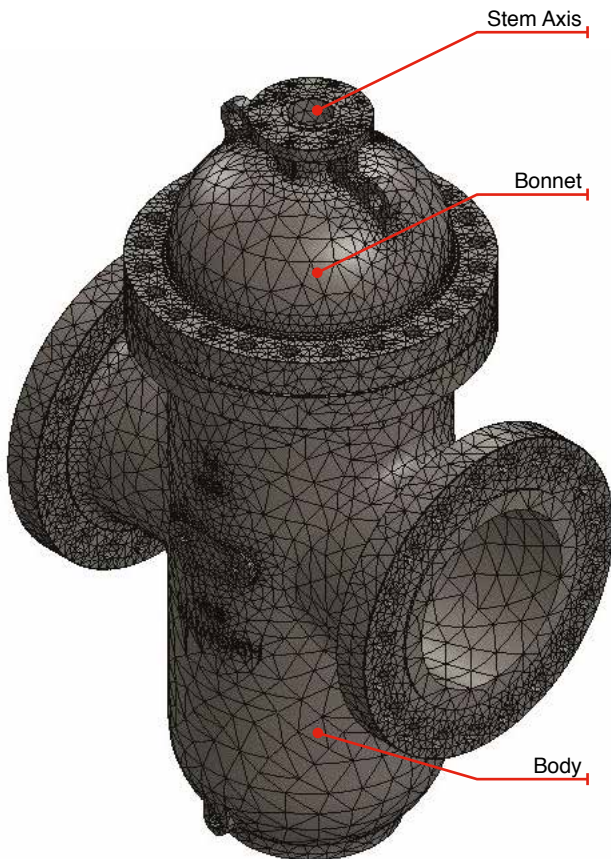

FINITE ELEMENT MODEL OF GATE VALVE

PIPING LOADS CONSIDERED

In actual service, sometimes very high pipe loads may be transmitted to the valve ends by the attached pipeline system. The adequacy of the WALWORTH valves under these loads is established by thorough analysis in which pressure, pipe imposed bending moments and axial loads are considered simultaneously.

Stresses, as well as deflections, are analyzed to assure that the valve will continue to perform satisfactorily under the severe combination of these loads.



BODY CENTER SECTION
UNDER APPLIED BENDING MOMENT.

FINITE ELEMENT ANALYSIS AND COMPUTER-ASSISTED DESIGN

OPTIMIZATION BY PARAMETRIC STUDIES AND COMPUTER-AIDED-DESIGN APPROACH

In optimizing the valve designs, detailed parametric studies involving many non-dimensional parameters are conducted on the critical components of the valve.

These studies have helped us develop optimum valve results of these Finite Elements Analysis and Parametric Studies are incorporated in a Computer Program that produces the complete design information for a valve of any given pressure rating most efficiently.



FINITE ELEMENT MESH USED IN OPTIMIZATION STUDIES

VALIDATION BY TESTING

Finite Element predications are validated by conducting actual non-destructive and performance tests on valves. It is integrated Finite Element Analysis, Computer- Assisted-Design and Testing Approach that assures that WALWORTH valves are technically most suitable, yet one of the most economical available valves for the application.

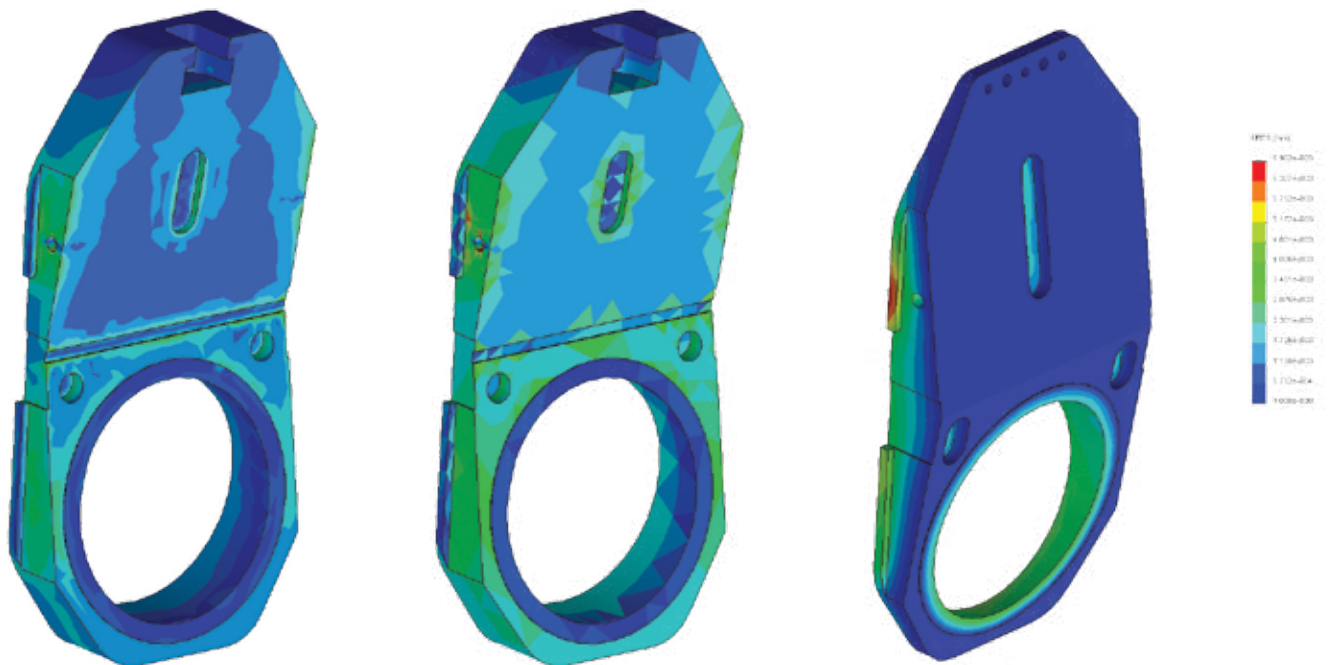

DETAILED STRESS CONTOURS

SOFT SEAT-METAL SEAT EXPANDING GATE VALVE

Regular Bill of Materials		
No.	Description	Material
1	Stem Protector	Carbon Steel A106
2	Rod indicator	ASTM A108 Grade 1020
3	Handwheel	ASTM A 65-45-12
4	Gear Operator*	Commercial
5	Cover plate	ASTM A515 Grade 70
6	Thrust Bearings (not shown)	Commercial
7	Stem Nut** (not shown)	ASTM A439 Grade D2 or plate
8	Stem Sleeve	ASTM A216 Grade WCB
9	Stem	AISI 4140+ENP (0.003")
10	Packing Flange	ASTM A515 Grade 70
11	Packing Flange Bolts	ASTM A193 Grade B7
12	Packing Flange Nuts	ASTM A194 Grade 2H
13	Bonnet Stem Bushing	ASTM A276 Grade 410
14	Stem Packing	Graphite Chevron Style
15	Lantern Bushing	AISI 1020
16	Bonnet Stop	ASTM A515 Grade 70 or ASTM A105
17	Stem Sleeve Studs	ASTM A193 Grade B7
18	Stem Sleeve Nuts	ASTM A194 Grade 2H
19	Relief Valve	Carbon Steel Nickel Platted
20	Packing Injector	ASTM A316
21	Bonnet	ASTM A216 Grade WCB
22	Gasket	Graphite
23	Cap Screws	Commercial
24	Body Stop Lug	ASTM A515 Grade 70 or ASTM A 105
25	Segment	ASTM A515 Grade 70 or ASTM 105+ENP
26	Gate	ASTM A515 Grade 70 or ASTM 105+ENP
27	Control Arm	ASTM A515 Grade 70
28	Control Arm Screw	AISI 1045
29	Seat Rings	ASTM A515 Grade 70 or ASTM A105
30	Guide rails	ASTM A36
31	Bonnet Studs***	ASTM A193 Grade B7
32	Bonnet Nuts***	ASTM A194 Grade 2H
33	Body	ASTM A216 Grade WCB
34	Drain Plug	ASTM A105
35	Stem Sleeve Cap Screw	Commercial

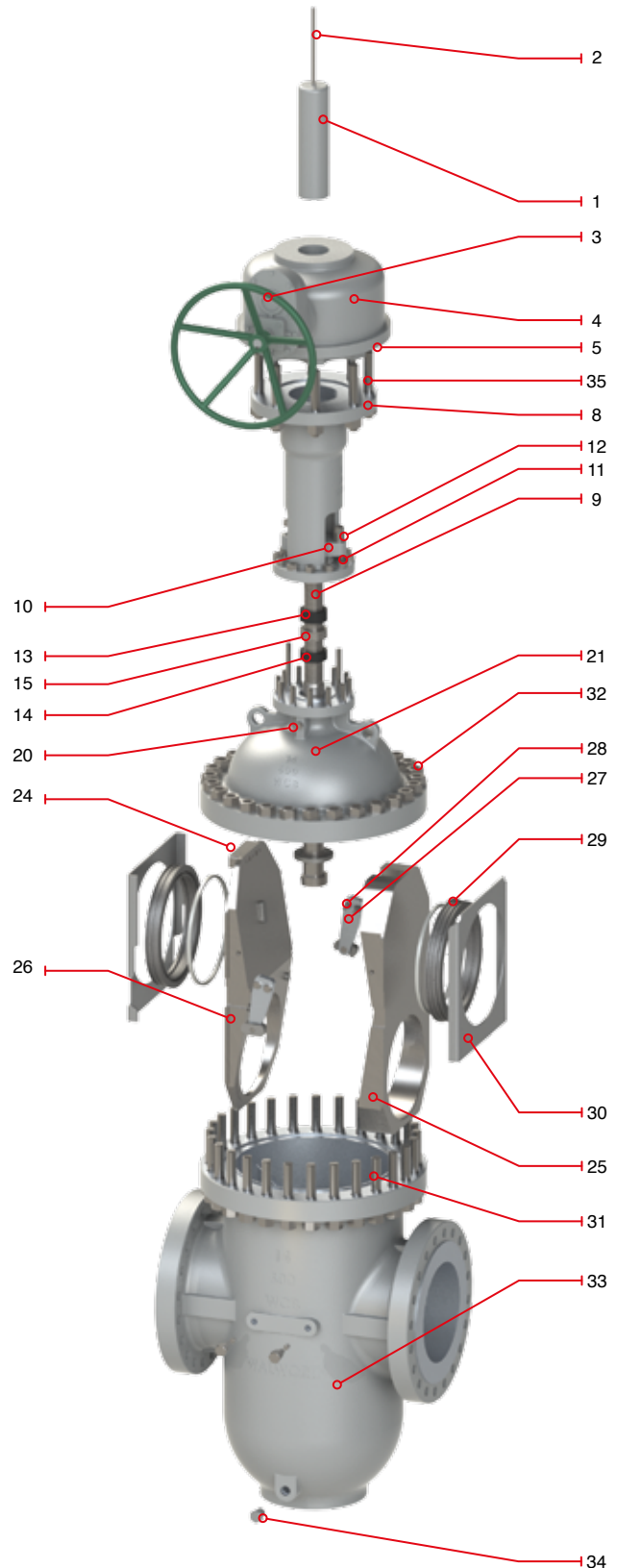

* Handwheel Operator as standard; gear operation as per customer request.

** For handwheel operation Ni-resist grade D2; for Gear Operation ASTM A515 grade 70.

*** For NACE Service Bolting/Nuts to be B7M/2HM.

**** For 8" and up back up springs on seat rings are provided (not shown).

METAL TO METAL SEAT EXPANDING GATE VALVE

Regular Bill of Materials		
No.	Description	Material
1	Stem Protector	Carbon Steel A106
2	Rod indicator	ASTM A108 Grade 1020
3	Handwheel	ASTM A 65-45-12
4	Gear Operator*	Commercial
5	Cover plate	ASTM A515 Grade 70
6	Thrust Bearings (not shown)	Commercial
7	Stem Nut** (not shown)	ASTM A439 Grade D2 or plate
8	Stem Sleeve	ASTM A216 Grade WCB
9	Stem	17-4pH or A276 Grade 410
10	Packing Flange	ASTM A515 Grade 70
11	Packing Flange Bolts	ASTM A193 Grade B7
12	Packing Flange Nuts	ASTM A194 Grade 2H
13	Bonnet Stem Bushing	ASTM A276 Grade 410
14	Stem Packing	Graphite Chevron Style
15	Lantern Bushing	AISI 1020
16	Bonnet Stop	ASTM A515 Grade 70 or ASTM A105
17	Stem Sleeve Studs	ASTM A193 Grade B7
18	Stem Sleeve Nuts	ASTM A194 Grade 2H
19	Relief Valve	Carbon Steel Nickel Platted
20	Packing Injector	AISI SS-316
21	Bonnet	ASTM A216 Grade WCB
22	Gasket	Graphite
23	Cap Screws	Commercial
24	Body Stop Lug	ASTM A515 Grade 70 or ASTM A 105
25	Segment****	ASTM A105 + ENP (030") + Special Coat
26	Gate****	ASTM A105 + ENP (030") + Special Coat
27	Control Arm	ASTM A515 Grade 70
28	Control Arm Screw	AISI 1045
29	Seat Rings	ASTM A105 + ENP (030") + Special Coat
30	Guide rails	ASTM A36
31	Bonnet Studs***	ASTM A193 Grade B7
32	Bonnet Nuts***	ASTM A194 Grade 2H
33	Body	ASTM A216 Grade WCB
34	Drain Plug	ASTM A105
35	Stem Sleeve Cap Screw	Commercial

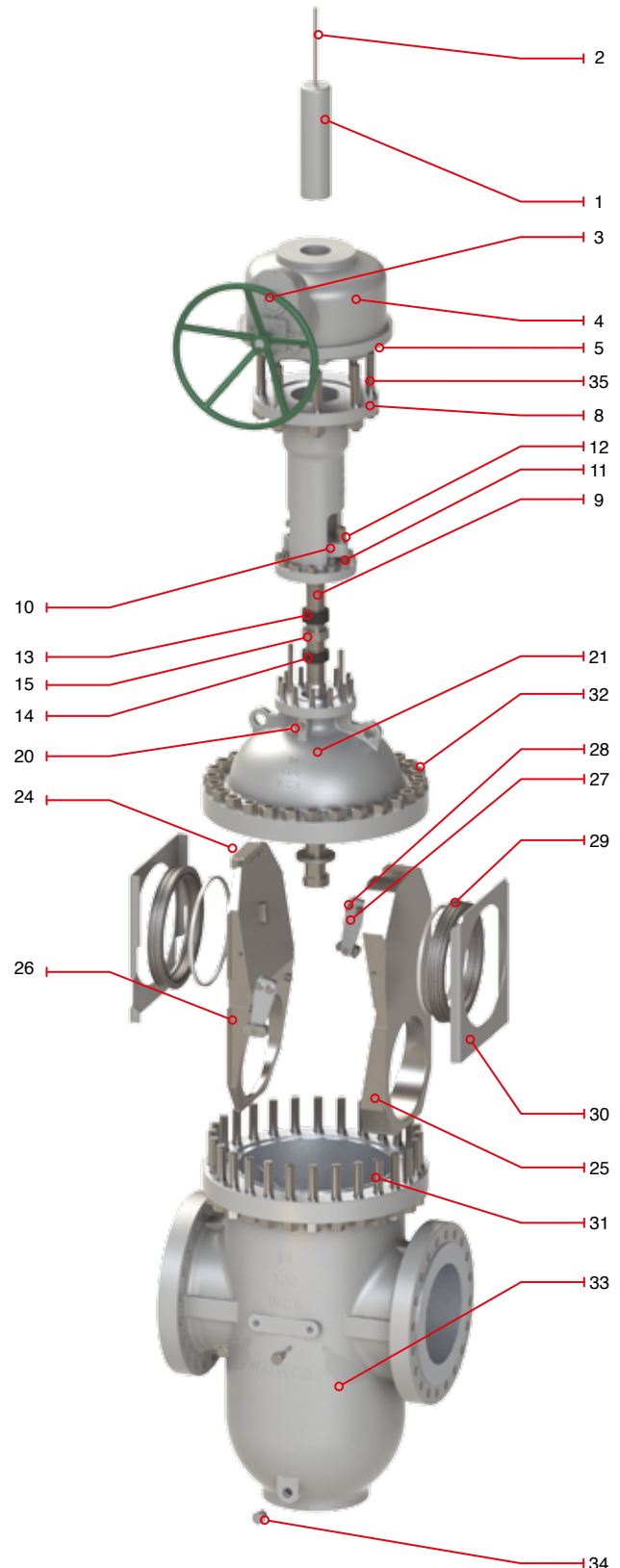

* Handwheel Operator as standard; gear operation as per customer request.
 **For handwheel operation Ni-Resist.grade D2/; for Gear Operation ASTM A515 grade 70.
 *** For NACE service Bolting / Nuts to be B7M / 2HM.
 **** Either tungsten carbide HFOV or Stellite Sealing areas.
 ***** For 8" and up back up springs on seat rings are provided (not shown).
 Note: Other special coatings as chromium carbide can be supplied upon request.

EXPANDING GATE VALVE CLASS 150

WALWORTH offers this product line in the following base materials:

- a) Carbon steel as per ASTM A216 grades WCB, WCC.
- b) Carbon steel for NACE applications as per ASTM A216 grade WCB with 0.25% maximum and 22 HRc maximum hardness. CE= 0.43% maximum.

DESIGN FEATURES

- c) Design in accordance with API-6D.
- d) Double block & bleed (DDB). In closed position, the valve is capable to block both seat ports; the fluid can be released through the drain plug located in the middle of the seal sealing surfaces as per MMS-SP-61 specification.
- e) With double isolation & vent system (DIB) the valve block both ports. Then internal pressure can be released using the pressure relief valve located on the bonnet.
- f) Designed for positive sealing with Expanding Gate.
- g) Expanding gate design minimizes friction between closure members (gate and segment) against seats.
- h) Full through conduit port and full opening to permit pass of scrappers, pigs and wipers.
- i) Secondary reinforced viton O'rings to provide corrosion-resistance seal.
- j) Top entry, studded bonnet and replaceable seats for easy maintenance even in line.
- k) This valve complies with API-6D technical requirements for double isolation and bleed.
- l) 100% interchangeability of parts.
- m) Non lubricated.
- n) Bi-direccional seats offer double piston effect.
- o) Multi-position installation.
- p) Rising stem.
- q) Handwheel, chainwheel, gear operation, electric, pneumatic or hydraulic actuation is available as per Customer requirements.
- r) Hard faced options are available for severe service with Tungsten carbide, Chromium carbide applied by HVOF. Stellite coating also available upon request.
- s) Test in accordance with API-6D.
- t) Availability on raised face, butt weld or ring type joint ends.
- u) Valves from 8" nominal diameter and over are supplied with lifting lugs.

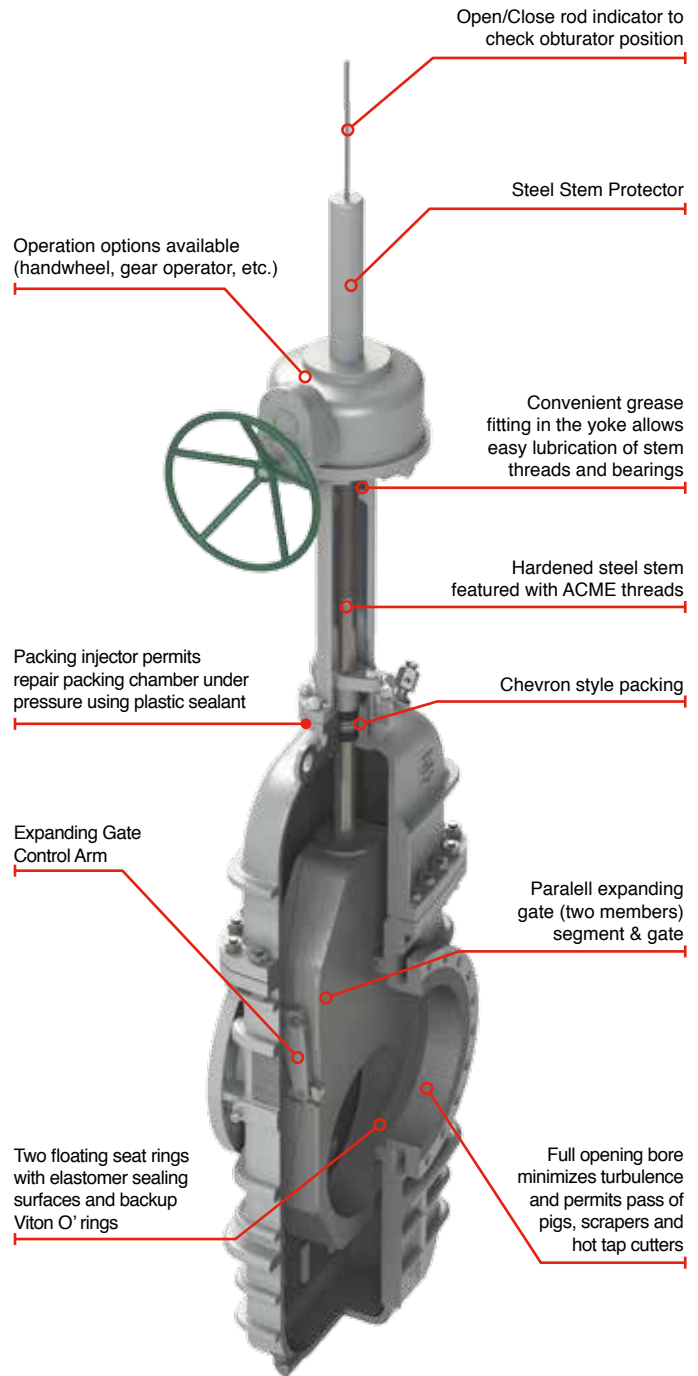

EXPANDING GATE VALVE ASME PRESSURE CLASS 150 (HANDWHEEL OPERATED)

DESIGN FEATURES

- Design in accordance with API-6D.
- Rising stem.
- Flanged dimensions as per ASME B16.5.
- For valves 26" and larger, flange dimensions as per ASME B16.47 Series A.
- End to end dimensions as per API-6D table 2 figure 1 (Valves not listed in this table as per ASME B16.10).
- WE dimensions as per ASME B31.4 and/or ASME B31.8 and tapered as per ASME B16.25 figure 1.
- Full opening through conduit.
- Sizes from 2" to 8" handwheel operated as standard.

FIGURE No.	OPERATION	TYPE OF ENDS
1DE12	Handwheel	RF
1DE13	Handwheel	RTJ
1DE14	Handwheel	WE

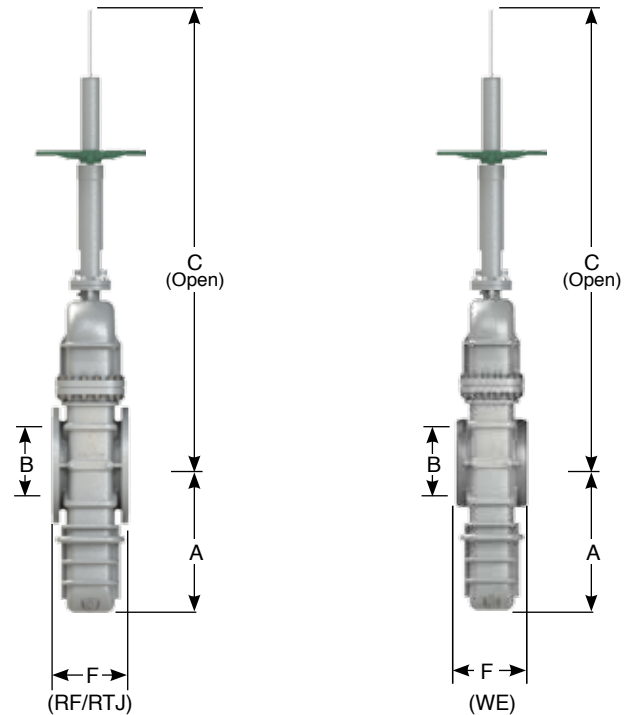

DIMENSIONS AND WEIGHTS

NOMINAL DIAMETER	mm	50	80	100	150	200
	in	2	3	4	6	8
A	mm	152	195	237	340	435
	in	5.98	7.68	9.33	13.39	17.13
B	mm	49	74	100	150	201
	in	1.93	2.91	3.94	5.91	7.91
C (Open)	mm	662	782	895	1239	1395
	in	26.08	30.81	35.26	48.81	54.96
F (RF)	mm	178	203	229	267	292
	in	7.013	7.99	9.02	10.51	11.5
F (RTJ)	mm	191	216	241	279	305
	in	7.52	8.51	9.49	10.99	12.01
F (WE)	mm	216	283	305	403	419
	in	8.51	11.15	12.01	15.87	16.5
WEIGHT	kg	46	76	114	193	320
	lb	101	167	251	425	705

Flanged Dimensions as per ASME/ANSI B16.34, B16.5 & B16.47

EXPANDING GATE VALVE ASME PRESSURE CLASS 150 (GEAR OPERATED)

DESIGN FEATURES

- a) Design in accordance with API-6D.
- b) Rising stem.
- c) Flanged dimensions as per ASME B16.5.
- d) For valves 26" and larger, flange dimensions as per ASME B16.47 Series A.
- e) End to end dimensions as per API-6D table 2 figure 1 (Valves not listed in this table as per ASME B16.10).
- f) WE dimensions as per ASME B31.4 and/or ASME B31.8 and tapered as per ASME B16.25 figure 1.
- g) Full opening through conduit.
- h) Sizes from 10" to 48" Gear operator as standard.

FIGURE No.	OPERATION	TYPE OF ENDS
1DE22	Gear Operated	RF
1DE23	Gear Operated	RTJ
1DE24	Gear Operated	WE

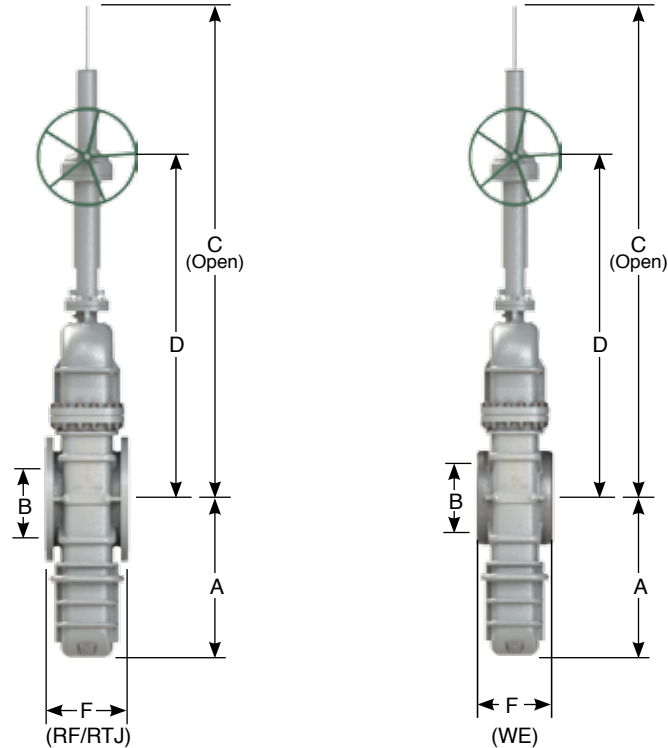

DIMENSIONS AND WEIGHTS

NOMINAL DIAMETER	mm	250	300	350	400	450	500	600	650	700
	in	10	12	14	16	18	20	24	26	28
A	mm	525	610	635	722	808	950	1130	1205	1255
	in	20.68	24.03	25.01	28.44	31.83	37.43	44.52	47.47	49.44
B	mm	252	303	334	385	436	487	589	633	684
	in	9.92	11.93	13.15	15.16	17.17	19.18	23.2	24.94	26.94
C (Open)	mm	1730	2001	2240	2430	2660	3082	3530	3803	3988
	in	68.16	78.83	88.25	95.74	104.8	121.43	139.08	149.83	157.12
D	mm	1067	1220	1392	1500	1646	1916	2145	2296	2355
	in	42.03	48.06	54.84	59.1	64.85	75.49	84.51	90.46	92.78
F (RF)	mm	330	356	381	406	432	457	508	559	610
	in	13	14.02	15.01	15.99	17.02	18	20.01	22.02	24.03
F (RTJ)	mm	343	368	394	419	445	470	521	-	-
	in	13.51	14.49	15.52	16.5	17.53	18.51	20.52	-	-
F (WE)	mm	457	502	572	610	660	711	813	864	914
	in	18	19.77	22.53	24.03	26	28.01	32.03	34.04	36.01
WEIGHT	kg	480	615	815	1000	1210	1520	2730	3150	3600
	lb	1058	1355	1796	2204	2667	3350	6018	6944	7936

Flanged Dimensions as per ASME/ANSI B16.34, B16.5 & B16.47

EXPANDING GATE VALVE ASME PRESSURE CLASS 150 (GEAR OPERATED)

DESIGN FEATURES

- Design in accordance with API-6D.
- Rising stem.
- Flanged dimensions as per ASME B16.5.
- For valves 26" and larger, flange dimensions as per ASME B16.47 Series A.
- End to end dimensions as per API-6D table 2 figure 1 (Valves not listed in this table as per ASME B16.10).
- WE dimensions as per ASME B31.4 and/or ASME B31.8 and tapered as per ASME B16.25 figure 1.
- Full opening through conduit.
- Sizes from 10" to 48" Gear operator as standard.

FIGURE No.	OPERATION	TYPE OF ENDS
1DE22	Gear Operated	RF
1DE23	Gear Operated	RTJ
1DE24	Gear Operated	WE

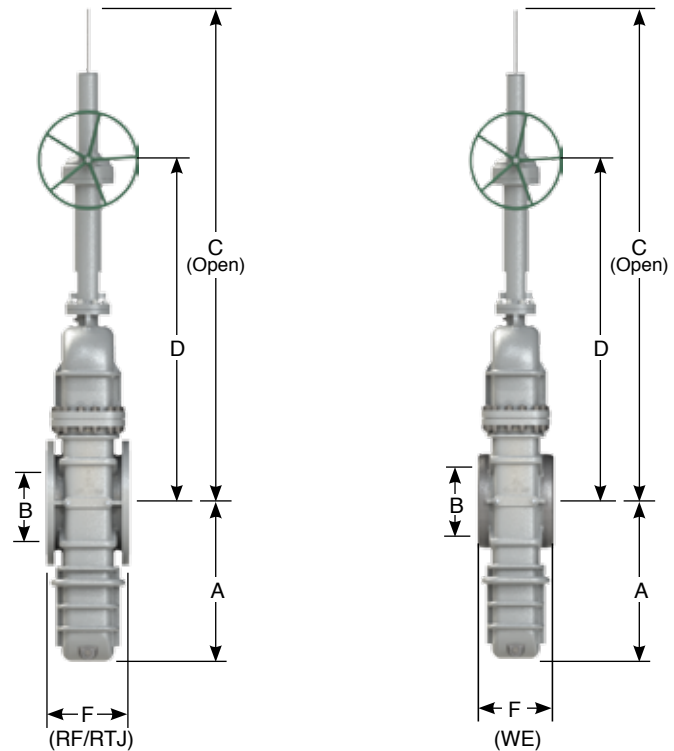

DIMENSIONS AND WEIGHTS

NOMINAL DIAMETER	mm	750	800	850	900	950	1000	1050	1200
	in	30	32	34	36	38	40	42	48
A	mm	1330	1400	1480	1540	1720	1795	1970	2120
	in	52.4	55.16	58.31	60.67	67.76	70.72	77.61	83.52
B	mm	735	779	830	874	925	976	1020	1166
	in	28.95	30.69	32.7	34.43	36.44	38.45	40.18	45.94
C (Open)	mm	4276	4521	4798	5070	5252	5614	5926	6478
	in	168.47	178.12	189.04	199.75	206.92	221.19	233.48	255.23
D	mm	2532	2706	2872	3044	3129	3393	3577	3828
	in	99.76	106.61	113.15	119.93	123.28	133.68	140.93	150.82
F (RF)	mm	660	711	762	813	864	914	965	1118
	in	26	28.01	30.02	32.03	34.04	36.01	38.02	44.04
F (RTJ)	mm	-	-	-	-	-	-	-	-
	in	-	-	-	-	-	-	-	-
F (WE)	mm	914	965	1016	1016	1067	1118	1168	1321
	in	36.01	38.02	40.03	40.03	42.03	44.04	46.01	52.04
WEIGHT	kg	3800	4860	5820	7300	8400	9260	10150	14220
	lb	8377	10714	12830	16093	18518	20414	22376	31349

Flanged Dimensions as per ASME/ANSI B16.34, B16.5 & B16.47

EXPANDING GATE VALVE CLASS 300

WALWORTH offers this product line in the following base materials.

- a) Carbon steel as per ASTM A216 grades WCB, WCC.
- b) Carbon steel for NACE applications as per ASTM A216 grade WCB with 0.25% maximum and 22 HRc maximum hardness. CE= 0.43% maximum.

DESIGN FEATURES

- c) Design in accordance with API-6D.
- d) Double block & bleed (DDB). In closed position, the valve is capable to block both seat ports; the fluid can be released through the drain plug located in the middle of the seal sealing surfaces as per MMS-SP-61 specification.
- e) With double isolation & vent system (DIB) the valve block both ports. Then internal pressure can be released using the pressure relief valve located on the bonnet.
- f) Designed for positive sealing with Expanding Gate.
- g) Expanding gate design minimizes friction between closure members (gate and segment) against seats.
- h) Full through conduit port and full opening to permit pass of scrappers, pigs and wipers.
- i) Secondary reinforced viton O'rings to provide corrosion-resistance seal.
- j) Top entry, studded bonnet and replaceable seats for easy maintenance even in line.
- k) This valve complies with API-6D technical requirements for double isolation and bleed.
- l) 100% interchangeability of parts.
- m) Non lubricated.
- n) Bi-direccional seats offer double piston effect.
- o) Multi-position installation.
- p) Rising stem.
- q) Handwheel, chainwheel, gear operation, electric, pneumatic or hydraulic actuation is available as per Customer requirements.
- r) Hard faced options are available for severe service with Tungsten carbide, Chromium carbide applied by HVOF. Stellite coating also available upon request.
- s) Test in accordance with API-6D.
- t) Availability on raised face, butt weld or ring type joint ends.
- u) Valves from 8" nominal diameter and over are supplied with lifting lugs.

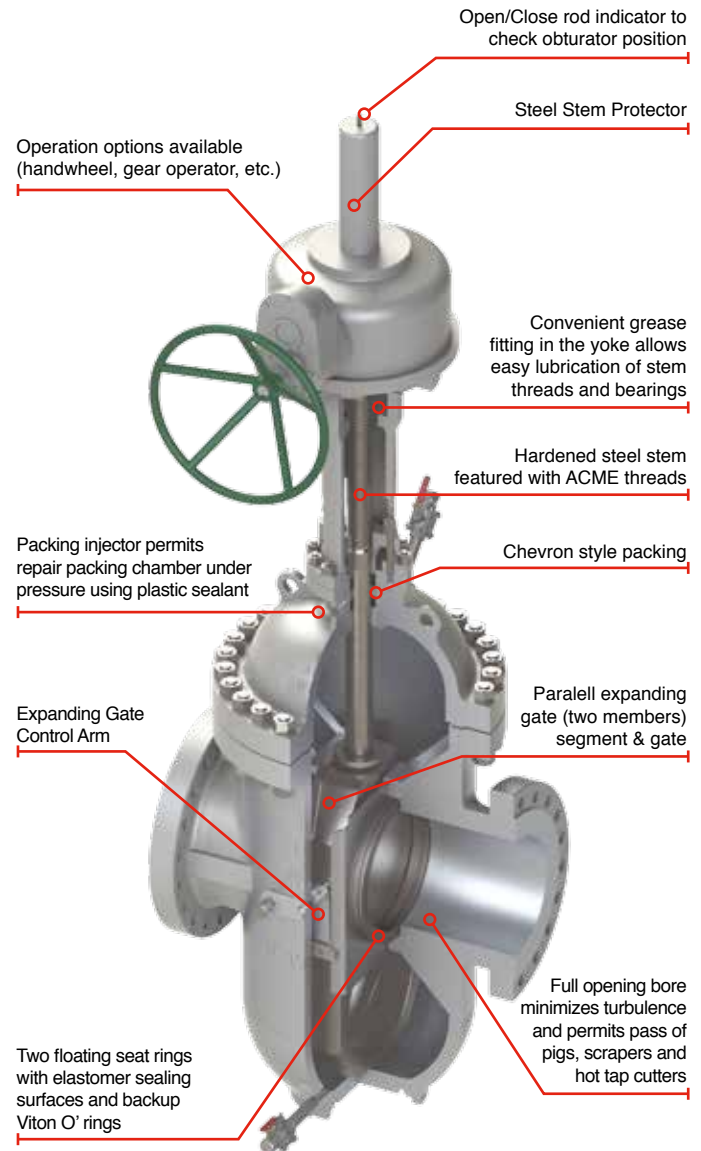

EXPANDING GATE VALVE ASME PRESSURE CLASS 300 (HANDWHEEL OPERATED)

DESIGN FEATURES

- Design in accordance with API-6D.
- Rising stem.
- Flanged dimensions as per ASME B16.5.
- For valves 26" and larger, flange dimensions as per ASME B16.47 Series A.
- End to end dimensions as per API-6D table 2 figure 1 (Valves not listed in this table as per ASME B16.10).
- WE dimensions as per ASME B31.4 and/or ASME B31.8 and tapered as per ASME B16.25 figure 1.
- Full opening through conduit.
- Sizes from 2" to 8" handwheel operated as standard.

FIGURE No.	OPERATION	TYPE OF ENDS
3DE12	Handwheel	RF
3DE13	Handwheel	RTJ
3DE14	Handwheel	WE

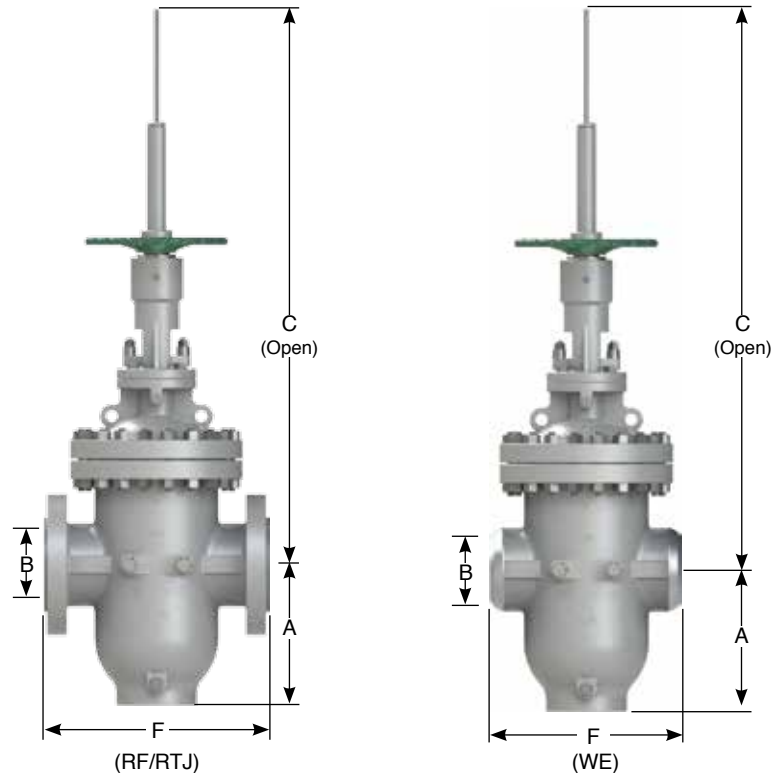

DIMENSIONS AND WEIGHTS

NOMINAL DIAMETER	mm	50	80	100	150	200
	in	2	3	4	6	8
A	mm	152	195	237	340	435
	in	5.98	7.68	9.33	13.39	17.13
B	mm	49	74	100	150	201
	in	1.93	2.91	3.94	5.91	7.91
C (Open)	mm	662	782	895	1239	1395
	in	26.06	30.79	35.24	48.78	54.92
F (RF)	mm	216	283	305	403	419
	in	8.51	11.15	12.01	15.87	16.5
F (RTJ)	mm	232	298	321	419	435
	in	9.14	11.74	12.64	16.5	17.13
F (WE)	mm	216	283	305	403	419
	in	8.51	11.15	12.01	15.87	16.5
WEIGHT	kg	73	115	155	330	500
	lb	161	253	341	727	1102

Flanged Dimensions as per ASME/ANSI B16.34, B16.5 & B16.47

EXPANDING GATE VALVE ASME PRESSURE CLASS 300 (GEAR OPERATED)

DESIGN FEATURES

- a) Design in accordance with API-6D.
- b) Rising stem.
- c) Flanged dimensions as per ASME B16.5.
- d) For valves 26" and larger, flange dimensions as per ASME B16.47 Series A.
- e) End to end dimensions as per API-6D table 2 figure 1 (Valves not listed in this table as per ASME B16.10).
- f) WE dimensions as per ASME B31.4 and/or ASME B31.8 and tapered as per ASME B16.25 figure 1.
- g) Full opening through conduit.
- h) Sizes from 10" to 48" gear operator as standard.

FIGURE No.	OPERATION	TYPE OF ENDS
3DE22	Gear Operated	RF
3DE23	Gear Operated	RTJ
3DE24	Gear Operated	WE

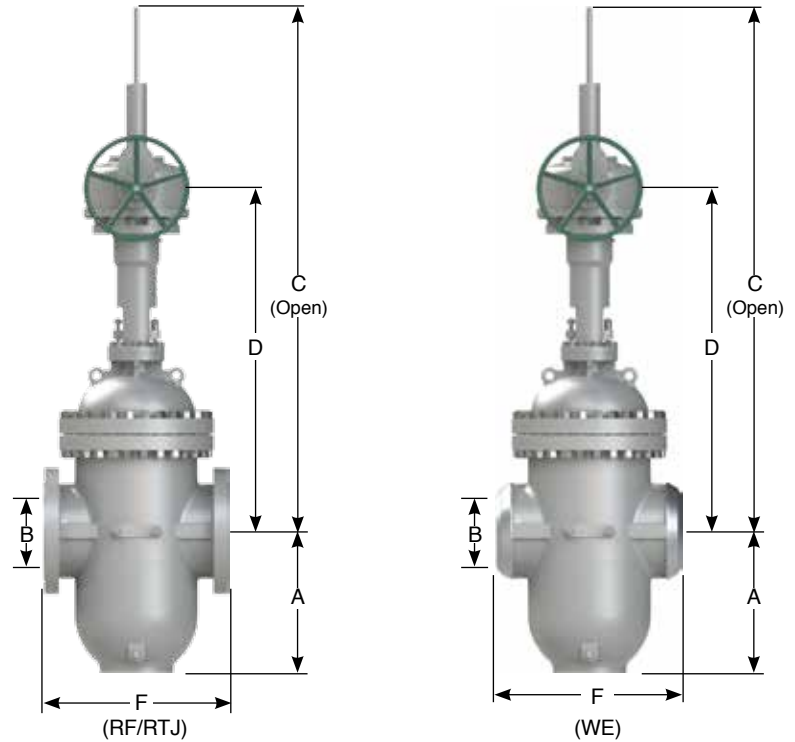

DIMENSIONS AND WEIGHTS

NOMINAL DIAMETER	mm	250	300	350	400	450	500	600	650	700
	in	10	12	14	16	18	20	24	26	28
A	mm	525	610	667	756	808	950	1130	1205	1255
	in	20.68	24.03	26.27	29.78	31.83	37.43	44.52	47.47	49.44
B	mm	252	303	334	385	436	487	589	633	684
	in	9.92	11.93	13.15	15.16	17.17	19.18	23.2	24.94	26.94
C (Open)	mm	1730	2001	2272	2464	2660	3082	3530	3803	3988
	in	68.11	78.78	89.45	97.01	104.72	121.34	138.98	149.72	157.01
D	mm	1067	1220	1422	1531	1646	1916	2145	2296	2355
	in	42.03	48.06	56.02	60.32	64.85	75.49	84.51	90.46	92.78
F (RF)	mm	457	502	762	838	914	991	1143	1245	1346
	in	18	19.77	30	33	36.01	39.04	45.03	49.05	53.03
F (RTJ)	mm	473	518	778	854	930	1010	1165	1270	1372
	in	18.63	20.4	30.625	33.62	36.64	39.79	45.9	50.03	54.05
F (WE)	mm	457	502	762	838	914	991	1143	1245	1346
	in	18	19.77	30	33	36.01	39.04	45.03	49.05	53.03
WEIGHT	kg	680	1030	2300	3190	2770	3560	5780	6560	7500
	lb	1499	2270	5070	7032	6106	7848	12742	14462	16534

Flanged Dimensions as per ASME/ANSI B16.34, B16.5 & B16.47

EXPANDING GATE VALVE ASME PRESSURE CLASS 300 (GEAR OPERATED)

DESIGN FEATURES

- a) Design in accordance with API-6D.
- b) Rising stem.
- c) Flanged dimensions as per ASME B16.5.
- d) For valves 26" and larger, flange dimensions as per ASME B16.47 Series A.
- e) End to end dimensions as per API-6D table 2 figure 1 (Valves not listed in this table as per ASME B16.10).
- f) WE dimensions as per ASME B31.4 and/or ASME B31.8 and tapered as per ASME B16.25 figure 1.
- g) Full opening through conduit.
- h) Sizes from 10" to 48" gear operator as standard.

FIGURE No.	OPERATION	TYPE OF ENDS
3DE22	Gear Operated	RF
3DE23	Gear Operated	RTJ
3DE24	Gear Operated	WE

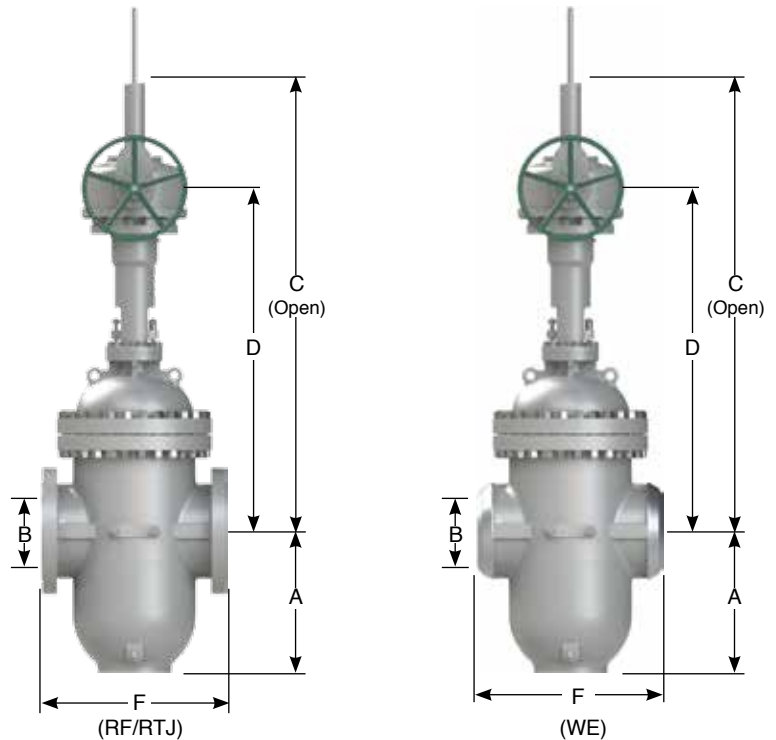

DIMENSIONS AND WEIGHTS

NOMINAL DIAMETER	mm	750	800	850	900	950	1000	1050	1200
	in	30	32	34	36	38	40	42	48
A	mm	1330	1400	1480	1540	1720	1795	1970	2120
	in	52.4	55.16	58.31	60.67	67.768	70.72	77.61	83.52
B	mm	735	779	830	874	925	976	1020	1166
	in	28.95	30.69	32.7	34.43	36.44	38.45	40.18	45.94
C (Open)	mm	4276	4521	4798	5070	5252	5614	5926	6478
	in	168.35	177.99	188.9	199.61	206.77	221.02	233.31	255.04
D	mm	2532	2706	2872	3044	3129	3393	3577	3828
	in	99.76	106.61	113.15	119.93	123.28	133.68	140.93	150.82
F (RF)	mm	1397	1524	1626	1727	1829	1946	2032	2337
	in	55.04	60.04	64.06	68.04	72.06	76.67	80.06	92.07
F (RTJ)	mm	1422	1553	1654	1756	-	-	-	-
	in	56.02	61.18	65.16	69.18	-	-	-	-
F (WE)	mm	1397	1524	1626	1727	1829	1946	2032	2337
	in	55.04	60.04	64.06	68.04	72.06	76.67	80.06	92.07
WEIGHT	kg	8600	9500	10800	12100	13600	17400	20350	30260
	lb	18959	20943	23809	26675	29982	38360	44863	66711

Flanged Dimensions as per ASME/ANSI B16.34, B16.5 & B16.47

EXPANDING GATE VALVE CLASS 600

WALWORTH offers this product line in the following base materials.

- a) Carbon steel as per ASTM A216 grades WCB, WCC.
- b) Carbon steel for NACE applications as per ASTM A216 grade WCB with 0.25% maximum and 22 HRc maximum hardness. CE= 0.43% maximum.

DESIGN FEATURES

- c) Design in accordance with API-6D.
- d) Double block & bleed (DDB). In closed position, the valve is capable to block both seat ports; the fluid can be released through the drain plug located in the middle of the seal sealing surfaces as per MMS-SP-61 specification.
- e) With double isolation & vent system (DIB) the valve block both ports. Then internal pressure can be released using the pressure relief valve located on the bonnet.
- f) Designed for positive sealing with Expanding Gate.
- g) Expanding gate design minimizes friction between closure members (gate and segment) against seats.
- h) Full through conduit port and full opening to permit pass of scrappers, pigs and wipers.
- i) Secondary reinforced viton O'rings to provide corrosion-resistance seal.
- j) Top entry, studded bonnet and replaceable seats for easy maintenance even in line.
- k) This valve complies with API-6D technical requirements for double isolation and bleed.
- l) 100% interchangeability of parts.
- m) Non lubricated.
- n) Bi-direccional seats offer double piston effect.
- o) Multi-position installation.
- p) Rising stem.
- q) Handwheel, chainwheel, gear operation, electric, pneumatic or hydraulic actuation is available as per Customer requirements.
- r) Hard faced options are available for severe service with Tungsten carbide, Chromium carbide applied by HVOF. Stellite coating also available upon request.
- s) Test in accordance with API-6D.
- t) Availability on raised face, butt weld or ring type joint ends.
- u) Valves from 8" nominal diameter and over are supplied with lifting lugs.

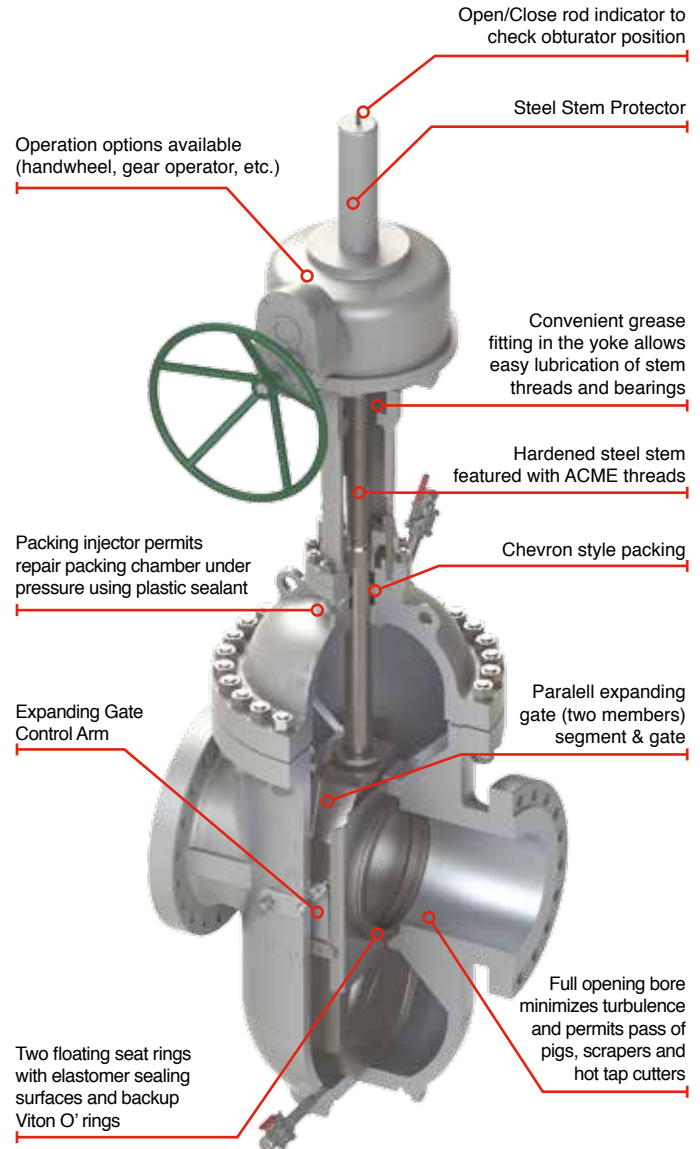

EXPANDING GATE VALVE ASME PRESSURE CLASS 600 (HANDWHEEL OPERATED)

DESIGN FEATURES

- a) Design in accordance with API-6D.
- b) Rising stem.
- c) Flanged dimensions as per ASME B16.5.
- d) For valves 26" and larger, flange dimensions as per ASME B16.47 Series A.
- e) End to end dimensions as per API-6D table 2 figure 1 (Valves not listed in this table as per ASME B16.10).
- f) WE dimensions as per ASME B31.4 and/or ASME B31.8 and tapered as per ASME B16.25 figure 1.
- g) Full opening through conduit.
- h) Sizes from 2" to 6" handwheel operated as standard.

FIGURE No.	OPERATION	TYPE OF ENDS
6DE12	Handwheel	RF
6DE13	Handwheel	RTJ
6DE14	Handwheel	WE

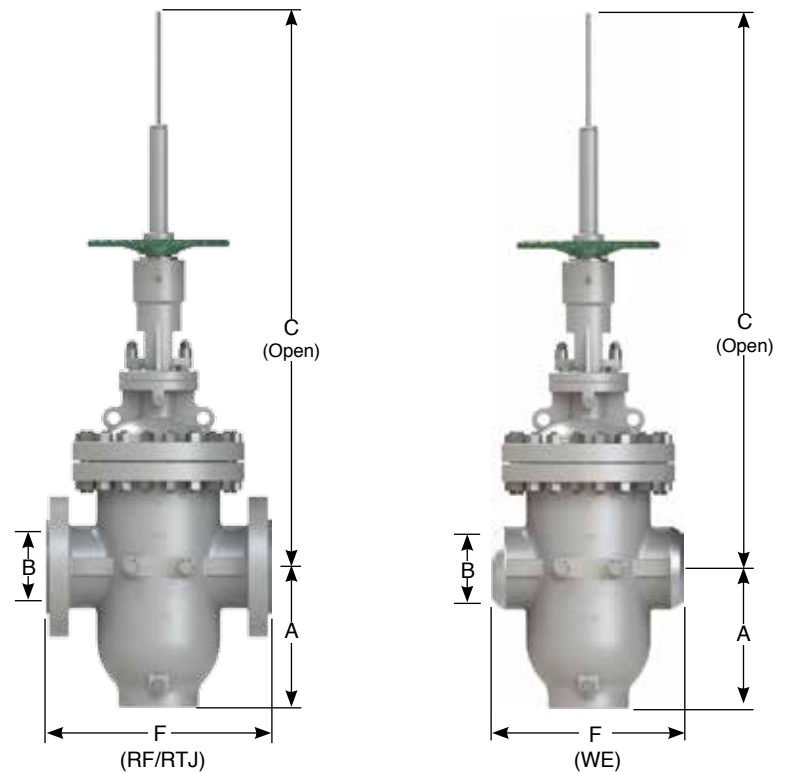

DIMENSIONS AND WEIGHTS

NOMINAL DIAMETER	mm	50	80	100	150
	in	2	3	4	6
A	mm	173	215	260	362
	in	6.8162	8.471	10.244	14.2628
B	mm	49	74	100	150
	in	1.9306	2.9156	3.94	5.91
C (Open)	mm	685	782	909	1261
	in	26.97	30.79	35.79	49.65
F (RF)	mm	292	356	432	559
	in	11.5048	14.0264	17.0208	22.0246
F (RTJ)	mm	295	359	435	562
	in	11.623	14.1446	17.139	22.1428
F (WE)	mm	292	356	432	559
	in	11.5048	14.0264	17.0208	22.0246
WEIGHT	kg	90	150	215	405
	lb	198.414	330.69	473.989	892.863

Flanged Dimensions as per ASME/ANSI B16.34, B16.5 & B16.47

EXPANDING GATE VALVE ASME PRESSURE CLASS 600 (GEAR OPERATED)

DESIGN FEATURES

- a) Design in accordance with API-6D.
- b) Rising stem.
- c) Flanged dimensions as per ASME B16.5.
- d) For valves 26" and larger, flange dimensions as per ASME B16.47 Series A.
- e) End to end dimensions as per API-6D table 2 figure 1 (Valves not listed in this table as per ASME B16.10).
- f) WE dimensions as per ASME B31.4 and/or ASME B31.8 and tapered as per ASME B16.25 figure 1.
- g) Full opening through conduit.
- h) Sizes from 8" to 48" gear operator as standard.

FIGURE No.	OPERATION	TYPE OF ENDS
6DE22	Gear Operated	RF
6DE23	Gear Operated	RTJ
6DE24	Gear Operated	WE

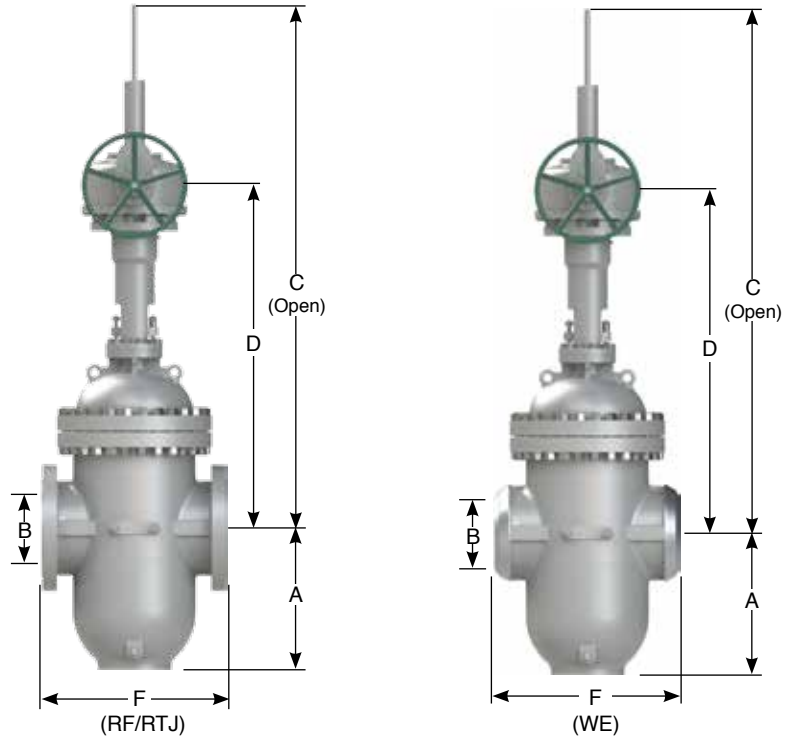

DIMENSIONS AND WEIGHTS

NOMINAL DIAMETER	mm	200	250	300	350	400	450	500	600	650
	in	8	10	12	14	16	18	20	24	26
A	mm	459	525	610	635	756	808	950	1170	1247
	in	18.08	20.68	24.03	25.01	29.78	31.83	37.43	46.09	49.13
B	mm	201	252	303	334	385	436	487	589	633
	in	7.92	9.92	11.93	13.15	15.16	17.17	19.18	23.2	24.94
C (Open)	mm	1469	1730	2001	2240	2464	2660	3082	3570	3845
	in	57.83	68.11	78.78	88.19	97.01	104.72	121.34	140.55	151.38
D	mm	927	1067	1220	1392	1531	1646	1916	2179	2331
	in	36.52	42.03	48.06	54.84	60.32	64.85	75.49	85.85	91.84
F (RF)	mm	660	787	838	889	991	1092	1194	1397	1448
	in	26	18	33	30.02	39.04	36.01	39.04	55.04	57.05
F (RTJ)	mm	664	791	841	892	994	1095	1200	1407	1461
	in	26.16	18.63	33.12	30.65	39.16	36.64	39.79	55.43	57.56
F (WE)	mm	660	787	838	889	991	1092	1194	1397	1448
	in	26	18	33	30.02	39.04	36.01	39.04	55.04	57.05
WEIGHT	kg	870	680	1030	1430	3190	2770	3560	7500	9770
	lb	1918	1499	2270	3152	7032	6106	7848	16534	21538

Flanged Dimensions as per ASME/ANSI B16.34, B16.5 & B16.47

EXPANDING GATE VALVE ASME PRESSURE CLASS 600 (GEAR OPERATED)

DESIGN FEATURES

- a) Design in accordance with API-6D.
- b) Rising stem.
- c) Flanged dimensions as per ASME B16.5.
- d) For valves 26" and larger, flange dimensions as per ASME B16.47 Series A.
- e) End to end dimensions as per API-6D table 2 figure 1 (Valves not listed in this table as per ASME B16.10).
- f) WE dimensions as per ASME B31.4 and/or ASME B31.8 and tapered as per ASME B16.25 figure 1.
- g) Full opening through conduit.
- h) Sizes from 8" to 48" gear operator as standard.

FIGURE No.	OPERATION	TYPE OF ENDS
6DE22	Gear Operated	RF
6DE23	Gear Operated	RTJ
6DE24	Gear Operated	WE

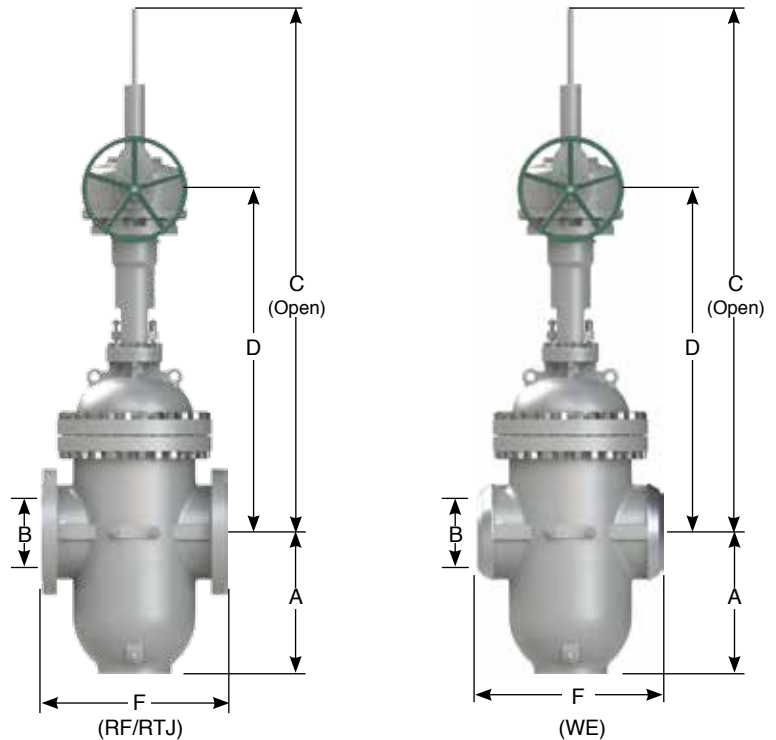

DIMENSIONS AND WEIGHTS

NOMINAL DIAMETER	mm	700	750	800	850	900	950	1000	1050	1200
	in	28	30	32	34	36	38	40	42	48
A	mm	1299	1376	1448	1530	1592	1774	1851	2028	2180
	in	51.18	54.21	57.05	60.28	62.72	69.89	72.92	79.9	85.89
B	mm	684	735	779	830	874	925	976	1020	1166
	in	26.94	28.95	30.69	32.7	34.43	36.44	38.45	40.18	45.94
C (Open)	mm	4032	4322	4569	4848	5122	5306	5670	5984	6538
	in	158.74	170.16	179.88	190.87	201.65	208.9	223.23	235.59	257.4
D	mm	2391	2569	2744	2911	3084	3170	3435	3620	3872
	in	94.2	101.21	108.11	114.69	121.5	124.89	135.33	142.62	152.55
F (RF)	mm	1549	1651	1778	1930	2083	2184	2286	2438	2794
	in	61.03	65.04	70.05	76.04	82.07	86.04	90.06	96.05	110.08
F (RTJ)	mm	1562	1664	1794	1946	2099	-	-	-	-
	in	61.54	65.56	70.68	76.67	82.7	-	-	-	-
F (WE)	mm	1549	1651	1778	1930	2083	2184	2286	2438	2794
	in	61.03	65.04	70.05	76.04	82.07	86.04	90.06	96.05	110.08
WEIGHT	kg	11600	13600	15600	17800	20600	24150	25235	27950	38700
	lb	25573	29982	34391	39241	53241	53241	55633	61618	85318

Flanged Dimensions as per ASME/ANSI B16.34, B16.5 & B16.47

EXPANDING GATE VALVE CLASS 900

WALWORTH offers this product line in the following base materials.

- a) Carbon steel as per ASTM A216 grades WCB, WCC.
- b) Carbon steel for NACE applications as per ASTM A216 grade WCB with 0.25% maximum and 22 HRc maximum hardness. CE= 0.43% maximum.

DESIGN FEATURES

- c) Design in accordance with API-6D.
- d) Double block & bleed (DDB). In closed position, the valve is capable to block both seat ports; the fluid can be released through the drain plug located in the middle of the seal sealing surfaces as per MMS-SP-61 specification.
- e) With double isolation & vent system (DIB) the valve block both ports. Then internal pressure can be released using the pressure relief valve located on the bonnet.
- f) Designed for positive sealing with Expanding Gate.
- g) Expanding gate design minimizes friction between closure members (gate and segment) against seats.
- h) Full through conduit port and full opening to permit pass of scrappers, pigs and wipers.
- i) Secondary reinforced viton O'rings to provide corrosion-resistance seal.
- j) Top entry, studded bonnet and replaceable seats for easy maintenance even in line.
- k) This valve complies with API-6D technical requirements for double isolation and bleed.
- l) 100% interchangeability of parts.
- m) Non lubricated.
- n) Bi-direccional seats offer double piston effect.
- o) Multi-position installation.
- p) Rising stem.
- q) Handwheel, chainwheel, gear operation, electric, pneumatic or hydraulic actuation is available as per Customer requirements.
- r) Hard faced options are available for severe service with Tungsten carbide, Chromium carbide applied by HVOF. Stellite coating also available upon request.
- s) Test in accordance with API-6D.
- t) Availability on raised face, butt weld or ring type joint ends.
- u) Valves from 8" nominal diameter and over are supplied with lifting lugs.

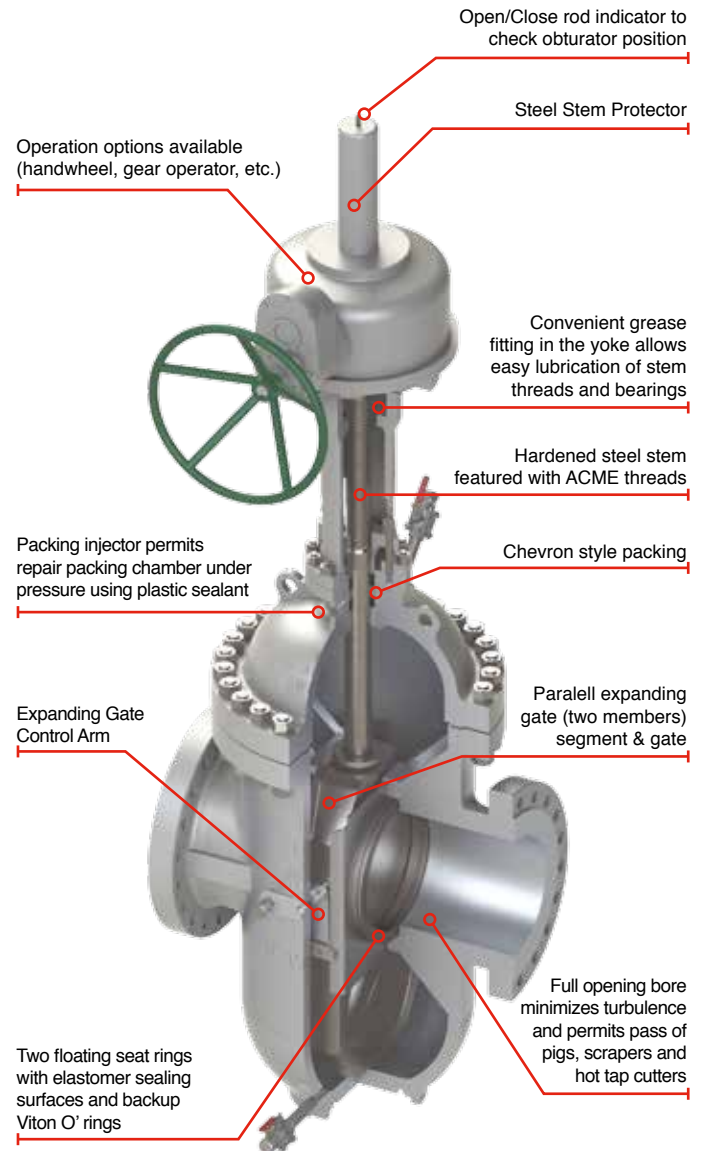

EXPANDING GATE VALVE ASME PRESSURE CLASS 900 (HANDWHEEL OPERATED)

DESIGN FEATURES

- a) Design in accordance with API-6D.
- b) Rising stem.
- c) Flanged dimensions as per ASME B16.5.
- d) For valves 26" and larger, flange dimensions as per ASME B16.47 Series A.
- e) End to end dimensions as per API-6D table 2 figure 1 (Valves not listed in this table as per ASME B16.10).
- f) WE dimensions as per ASME B31.4 and/or ASME B31.8 and tapered as per ASME B16.25 figure 1.
- g) Full opening through conduit.
- h) Sizes from 2" to 4" handwheel operated as standard.

FIGURE No.	OPERATION	TYPE OF ENDS
9DE12	Handwheel	RF
9DE13	Handwheel	RTJ
9DE14	Handwheel	WE

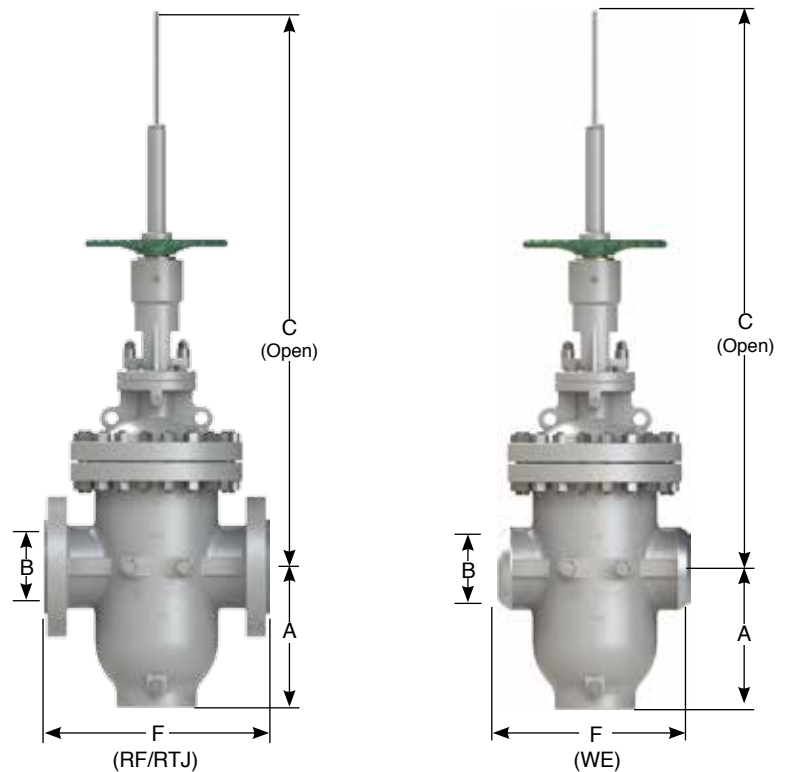

DIMENSIONS AND WEIGHTS

NOMINAL DIAMETER	mm	50	80	100
	in	2	3	4
A	mm	206	233	261
	in	8.11	9.18	10.28
B	mm	49	74	100
	in	1.93	2.91	3.94
C (Open)	mm	680	774	939
	in	26.77	30.47	36.97
F (RF)	mm	368	381	457
	in	14.49	15.01	18
F (RTJ)	mm	371	384	460
	in	14.61	15.12	18.12
F (WE)	mm	368	381	457
	in	14.49	15.01	18
WEIGHT	kg	105	220	390
	lb	231	485	859

Flanged Dimensions as per ASME/ANSI B16.34, B16.5 & B16.47

EXPANDING GATE VALVE ASME PRESSURE CLASS 900 (GEAR OPERATED)

DESIGN FEATURES

- a) Design in accordance with API-6D.
- b) Rising stem.
- c) Flanged dimensions as per ASME B16.5.
- d) For valves 26" and larger, flange dimensions as per ASME B16.47 Series A.
- e) End to end dimensions as per API-6D table 2 figure 1 (Valves not listed in this table as per ASME B16.10).
- f) WE dimensions as per ASME B31.4 and/or ASME B31.8 and tapered as per ASME B16.25 figure 1.
- g) Full opening through conduit.
- h) Sizes from 6" to 24" gear operator as standard.

FIGURE No.	OPERATION	TYPE OF ENDS
9DE22	Gear Operated	RF
9DE23	Gear Operated	RTJ
9DE24	Gear Operated	WE

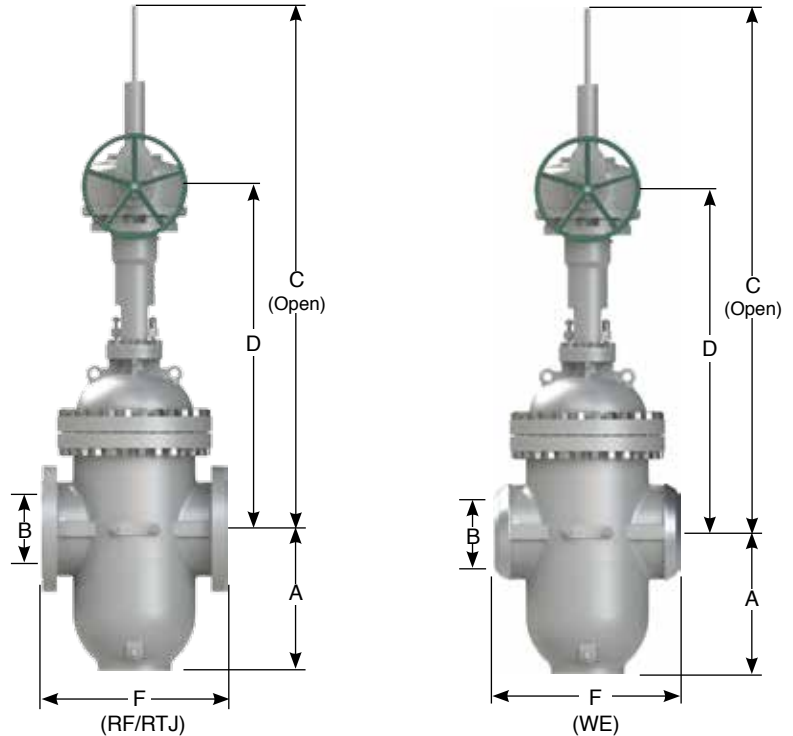

DIMENSIONS AND WEIGHTS

NOMINAL DIAMETER	mm	150	200	250	300	350	400	450	500	600
	in	6	8	10	12	14	16	18	20	24
A	mm	367	459	556	658	724	810	906	1007	1208
	in	14.45	18.08	21.9	25.92	28.52	31.91	35.69	39.67	47.59
B	mm	150	201	252	303	322	373	423	471	570
	in	5.91	7.91	9.92	11.93	12.68	14.69	16.66	18.55	22.45
C (Open)	mm	1310	1567	1927	2186	2307	2638	2911	3149	3606
	in	51.57	61.69	75.87	86.06	90.83	103.86	114.61	123.98	141.97
D	mm	844	985	1223	1368	1439	1658	1833	1960	2207
	in	33.25	38.8	48.18	53.89	56.69	65.32	72.22	77.22	86.95
F (RF)	mm	610	737	838	965	1029	1130	1219	1321	1549
	in	24.03	29.03	33.01	38.02	40.54	44.52	48.02	52.04	61.03
F (RTJ)	mm	613	740	841	968	1038	1140	1232	1334	1568
	in	24.15	29.15	33.13	38.13	40.89	44.91	48.54	52.55	61.77
F (WE)	mm	610	737	838	965	1029	1130	1219	1321	1549
	in	24.03	29.03	33.01	38.02	40.54	44.52	48.02	52.04	61.03
WEIGHT	kg	725	1320	1770	2720	3530	4360	5430	6950	12750
	lb	1598	2910	3902	5996	7782	9612	11970	15321	28108

Flanged Dimensions as per ASME/ANSI B16.34, B16.5 & B16.47

EXPANDING GATE VALVE CLASS 1500

WALWORTH offers this product line in the following base materials.

- a) Carbon steel as per ASTM A216 grades WCB, WCC.
- b) Carbon steel for NACE applications as per ASTM A216 grade WCB with 0.25% maximum and 22 HRc maximum hardness. CE= 0.43% maximum.

DESIGN FEATURES

- c) Design in accordance with API-6D.
- d) Double block & bleed (DDB). In closed position, the valve is capable to block both seat ports; the fluid can be released through the drain plug located in the middle of the seal sealing surfaces as per MMS-SP-61 specification.
- e) With double isolation & vent system (DIB) the valve block both ports. Then internal pressure can be released using the pressure relief valve located on the bonnet.
- f) Designed for positive sealing with Expanding Gate.
- g) Expanding gate design minimizes friction between closure members (gate and segment) against seats.
- h) Full through conduit port and full opening to permit pass of scrappers, pigs and wipers.
- i) Secondary reinforced viton O'rings to provide corrosion-resistance seal.
- j) Top entry, studded bonnet and replaceable seats for easy maintenance even in line.
- k) This valve complies with API-6D technical requirements for double isolation and bleed.
- l) 100% interchangeability of parts.
- m) Non lubricated.
- n) Bi-direccional seats offer double piston effect.
- o) Multi-position installation.
- p) Rising stem.
- q) Handwheel, chainwheel, gear operation, electric, pneumatic or hydraulic actuation is available as per Customer requirements.
- r) Hard faced options are available for severe service with Tungsten carbide, Chromium carbide applied by HVOF. Stellite coating also available upon request.
- s) Test in accordance with API-6D.
- t) Availability on raised face, butt weld or ring type joint ends.
- u) Valves from 8" nominal diameter and over are supplied with lifting lugs.

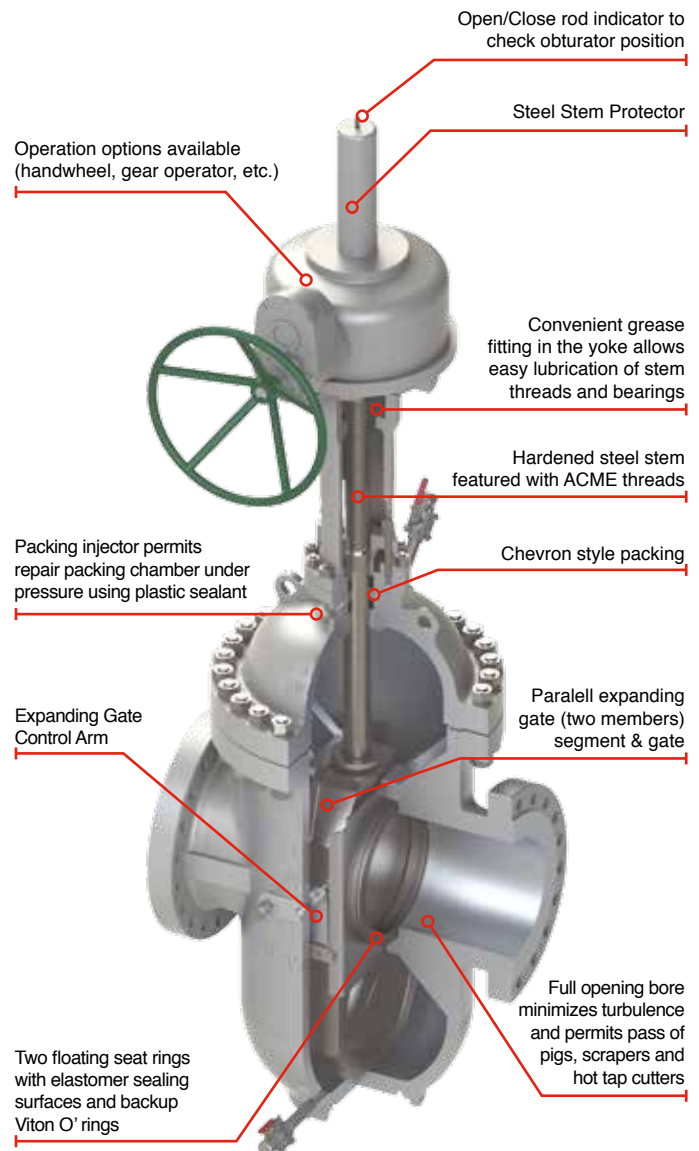

EXPANDING GATE VALVE ASME PRESSURE CLASS 1500 (HANDWHEEL OPERATED)

DESIGN FEATURES

- a) Design in accordance with API-6D.
- b) Rising stem.
- c) Flanged dimensions as per ASME B16.5.
- d) For valves 26" and larger, flange dimensions as per ASME B16.47 Series A.
- e) End to end dimensions as per API-6D table 2 figure 1 (Valves not listed in this table as per ASME B16.10).
- f) WE dimensions as per ASME B31.4 and/or ASME B31.8 and tapered as per ASME B16.25 figure 1.
- g) Full opening through conduit.
- h) Sizes from 2" to 3" handwheel operated as standard.

FIGURE No.	OPERATION	TYPE OF ENDS
5DE12	Handwheel	RF
5DE13	Handwheel	RTJ
5DE14	Handwheel	WE

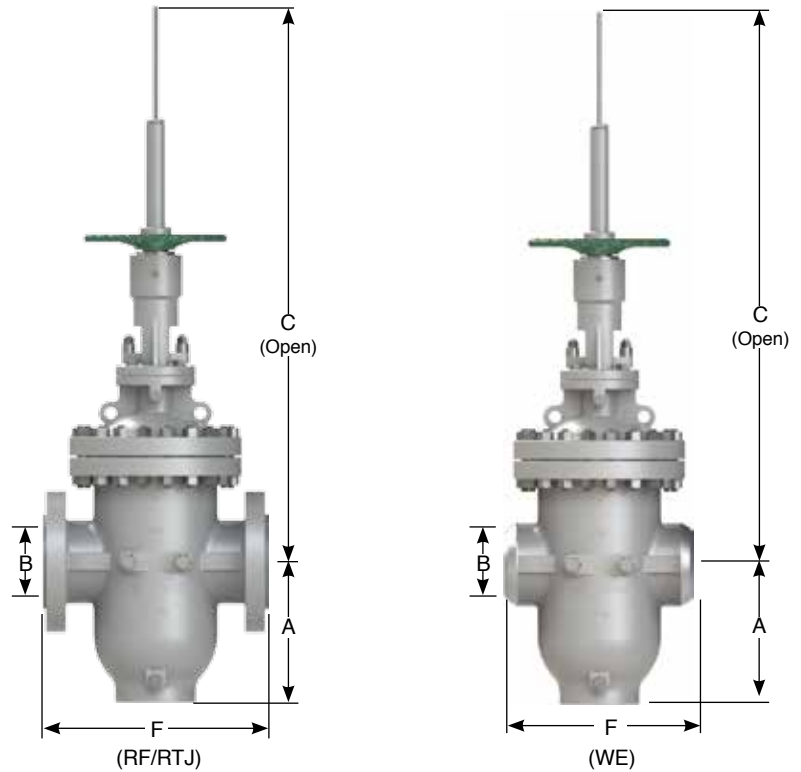

DIMENSIONS AND WEIGHTS

NOMINAL DIAMETER	mm	50	80
	in	2	3
A	mm	200	225
	in	7.88	8.86
B	mm	49	74
	in	1.93	2.91
C (Open)	mm	656	748
	in	25.83	29.45
F (RF)	mm	368	470
	in	14.49	18.51
F (RTJ)	mm	371	473
	in	14.61	18.63
F (WE)	mm	368	470
	in	14.49	18.51
WEIGHT	kg	165	355
	lb	363	782

Flanged Dimensions as per ASME/ANSI B16.34, B16.5 & B16.47

EXPANDING GATE VALVE ASME PRESSURE CLASS 1500 (GEAR OPERATED)

DESIGN FEATURES

- a) Design in accordance with API-6D.
- b) Rising stem.
- c) Flanged dimensions as per ASME B16.5.
- d) For valves 26" and larger, flange dimensions as per ASME B16.47 Series A.
- e) End to end dimensions as per API-6D table 2 figure 1 (Valves not listed in this table as per ASME B16.10).
- f) WE dimensions as per ASME B31.4 and/or ASME B31.8 and tapered as per ASME B16.25 figure 1.
- g) Full opening through conduit.
- h) Sizes from 4" to 24" gear operator as standard.

FIGURE No.	OPERATION	TYPE OF ENDS
5DE22	Gear Operated	RF
5DE23	Gear Operated	RTJ
5DE24	Gear Operated	WE

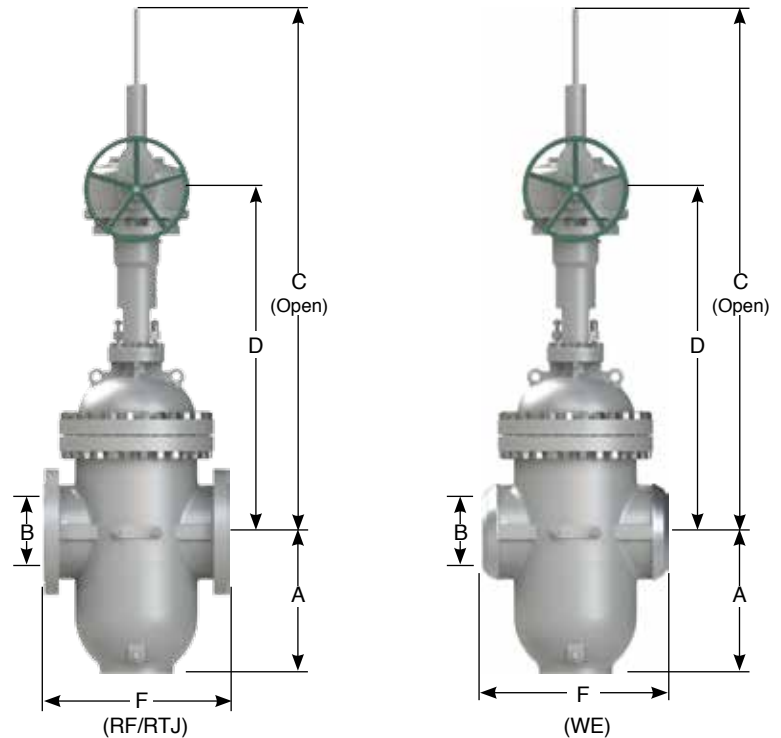

DIMENSIONS AND WEIGHTS

NOMINAL DIAMETER	mm	100	150	200	250	300	350	400	450	500	600
	in	4	6	8	10	12	14	16	18	20	24
A	mm	251	355	445	540	640	704	788	882	981	1180
	in	9.88	13.98	17.53	21.27	25.21	27.73	31.04	34.75	38.65	46.49
B	mm	100	144	192	239	287	315	360	406	454	546
	in	3.94	5.67	7.56	9.41	11.3	12.41	14.18	15.99	17.88	21.51
C (Open)	mm	960	1273	1524	1879	2129	2251	2572	2836	3046	3511
	in	37.8	50.12	60	73.98	83.82	88.62	101.26	111.65	119.92	138.23
D	mm	-	832	977	1223	1361	1416	1642	1803	1952	2183
	in	-	32.78	38.49	48.18	53.62	55.79	64.69	71.03	76.9	86.01
F (RF)	mm	546	705	832	991	1130	1257	1384	1537	1664	1943
	in	21.51	27.77	32.78	39.04	44.52	49.52	54.52	60.55	65.56	76.55
F (RTJ)	mm	549	711	841	1000	1146	1276	1407	1559	1686	1972
	in	21.63	28.01	33.13	39.4	45.15	50.27	55.43	61.42	66.42	77.69
F (WE)	mm	546	705	832	991	1130	1257	1384	1537	1664	1943
	in	21.51	27.77	32.78	39.04	44.52	49.52	54.52	60.55	65.56	76.55
WEIGHT	kg	520	1230	2060	3090	4500	6250	8050	10200	14400	23400
	lb	1146	2711	4541	6812	9920	13778	17747	22486	31746	51587

Flanged Dimensions as per ASME/ANSI B16.34, B16.5 & B16.47

MOST COMMON TRIM ARRANGEMENTS

METAL TO SOFT SEAT

FEATURES	METAL TO SOFT SEAT		
DESCRIPTION	ES1	ES2	ES3
TEMPERATURE	-20°F to 250°F	-20°F to 250°F	-20°F to 250°F
	(-29°C to 121°C)	(-29°C to 121°C)	(-29°C to 121°C)
SERVICE	STANDARD TRIM FOR GENERAL, ENERGY, GAS AND OIL SERVICE	FOR CORROSION RESISTANCE SERVICE	TRIM FOR GENERAL, ENERGY, GAS AND OIL SERVICE
GATE & SEGMENT	WCB, WCC or A105N + ENP (0.003")	SS410 + ENP (0.003")	WCB, WCC or A105N + ENP (0.003")
SEAT RING	A105N+ENP (0.003")	SS410 + ENP (0.003")	A105N+ENP (0.003")
SEAT RING INSERT	RPTFE OR NYLON SOFT SEAL (SEE TABLE 1)	RPTFE OR NYLON SOFT SEAL (SEE TABLE 1)	RPTFE OR NYLON SOFT SEAL (SEE TABLE 1)
STEM	AISI 4140+ENP (0.003")	SS 410	17-4PH

METAL TO METAL SEAT

FEATURES	METAL TO METAL SEAT					
DESCRIPTION	EM1	EM2	EM3	EM4	EM5	EM6
TEMPERATURE	-20°F to 550°F	-20°F to 550°F	-20°F to 550°F	-20°F to 550°F	-20°F to 550°F	-20°F to 550°F
	(-29°C to 288°C)	(-29°C to 288°C)	(-29°C to 288°C)	(-29°C to 288°C)	(-29°C to 288°C)	(-29°C to 288°C)
SERVICE	HIGH TEMPERATURE AND ABRASIVE RESISTANCE SERVICE	HIGH TEMPERATURE, ABRASIVE AND CORROSION RESISTANCE SERVICE	HIGH TEMPERATURE AND ABRASIVE RESISTANCE SERVICE	HIGH TEMPERATURE, ABRASIVE AND CORROSION RESISTANCE SERVICE	HIGH TEMPERATURE AND ABRASIVE RESISTANCE SERVICE	HIGH TEMPERATURE, ABRASIVE AND CORROSION RESISTANCE SERVICE
GATE & SEGMENT	WCB, WCC or A105N + TUNGSTEN CARBIDE*	SS 410 + TUNGSTEN CARBIDE*	WCB, WCC or A105N + STELLITE 6*	SS 410 + STELLITE 6*	WCB, WCC or A105N + CHROMIUM CARBIDE*	SS 410 + CHROMIUM CARBIDE*
SEAT RING	A105N + TUNGSTEN CARBIDE*	SS 410 + TUNGSTEN CARBIDE*	A105N + STELLITE 6*	SS 410 + STELLITE 6*	A105N + CHROMIUM CARBIDE*	SS 410 + CHROMIUM CARBIDE*
SEAT RING INSERT	-(METAL TO METAL SEAL)	-(METAL TO METAL SEAL)	-(METAL TO METAL SEAL)	-(METAL TO METAL SEAL)	-(METAL TO METAL SEAL)	-(METAL TO METAL SEAL)
STEM	SS 410	SS 410	SS 410	SS 410	SS 410	SS 410

*Hard Overlay is normally of 0.006" thickness

Notes:

- a. Special arrangements can be supplied as per Customers request.
- b. All valves are suitable for Sour Service as they comply with NACE MR0175

MOST COMMON TRIM ARRANGEMENTS

SOFT SEAT INSERT MATERIALS (PRESSURE-TEMPERATURE)

CLASS	Size	TEMPERATURE °F (°C)					
		100 (38)	200 (93)	300 (149)	400 (204)	500 (260)	600 (316)
150	All	RPTFE-15%	RPTFE-15%	RPTFE-15%	RPTFE-15%	RPTFE-15%	RPTFE-15%
300	2 to 24	RPTFE-15%	RPTFE-15%	RPTFE-15%	RPTFE-15%	PEEK	PEEK
300	24 and up	NYLON 6	NYLON 6	MOLON	MOLON	PEEK	PEEK
600	2 to 12	RPTFE-15%	RPTFE-15%	MOLON	MOLON	PEEK	PEEK
600	14 and up	NYLON 6	NYLON 6	MOLON	MOLON	PEEK	PEEK
900	All	NYLON 6	NYLON 6	MOLON	PEEK	PEEK	PEEK
1500	All	NYLON 6	NYLON 6	PEEK	PEEK	PEEK	PEEK

- "O"-Ring HNBR (AED) must be used as secondary seal
- "O"-Ring VITON A&B FKM (AED) must be used as secondary seal
- PEEK/RPTFE seals must be used as secondary seal



API 6D THROUGH CONDUIT EXPANDING GATE VALVE (SOFT SEAT), OPERATOR SIZING REQUIREMENTS

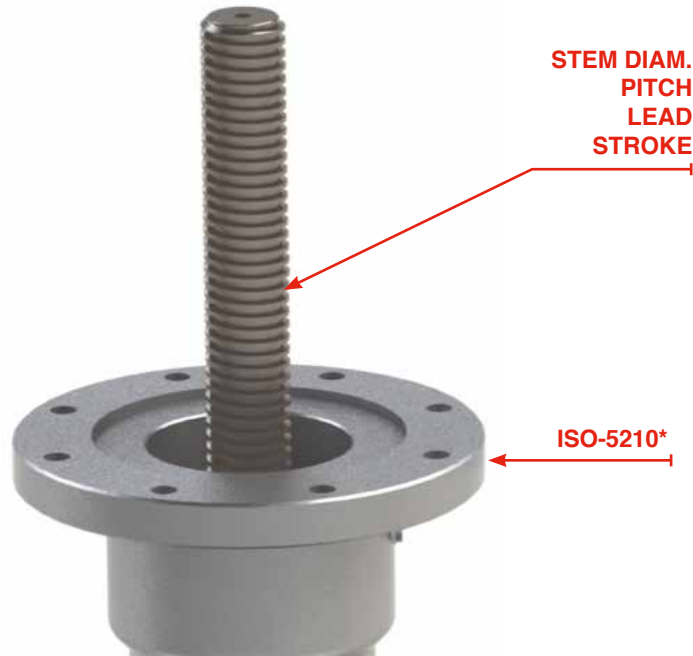

* WALWORTH Expanding Gate Valves with gear operator are supplied with ISO flanges in accordance with ISO-5210. Bare stem valves will be supplied with ISO flange upon request.

SIZE In (mm)	ASME CLASS	ASME WORKING PRESSURE	STEM In	PITCH In	LEAD In	TORQUE (lbf-ft)	THRUST (lbf)	STROKE In	TURNS OF STEM	ISO-5210
2 (50)	150	290	7/8"-6	1/6"	single	4	675	3.164	20	F10
	300	750	7/8"-6	1/6"	single	19	1574	3.164	20	F10
	600	1500	7/8"-6	1/6"	single	19	3597	3.164	20	F10
3 (80)	150	290	7/8"-6	1/6"	single	6	1124	4.163	27	F10
	300	750	1"-5	1/5"	single	16	2698	4.2	21	F10
	600	1500	1"-5	1/5"	single	35	5845	4.2	21	F10
4(100)	150	290	1"-5	1/5"	single	11	1574	5.2	26	F10
	300	750	1 1/8"-5	1/5"	single	27	3822	5.2	26	F12
	600	1500	1 1/8"-5	1/5"	single	59	8543	5.2	26	F12

Note: Recommended thrust and torque for sizing bevel gear or automation. This data includes a 20 % safety factor about torque information.

Continues...

API 6D THROUGH CONDUIT EXPANDING GATE VALVE (SOFT SEAT), OPERATOR SIZING REQUIREMENTS

SIZE In (mm)	ASME CLASS	ASME WORKING PRESSURE	STEM In	PITCH In	LEAD In	TORQUE (lbf-ft)	THRUST (lbf)	STROKE In	TURNS OF STEM	ISO-5210
6(150)	150	290	1 1/8"-5	1/5"	single	20	2923	7.6	37	F12
	300	750	1 1/4"-5	1/5"	single	58	7419	7.6	38	F14
	600	1500	1 3/8"-4	1/4"	single	137	16186	7.28	30	F16
8(200)	150	290	1 1/4"-5	1/5"	single	42	4946	9.5	48	F14
	300	750	1 3/8"-4	1/4"	single	105	12365	9.5	38	F16
	600	1500	1 7/8"-4	1/4"	single	341	28551	9.76	40	F25
10(250)	150	290	1 3/8"-4	1/4"	single	65	7644	12	47	F16
	300	750	1 5/8"-4	1/4"	single	195	19109	12	48	F16
	600	1500	2"-4	1/4"	single	615	43388	12	36	F25
12(300)	150	290	1 1/2"-4	1/4"	single	100	10566	14	56	F16
	300	750	1 5/8"-4	1/4"	single	270	26303	14	56	F25
	600	1500	2 1/4"-3	1/3"	single	834	58675	14	42	F30
14(350)	150	290	1 5/8"-4	1/4"	single	136	13264	15	62	F16
	300	750	1 3/4"-4	1/4"	single	368	33047	15	62	F25
	600	1500	2 1/2"-3	1/3"	single	1154	72613	15.28	46	F30
16(400)	150	290	1 3/4"-4	1/4"	single	188	16861	17.5	70	F25
	300	750	2"-4	1/4"	single	545	42713	17.5	71	F25
	600	1500	2 1/2"-3	1/3"	single	1466	92171	18.007	54	F30
18(500)	150	290	1 3/4"-4	1/4"	single	233	21132	19.25	78	F25
	300	750	2 1/8"-3	1/3"	single	704	52605	19.34	58	F25
	600	1500	3 1/4"-2	1/2"	single	2395	116900	19.29	39	F35
20(500)	150	290	2"-4	1/4"	single	334	26078	21.500	86	F25
	300	750	2 1/2"-3	1/3"	single	1038	65194	22.009	66	F30
	600	1500	3 1/2"-2	1/2"	single	3168	142754	22.000	44	F35

Note: Recommended thrust and torque for sizing bevel gear or automation. This data includes a 20 % safety factor about torque information.

Continues...

API 6D THROUGH CONDUIT EXPANDING GATE VALVE (SOFT SEAT), OPERATOR SIZING REQUIREMENTS

SIZE In (mm)	ASME CLASS	ASME WORKING PRESSURE	STEM In	PITCH In	LEAD In	TORQUE (lb-ft)	THRUST (lb)	STROKE In	TURNS OF STEM	ISO-5210
24(600)	150	290	2 1/8"-3	1/3"	single	486	36419	25.677	78	F25
	300	750	3"-2	1/2"	single	1742	92846	26.000	52	F35
	600	1500	3 3/4"-2	1/2"	single	5066	211994	26.500	53	F40
30(750)	150	290	2 1/2"-3	1/3"	single	910	57101	32.013	96	F30
	300	750	3 1/8"-2	1/2"	single	3220	145001	33.000	66	F40
	600	1500	4 3/4"	1/2"	single	9478	313383	31	64	F48
36(900)	150	290	3"-2	1/2"	single	1780	79132	37.000	75	F35
	300	750	4"-2	1/2"	single	6093	198056	37.000	75	F40
	600	1500	5 1/8"-2	1/2"	single	14042	490082	37.165	75	F48

Note: Recommended thrust and torque for sizing bevel gear or automation. This data includes a 20 % safety factor about torque information.

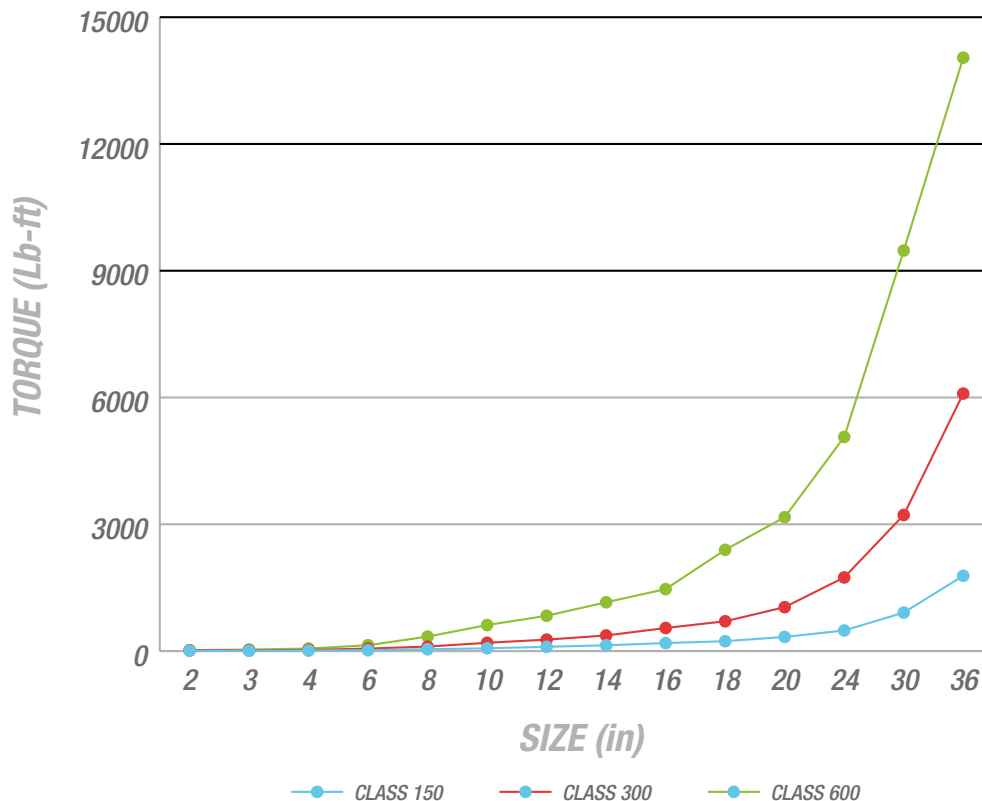

TECHNICAL INFORMATION

TYPES OF END CONNECTIONS

WALWORTH Expanding Gate Valves can be supplied with flanged ends in raised face, flat faces or ring joint type as well as in welding ends (butt weld). They can also be supplied with combined ends, such as flanged by weld, in accordance to customer requirements.

The butt weld ends in standard valves are machined in accordance with ASME B 31.4 and/or ASME B 31.8 and tapered as per ASME B16.5 figure 1; are supplied to meet the following pipe schedules:

Valve Pressure Class	Weld End Pipe Schedule
150/300	Schedule 40 – 2" to 10" Standard Wall – 12" to 24"
600	Schedule 80
900	Schedule 160 – 2" to 3" Schedule 120 – 4" and Larger
1500	Schedule 160

The customer must clearly specify the pipe wall thickness and type of pipe to be welded to the valves for schedules different than the above.

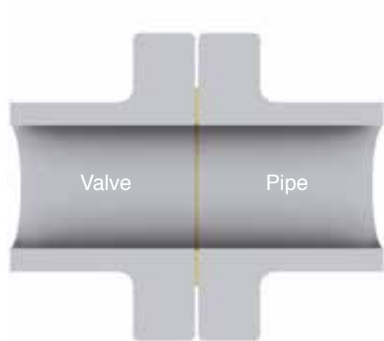

Flanged Ends
Flat Face

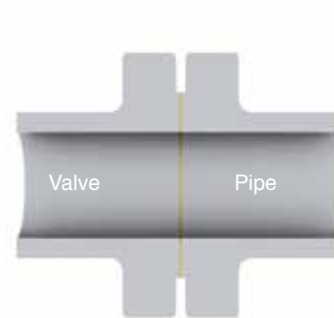

Flanged Ends
Raised Face

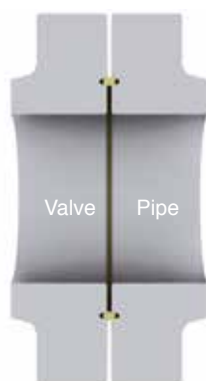

Flanged Ends
Ring Type Joint

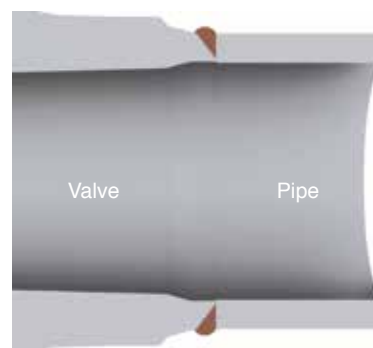

Weld Ends Butt weld

TECHNICAL INFORMATION

TYPE OF OPERATORS

The WALWORTH standard expanding gate product line includes many different valves designed to meet most applications.

Special adaptations can be made to meet specific customer requirements. Valves can be supplied with manual handwheel/gear operation, chain wheel, as well as electric, pneumatic and hydraulic actuators. This makes it possible for WALWORTH to furnish valves adapted to the customers special needs such as controlled opening/closing and remote installation.

Valves can also be supplied with a bypass, drain or vent connection, stem extension, position indicators and floor stand mounting.



Gear Operators

A manual gear operator is designed with a bevel gear and pinion ratio sized to transmit the required opening/closing torque with normal operator effort on the handwheel. They can be supplied as waterproof units and/or for underground installation with a square operating nut.



Chain Wheel Operation

Chain Wheels are designed for operating valves installed in remote or inaccessible locations. They can (PHOTO) be furnished with roller guides to prevent the chain from jumping off the wheel. Impact type chain wheels are also available to assist in unseating a tightly closed valve



Actuators

Valves can be furnished with either electric, pneumatic or hydraulic actuators. The actuators can be furnished as either waterproof and/or explosion proof. The customer must specify such things as open-close speed, maximum differential pressure, service temperature, type of voltage-phase-frequency, air or gas pressure for pneumatic actuators and flow characteristics for hydraulic actuators to be assured of correct performance.

LOCKING DEVICE

Upon request, WALWORTH expanding gate valves can be supplied with locking device.



PRESSURE-TEMPERATURE RATINGS

PRESSURE-TEMPERATURE GRAPH STEELS

CAST STEEL ASTM A 216 GR WCB-WCC

Temperature		Maximum allowable non-shock working pressure in PSIG by class					
°F	°C	150	300	600	900	1500	2500
-20 to 100	-29 to 38	285	740	1480	2220	3705	6170
200	93	260	680	1360	2035	3395	5655
300	149	230	655	1310	1965	3270	5450
400	204	200	635	1265	1900	3170	5280
500	260	170	605	1205	1810	3015	5025
600	316	140	570	1135	1705	2840	4730
650	343	125	550	1100	1650	2745	4575
700	371	110	530	1060	1590	2665	4425
750	399	98	505	1015	1520	2535	4230
800	427	80	410	825	1235	2055	3430
850	454	65	320	640	955	1595	2655
900	482	50	230	460	690	1150	1915
950	510	35	135	275	410	685	1145
1000	538	20	85	170	255	430	715

Note: Upon prolonged exposure to temperatures above 800°F, the carbide phase of steel may be converted to graphite. Permissible, but not recommended for prolonged use above 800°F.

CAST STEEL ASTM A 352 GR LCB-LCC

Temperature		Maximum allowable non-shock working pressure in PSIG by class					
°F	°C	150	300	600	900	1500	2500
-20 to 100	-29 to 38	265	695	1395	2090	3480	5805
200	93	255	660	1320	1980	3300	5505
300	149	230	640	1275	1915	3190	5315
400	204	200	615	1230	1845	3075	5125
500	260	170	585	1175	1760	2930	4885
600	316	140	550	1105	1655	2755	455
650	343	125	535	1065	1600	2665	4440
700	371	110	510	1025	1535	2560	4270
750	399	95	475	955	1430	2385	3970
800	427	80	390	780	1175	1955	3255
850	454	65	300	595	895	1490	2485
900	482	50	200	405	605	1010	1685
950	510	35	135	275	410	685	1145
1000	538	20	85	170	255	430	715

Note: Not to be used over 650°F.

PRESSURE-TEMPERATURE RATINGS

CAST STEEL ASTM A 351 GR CF8M

Temperature		Maximum allowable non-shock working pressure in PSIG by class					
°F	°C	150	300	600	900	1500	2500
-20 to 100	-29 to 38	275	720	1440	2160	3600	6000
200	93	235	620	1240	1860	3095	5160
300	149	215	560	1120	1680	2795	4660
400	204	195	515	1025	1540	2570	4280
500	260	170	480	955	1435	2390	3980
600	316	140	450	900	1355	2255	3760
650	343	125	440	885	1325	2210	3680
700	371	110	435	870	1305	2170	3620
750	399	95	425	855	1280	2135	3560
800	427	80	420	745	1265	2110	3520
850	454	65	420	735	1255	2090	3480
900	482	50	415	730	1245	2075	3460
950	510	35	385	775	1160	1930	3220
1000	538	20	365	725	1090	1820	3030
1050	566	20	360	720	1080	1800	3000
1100	593	20(a)	305	610	915	1525	2545
1150	621	20(a)	235	475	710	1185	1970
1200	649	20(a)	185	370	555	925	1545
1250	677	20(a)	145	295	440	735	1230
1300	704	20(a)	115	235	350	585	970
1350	732	20(a)	95	190	290	480	800
1400	760	20(a)	75	150	225	380	630
1450	788	20(a)	60	115	175	290	475
1500	816	15(a)	40	85	125	205	345

Notes:

- At temperatures over 1,000°F, use only when the carbon content is 0.04% or higher.
- (a) For welding ends valves only. Flanged ends ratings terminate at 1000°F (538°C).

PRESSURE-TEMPERATURE RATINGS

CAST STEEL ASTM A 351 GR CF8

Temperature		Maximum allowable non-shock working pressure in PSIG by class					
°F	°C	150	300	600	900	1500	2500
-20 to 100	-29 to 38	275	720	1440	2160	3600	6000
200	93	230	600	1200	1800	3000	5000
300	149	205	540	1075	16154	2690	4480
400	204	190	495	995	1490	2485	4140
500	260	170	465	9320	1395	2330	3880
600	316	140	440	885	1325	2210	3680
650	343	125	430	865	1295	2160	3600
700	371	110	420	845	1265	2110	3520
750	399	95	415	825	1240	2065	3440
800	427	80	405	710	1215	2030	3380
850	454	65	395	790	1190	1980	3300
900	482	50	390	780	1165	1945	3240
950	510	35	380	765	1145	1910	3180
1000	538	20	355	710	1065	1770	2950
1050	566	20(a)	325	650	975	1630	2715
1100	593	20(a)	255	515	770	1285	2145
1150	621	20(a)	205	410	615	1030	1715
1200	649	20(a)	165	330	495	825	1370
1250	677	20(a)	135	265	400	970	1115
1300	704	20(a)	115	225	340	565	945
1350	732	20(a)	95	185	280	465	770
1400	760	20(a)	75	150	225	380	630
1450	788	20(a)	60	115	175	290	485
1500	816	15(a)	40	85	125	205	345

Notes:

- At temperatures over 1,000°F, use only when the carbon content is 0.04% or higher.
- (a) For welding ends valves only. Flanged ends ratings terminate at 1000°F (538°C).

DESIGN BASIS

All of WALWORTH's valve designs, when applicable, follow one or more of the following standards.

- API** American Petroleum Institute.
6D Steel gate, ball and plug valves for pipeline service.
6FA Specification for Fire Test for Valves.
- ASME/ANSI** American National Standard Institute:
B2.1 Pipe threads.
B16.5 Steel pipe Flanges and flanged fittings.
B16.10 Length of ferrous flanged and welding end valves.
B16.25 Butt-welding ends.
B18.2 Square and hexagon bolts and nuts.
B16.47 Large Diameter Steel Flanges
- ASTM** American Society for Testing and Materials:
A-193 Alloy steel bolting material for high temperature service.
A-194 Carbon and alloy steel nuts for high pressure and high temperature service, class2.
A-216 Standard specification for steel castings, Carbon, Suitable for Fusion Welding, for High-temperature Service.
- MSS** Manufactures Standardization Society of the Valve and Fittings:
SP-25 Standard marking system for valves, fittings, flanges and unions.
SP-44 Steel pipe line flanges.
SP-47 Limiting dimensions of raised face flange gaskets.
SP-61 Pressure testing of steel valves.
- ASME** American Society of Mechanical Engineers:
Section II Part A, B and C.
Section V Non-destructive Tests.
Section VIII Boiler and Pressure Vessel Code for Unfired Pressure Vessels, Divisions 1 and 2.
Section IX Welding Qualifications.

FIGURE CODING FOR EXPANDING GATE VALVES

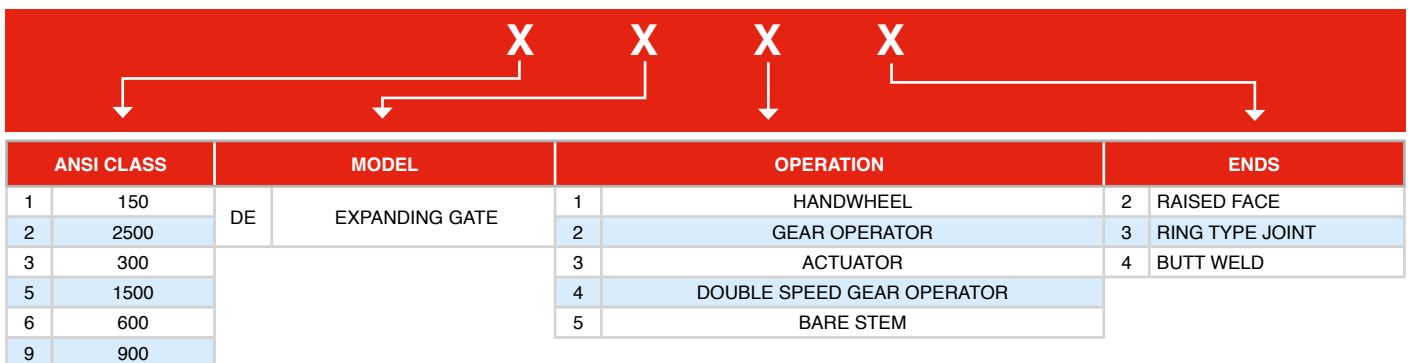

EXAMPLES	
1DE12	Expanding Gate, class 150, Handwheel operated, Raised Face ends
3DE23	Expanding Gate, class 300, Gear Operator, Ring Type Joint ends
6DE42	Expanding Gate, class 600, Double Speed Gear Operator, Raised Face ends

HOW TO ORDER

WALWORTH valves are designed by a catalog figure number which describes their main characteristics. The valve identification system shown below is intended to assist our Customers in valve specification to avoid mistakes in manufacturing and delivery. This figure number system describes in an easy way size, type of valve and pressure class, type of ends, trim arrangement, base material & special requirements to comply with. Type of operation (handwheel, gear, electric, pneumatic, etc) must be specified in the purchase order.

10"-1DE12-ES1-WCB-SP



SIZE (INCH)	TYPE OF VALVE & PRESSURE CLASS	TRIM ARRANGEMENTS	BASE MATERIAL ASTM
2"	1DE12=EXP. GATE 150# RF HWO	SOFT SEAT TRIMS:	CARBON STEELS:
2 1/2"	1DE13= EXP. GATE 150# RTJ HWO	ES1=A105+ENP+4140+ENP	A216-WCB (C-Si)
3"	1DE14= EXP. GATE 150# WE HWO	ES2=SS-410+ENP+SS-410	A216-WCC (C-Si)
4"	1DE22= EXP. GATE 150# RF GO	ES3=A105+ENP+17-4PH	LOW TEMPERATURE SERVICE CARBON STEELS:
5"	1DE23= EXP. GATE 150# RTJ GO	METAL TO METAL SEATS:	ASTM A352-LCB (0.03%C-0.6Si-1% MN)
6"	1DE24= EXP. GATE 150# WE GO	EM1=A105+TC+SS-410	ASTM A352-LCC (0.025%-0.6% Si-1% MN)
8"	3DE12= EXP. GATE 300# RF HWO	EM2=SS-410+TC+SS-410	LOW TEMPERATURE SERVICE LOW ALLOY STEELS:
10"	3DE13= EXP. GATE 300# RTJ HWO	EM3=A105+ST+SS-410	A352-LC2 (0.25%C-2.5%Ni-0.65%Mn)
12"	3DE14= EXP. GATE 300# WE HWO	EM4=SS-410+ST+SS-410	A352-LC3 (0.25%C-2.5%Ni-0.65%Mn)
14"	3DE22= EXP. GATE 300# RF GO	EM5=A105+CC+SS-410	NOTE: ADDITIONAL BASE MATERIALS ARE AVAILABLE UPON REQUEST
16"	3DE23= EXP. GATE 300# RTJ GO	EM6=SS-410+CC+SS-410	
18"	3DE24= EXP. GATE 300# WE GO		SUPPLEMENTARY REQUIREMENTS:
20"	3DE12= EXP. GATE 600# RF HWO	NOTE:	GO=Gear Operator
22"	3DE13=EXP. GATE 600# RTJ HWO	TC= TUNGSTEN CARBIDE COATING	CW= Chainwheel Operator
24"	6DE14= EXP. GATE 600# WE HWO	ST= STELLITE COATING (2D, 21 or 6)	BS= Bare Stem prepared for actuator
28"	6DE22= EXP. GATE 600# RF GO	CC=CHROMIUM CARBIDE COATING	MOV= Motor operated valve
30"	6DE23= EXP. GATE 600# RTJ GO		POV= Pneumatic Operated Valve
36"	6DE24= EXP. GATE 600# WE GO		LD= Locking device
42"	9DE12= EXP. GATE 900# RF HWO		NACEMR-01-03 OR NACE MR-01-75
48"	9DE13= EXP. GATE 900# RTJ HWO		SP= Special Paint
	9DE14= EXP. GATE 900# WE HWO		SG= Special Gasket
	9DE22=EXP. GATE 900# RF GO		SPK= Special packing
	9DE23= EXP. GATE 900# RTJ GO		BP= By-pass
	9DE24= EXP. GATE 900# WE GO		SE= Stem Extensions
	5DE12= EXP. GATE 1500# RF HWO		FS= Floor Stands
	5DE13= EXP. GATE 1500# RTJ HWO		TR= Thermal relief fixture
	5DE14= EXP. GATE 1500# WE HWO		PR= Pressure relief fixture
	5DE22= EXP. GATE 1500# RF GO		XX= Additions requirements.
	5DE23= EXP. GATE 1500# RTJ GO		
	5DE24= EXP. GATE 1500# WE GO		

NOTE: ADDITIONAL BASE MATERIALS AND TRIM ARRANGEMENTS ARE AVAILABLE UPON REQUEST

THE WALWORTH COMPANY GENERAL TERMS AND CONDITIONS

ACCEPTANCE: All quotations are for acceptance within 30 days from date of quotation unless extended in writing. In the event a purchase order is placed after this period of time, the WALWORTH Company reserves the right to requote base prices of all valves offered. All orders and contracts are subject to credit approval and acceptance by the WALWORTH Company.

FREIGHT: When prices are f.o.b. point of shipment - no freight allowance - we will attempt to route shipments in the method which will result in the lowest cost unless otherwise instructed. All shipments will be freight charges collect except when stipulated on the purchase order, in which case you will be invoiced for all transportation charges. Delivery of material to a common carrier shall be considered to be delivery to Buyer and shall be at Buyer's risk thereafter. Claims of loss of or damage to material in transit shall be filed by the Buyer directly with the carrier.

PRICES: There will be added to all prices quoted sales, use, occupation or any other excise or similar tax which Seller may be required to pay or collect on or in connection with the sale. Seller shall be established by Federal, State or other government regulation with respect to the product(s) topped by the order which shall be lower than the price(s) specified in the order.

ESCALATION TERMS: Prices shown in this price schedule reflect the costs in effect at the time of publication. These prices will remain firm on all products with a quoted delivery of twenty-six (26) weeks or less. On products which have a scheduled delivery of more than twenty-six (26) weeks, the goods will be invoiced based on the applicable price sheet in effect at the time of shipment. In no event will the invoiced price be less than the price originally quoted.

PURCHASED COMPONENTS: (i.e. motors, gearing, etc.) Prices are quoted on the supplier's price in effect at the time of quotation. Actual invoice price will be adjusted in accordance with the supplier's escalation policy.

DIFFERED SHIPMENTS: If for any reason the customer desires to delay shipments more than 30 days after manufacturing is complete, or to place a on hold or stop to the order during the manufacturing cycle, The WALWORTH Company reserves the right to consider the order cancelled and to invoke cancellation charges per the schedule below.

CANCELLATION: After order acceptance by WALWORTH, items or completed orders may be cancelled and Buyer will be charged for work performed, based on the following schedule:

- Five percent (5%) of prices of stock items.
- Ten percent (10%) of price of stock items ordered in quantities which exceed normal inventory levels.
- Five percent (5%) of prices prior to drawing submittal on made-to-order items.
- 15% after drawing approval, but prior to the start of castings.
- 30% to 50% during casting cycle, depending on the state of completion.
- 55% to 75% during machining and assembly operations, depending on the state of completion.
- 100% after final assembly and test.

REMITTANCES: Remittances must be made to the address indicated on the invoice.

CREDIT TERMS: As quoted. Invoices on balances overdue will be subject to a service charge of 1 1/2 % per month on such indebtedness.

DELIVERIES: Shipments and deliveries shall at all times be subject to the approval of Seller's Credit Department. If the Buyer shall fail to make any

payments according to the terms of the contract, Seller may, in addition to and not in limitation of its other rights and remedies, at its option, cancel all or any part of Buyer's incomplete contracts with Seller, or may defer shipments of deliveries under Buyer's contracts with Seller except upon receipt of satisfactory security or for cash shipment.

All schedule of shipments are estimated as closely as possible and Seller will use its best efforts to ship within the time scheduled, but does not guarantee to do so. Schedules commence with the date Seller receives authorization to proceed with the order, subject to the provisions of the next sentence. The order will not be released for manufacture until complete specifications and approved drawings (if drawing approval is required) are received at the plant of manufacturer and the estimated schedule of shipment will commence with the date of such receipt.

Seller shall not be liable for any direct, indirect or consequential damage or loss caused by any delay in delivery, regardless of the cause of delay.

Without limiting the generality of the foregoing, Seller assumes no responsibility for delays in delivery resulting from fire, flood, accidents, riots, strikes, transportation delays, labor or material shortages, existing or future laws, acts of any governmental authority, or any other cause beyond Seller's control. Items offered from stock are subject to prior sale.

INSPECTION: Final inspection and acceptance of products must be made at the plant of manufacture, unless otherwise provided in the order and/ or in agreed upon specifications. Prices do not include charges for special tests or inspections performed at the request of the Buyer, unless called for in the order and/or in agreed upon specifications.

RETURNS: Permission in writing and return tagging instructions must be obtained from Seller before any goods returned for credit or adjustment will be accepted. Where returned goods are accepted, a minimum charge of 25% of the invoice price will be made, plus freight from both directions and costs of reconditioning the material for resale as new.

WARRANTY: Seller will replace without charge or refund the purchase price of products manufactured by Seller which prove to be defective in the material or workmanship, provided in each case that the product is properly installed and is used in the service for which Seller recommends it and that a written claim, specifying the alleged defect, is presented to Seller. Seller shall in no event be responsible for (a) claims for labor, expenses or other damages occasioned by defective products or (b) for consequences or secondary damages. THE WARRANTY STATED IN THIS PARAGRAPH IS IN LIEU OF ALL OTHER WARRANTIES, EITHER EXPRESSED OR IMPLIED. WITH RESPECT TO WARRANTIES, THIS PARAGRAPH STATES BUYER'S EXCLUSIVE REMEDY AND SELLER'S EXCLUSIVE LIABILITY.

DESIGN, ETC: Seller reserves the right to change design, materials or specifications without notice. There will be a charge for modifying an order after it has been entered when such change or modification results in additional engineering or clerical work for either The WALWORTH Company or our suppliers.

MINIMUM CHARGE: Orders totaling less than \$100.00 net will be billed at a minimum charge of \$100.00. Repair parts will be billed at a minimum charge of \$50.00.

NOTE: We reserve the right to correct obvious clerical errors in quotations, invoices, and other contracts.



WALWORTH®

Since 1842



www.walworth.com

MÉXICO

Industrial de Válvulas, S.A. de C.V.

Industria Lote 16 Sin Número, Fracc. Industrial El Trébol De Tepetzotlán, Tepetzotlán Estado de México C.P. 54610
Phone: (52 55) 5899 1700 Fax: (52 55) 5876 0156 | e-mail: info@walworth.com.mx

USA/CAN AUTHORIZED DISTRIBUTOR

TWC The Valve Company

13641 Dublin Court, Stafford, Texas 77477 | Phone: (281) 566 1200 Fax: (281) 566 1299 |
www.twcvalves.com | e-mail: info@twcousa.com



Scan me with your smartphone to get more info about **WALWORTH** valves

