

# PRODUCT SPECIFICATION DRAWING

## QUICK STRAP® #QS-120

### Seismic support for water heaters

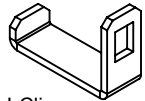
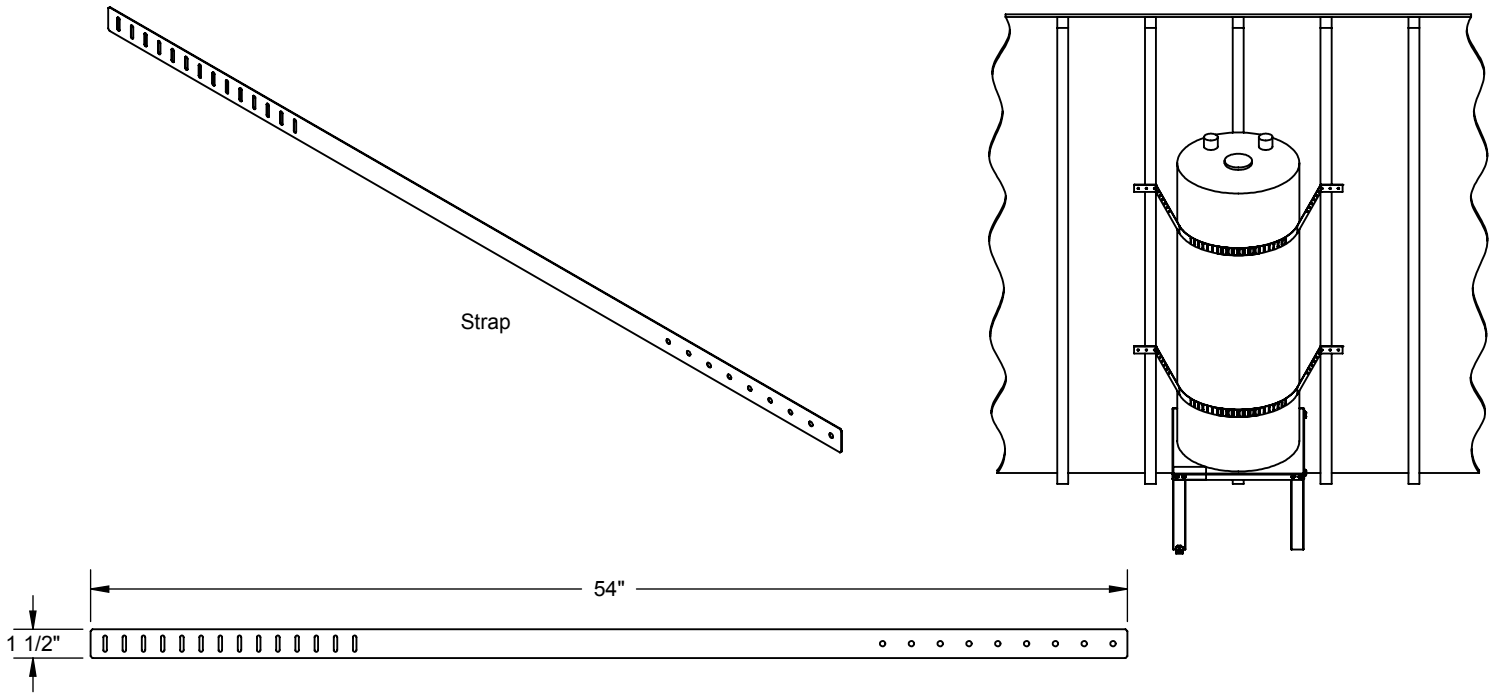

J-Clip



Carriage Bolt, #3/8-16 x 3.0" long



3/8" Hex Nut

ALL DIMENSIONS IN INCHES

**The QUICK STRAP® #QS-120 is a seismic/earthquake support system for water heaters up to 120 U.S. gallons in size. The system includes: (4) Straps, (2) J-Clips, (2) 3/8" Carriage Bolts and (2) 3/8" Hex Nuts. The Quick Link® system allows for full adjustment from the front side of the water heater.**

#### Product Information:

- Material: Strap, 24 gage CRS, galvanized
- California Division State Architect (DSA) approval #98-018
- UPC / IPC / IAPMO listed



THIS INFORMATION IS PROPRIETARY TO HOLDRITE AND IS SUBJECT TO CHANGE WITHOUT NOTICE. IT MAY NOT BE REPRODUCED IN PART OR WHOLE WITHOUT WRITTEN AUTHORIZATION.



CONVERTING MAKESHIFT METHODS INTO ENGINEERED SOLUTIONS<sup>SM</sup>  
 800-321-0316 OR 760-744-6944 / FAX: 760-744-0507 / WWW.HOLDRITE.COM  
 spec\_QS-120\_Rev1

Product Submittal	
Job Name:	
Date:	
Part Number:	Qty:
Architect / Owner:	
Contractor:	
Notes:	