



115V 12,000 BTU/H WALL MOUNTED HEAT PUMP SYSTEM

SUBMITTAL COVER SHEET

PROJECT NAME _____

LOCATION _____



ARCHITECT _____

ENGINEER _____

CONTRACTOR _____

REFERENCE _____

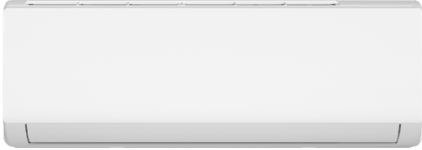
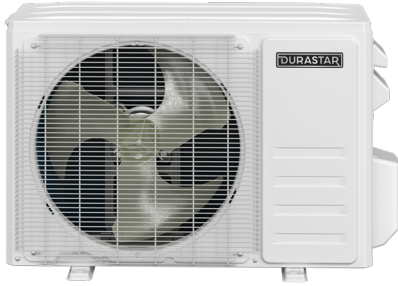
SUBMITTED BY _____ DATE _____

Indoor Unit (IDU): DREW12S2AL	Outdoor Unit (ODU): DRE1U12S2A	Wireless Remote Control
		

PRODUCT FEATURES

- Variable Speed Inverter Compressor
- Quiet Operations
- 115V compatibility for standard household power
- Operation down to -4°F in heating and up to 122°F in cooling
- Turbo, ECO, Self Clean, Timer, Sleep modes and more
- 4-Way fan position coverage (up to 72 angles)
- 46°F freeze protection
- Anti-corrosive fin coating on both the indoor and outdoor

CAPACITIES		
Cooling Capacity (BTU/hr)	Rated at 95°F (35°C) ¹	12000
	at 5° (-15°C)	11900
	Cooling Range	3400-13000
Heating Capacity (BTU/hr)	Rated at 47°F (8°C) ²	12000
	Rated at 17°F (-8°C) ³	10000
	Rated at 5° (-15°C) ⁴	9000
	at -4°F (-20°C)	7200
	Heating Range	3400-13900

SYSTEM DATA	
Refrigerant Type	R-454B
Refrigerant Charge (oz. (kg))	30.34 (0.860)
Design Pressure (PSIG)	725
Indoor/ Outdoor Coil Coating	Blue Fin Coating

EFFICIENCY DATA	
SEER2	20
EER2	10.5
HSPF2	9.5
COP at 47°F (8°C) ²	3.41
COP at 5°F (-15°C) ⁴	1.80





115V 12,000 BTU/H WALL MOUNTED HEAT PUMP SYSTEM

SPECIFICATIONS

LINE SET REQUIREMENTS	
Connection Type	Flare
Liquid (in. (mm))	Ø1/4 (Ø6.35)
Gas (in. (mm))	Ø3/8 (Ø9.52)
Pre-Charge Length (ft. (m))	25 (7.5)
Minimum Length (ft. (m))	10 (3.0)
Maximum Length (ft. (m))	49 (15.0)
Maximum Height Differential (ft. (m))	33 (10.0)
Additional Refrigerant (oz./ft (g/m))	0.11 (10.0)

OUTDOOR UNIT		
Unit Dimensions (in. (mm))	Width	31 (787)
	Depth	11-7/16 (290)
	Height	19-5/8 (498)
Carton Dimensions (in. (mm))	Width	32-1/16 (818)
	Depth	12-13/16 (325)
	Height	20-1/4 (515)
Net Weight (lbs. (kg))	59.5 (27)	
Gross Weight (lbs. (kg))	66.1 (30)	
Cooling Operating Temp. (°F (°C))	5 - 122 (-15 - 50)	
Heating Operating Temp. (°F (°C))	-4 - 86 (-20 - 30)	
Voltage/Phase/Frequency	115V, 1 Phase, 60 Hz	
Voltage Range	105-125V	
Recommended Breaker (Amps)	25	
Minimum Circuit Ampacity (Amps)	17	
Communication Wire Size	14*4 AWG Stranded	
Rated Current - Cooling (Amps) ¹	9.5	
Rated Current - Heating (Amps) ²	9.3	
Sound Pressure (dB(A))	55	

INDOOR UNIT		
Unit Dimensions (in. (mm))	Width	31-15/16 (811)
	Depth	8 (203)
	Height	11-1/2 (292)
Carton Dimensions (in. (mm))	Width	34-13/16 (885)
	Depth	10-13/16 (275)
	Height	14-7/16 (366)
Net Weight (lbs. (kg))	19.8 (9.0)	
Gross Weight (lbs. (kg))	26.5 (12.0)	
Indoor Unit Air Flow (CFM (m ³ /h))	Low	200 (300)
	Medium	235 (380)
	High	270 (450)
	Turbo	342 (520)
Moisture Removal (Pints/day (L/h))	81.15 (1.6)	
Drain Port O.D. (in. (mm))	Ø5/8 (Ø16)	
Recommended Breaker (Amps)	15	
Minimum Circuit Ampacity (Amps)	17	
Sound Pressure (dB(A))	Silent	28
	Low	30
	Medium	35
	High	42
	Turbo	45

COMPRESSOR	
Type	Rotary Inverter
Oil Type	Ester Oil VG74
Oil Charge (oz. (ml))	6.08 (280)

¹ Value at AHRI Rated Capacity at 95°F (35°C) (AFull)
² Value at AHRI Rated Capacity at 47°F (8°C) (H1Full)
³ Value at AHRI Rated Capacity at 17°F (-8°C) (H32)
⁴ Value at AHRI Rated Capacity at 5°F (-15°C) (H42)



115V 12,000 BTU/H WALL MOUNTED HEAT PUMP SYSTEM

UNIT DIMENSIONS

INDOOR UNIT

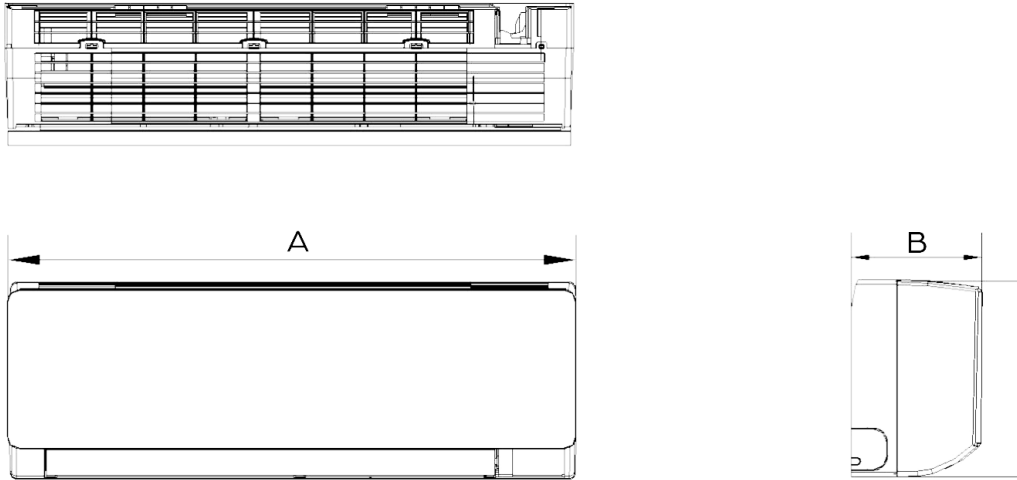

OUTDOOR UNIT

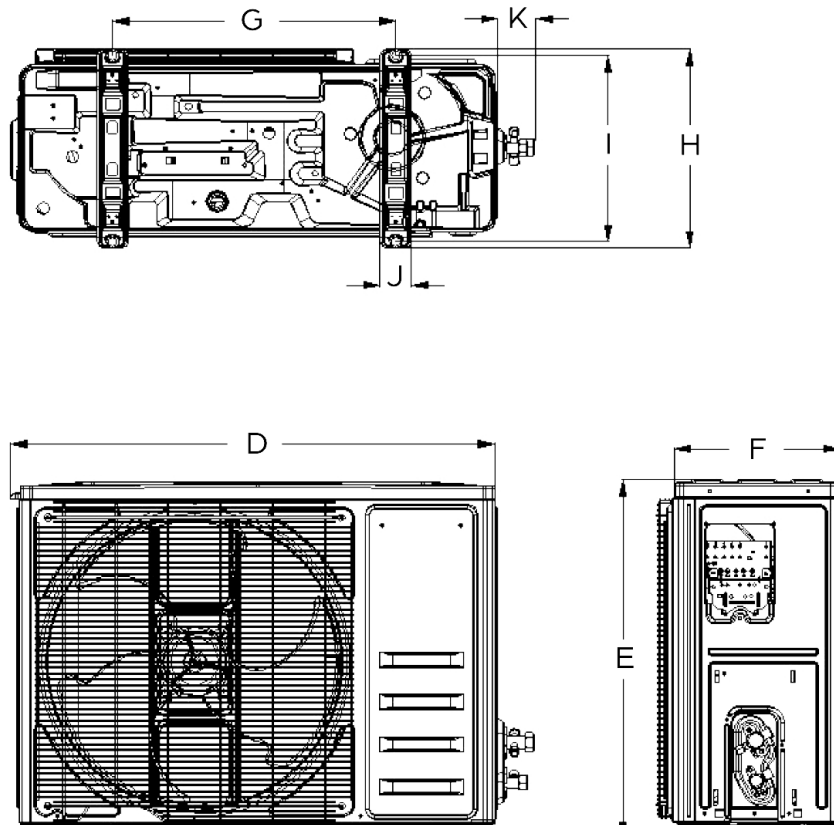

Model	Indoor Unit (inch (mm))			Outdoor Unit (inch (mm))							
	A	B	C	D	E	F	G	H	I	J	K
DREW09S2AL / DRE1U09S2A	31.93 (811)	11.50 (292)	7.95 (202)	28.03 (712)	19.61 (498)	9.21 (234)	16.34 (415)	11.43 (290.4)	10.35 (263)	1.89 (48)	2.2 (55.9)



115V 12,000 BTU/H WALL MOUNTED HEAT PUMP SYSTEM

CLEARANCE

