

“ML” Oil Pump

**NOTE: Order parts by Catalog Number only.
DO NOT order by Reference Number.**

Ref. No.	Catalog No.	Description
—†	27307	“ML” Oil Pump
1	33442	Pump Valve Body
2	33432	Compression Fitting (2)
3*	33457	Gasket (Set of 2)
4*	33452	Valve Retainer Assy.
5	33482	Gerotor Housing w/Bearing
6*	33477	O-Ring
7†	33462	Sleeve Bearing
8	33467	Gerotor Set
9	33447	Pump Cap w/Seal
10*	33472	Oil Seal
11	44510	Soc. Hd. Cap Screw 1/4" - 20 x 2"
12	45150	Lock Washer 1/4"
*	33422	“ML” Service Kit

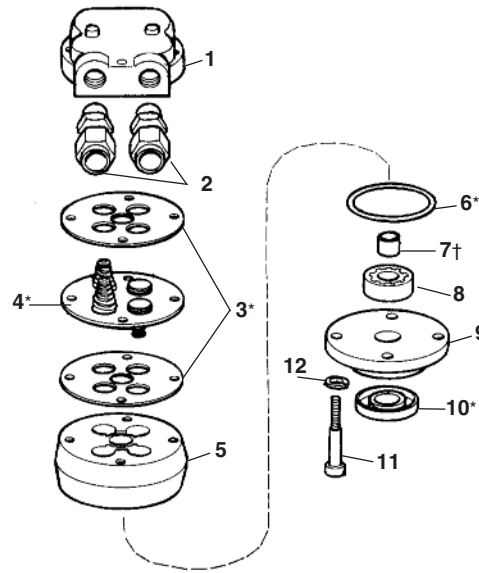

Note: Ref. 7 Sleeve Bearing used on older Gerotor Housings, not required on new pumps.
* Indicates Part is Included in Service Kit.
† See Service Note

No. 764 Pipe Cutter

Ref. No.	Catalog No.	Description
—	26212	764 Pipe Cutter
1	26752	Screw Handle
2	41730	Ball Bearing
3	26742	Cutter Frame
4	26747	Roll Housing
5	26757	Groove Pin
6	26762	Groove Pin (2)
7	33125	Cutter Wheel
8	34785	Roll (2)
9	26252	Roll F/Coated Pipe (2 per set)
9	34790	Wheel Pin
10	27072	Groove Pin

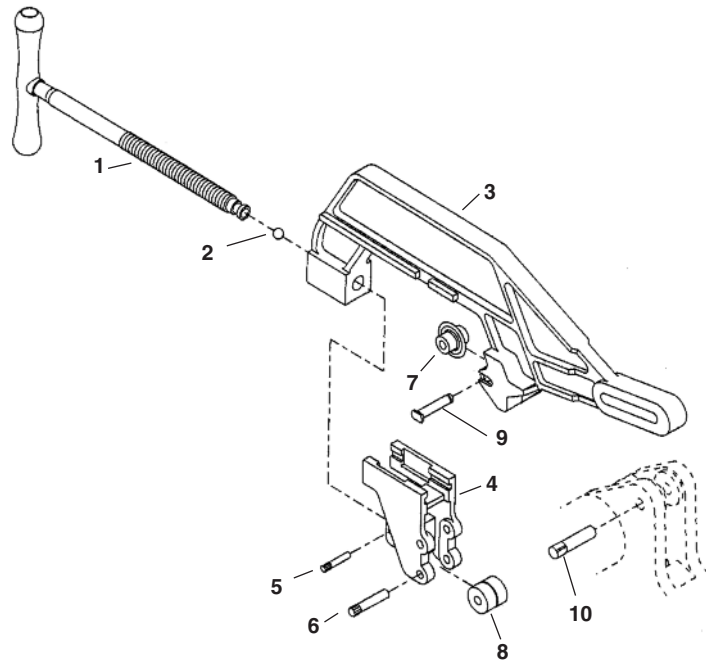

No. 744 Reamer Assembly

Ref. No.	Catalog No.	Description
—	26217	744 Reamer Assembly
1	26602	Reamer Arm
2	34577	Reamer Blade 1/4" - 4"
3	27037	Shoulder Bolt
4	27072	Groove Pin
5	26607	Pivot Block
6	26727	Groove Pin (2)

