

## SPECIFICATIONS

# FIGURE 16B-200

## STAINLESS STEEL CHECK VALVE



### 200 CWP SWING CHECK VALVE

#### FEATURES

- 200 CWP
- Temperature: -4°F to 356°F
- Investment cast components
- Stainless steel body and trim
- Solid one-piece disc
- Threaded NPT ends
- Manufactured silicone free  
*Manufactured, assembled and tested without the use of silicone-bearing compounds or lubricants*

#### STANDARDS

- Material: ASTM/ASME A351 Gr. CF8M
- Connections: ANSI B1.20.1 (NPT)



#### FIGURE NUMBER MATRIX

Size Code – FNW 16B 200	
1/4	B
3/8	C
1/2	D
3/4	F
1	G
1-1/4	H
1-1/2	J
2	K

#### CV & WEIGHTS

Size	Cv	Wt. (lbs.)
1/4	3.2	1.2
3/8	7.5	1.1
1/2	9.0	1.0
3/4	16.6	1.7
1	27.0	2.1
1-1/4	45.0	3.2
1-1/2	72.4	4.4
2	118.9	6.0

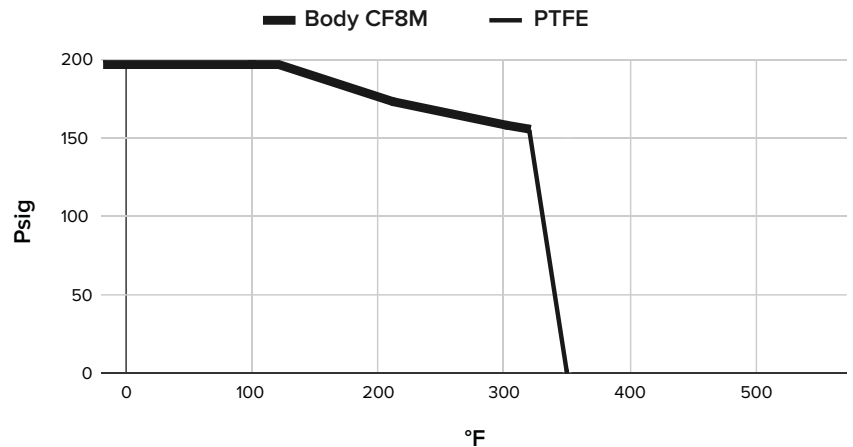

SPECIFICATIONS

**FIGURE 16B-200**  
STAINLESS STEEL CHECK VALVE



200 CWP SWING CHECK VALVE

PARTS DIAGRAM

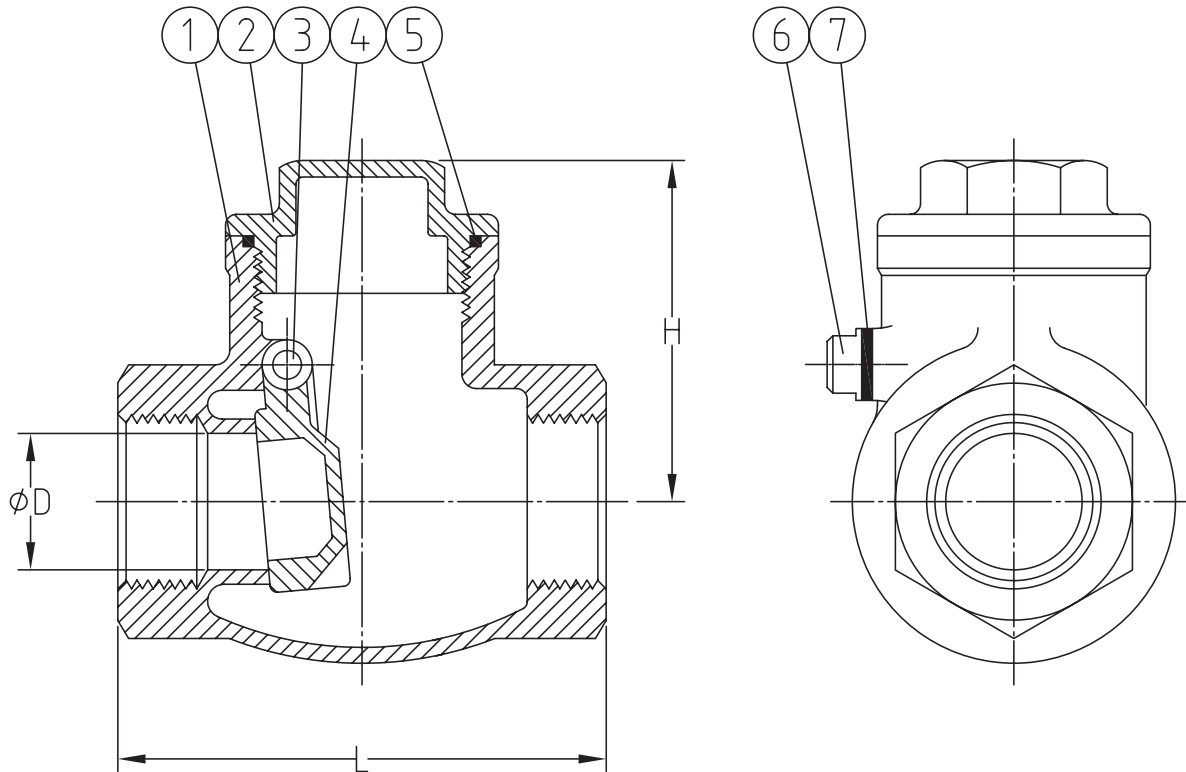

DIMENSIONS (INCHES)

Size	ØD	L	H
1/4	0.44	2.56	1.65
3/8	0.51	2.56	1.65
1/2	0.59	2.56	1.65
3/4	0.79	3.15	2.01
1	0.98	3.54	2.36
1-1/4	1.26	4.13	2.60
1-1/2	1.57	4.72	2.95
2	1.97	5.51	3.15

PART MATERIALS & QUANTITY

Ref. No.	Description	Material	Qty
1	Body	ASTM A351 Gr. CF8M	1
2	Cap	ASTM A351 Gr. CF8M	1
3	Hanger Pin	316SS	1
4	Disc	ASTM A351 Gr. CF8M	1
5	Body Seal	PTFE	1
6	Plug	316SS	1
7	Plug Gasket	PTFE	1