

FIGURE 17B-200

STAINLESS STEEL GLOBE VALVE



200 CWP RISING STEM GLOBE VALVE

FEATURES

- 200 CWP
- Rising stem
- Inside screw
- Temperature: -4°F to 356°F
- Investment cast components
- Stainless steel body and trim
- Conical seat design
- Threaded NPT ends
- Adjustable packing

STANDARDS

- Material: ASTM A351 Gr. CF8M
- Connections: ANSI B1.20.1 (NPT)

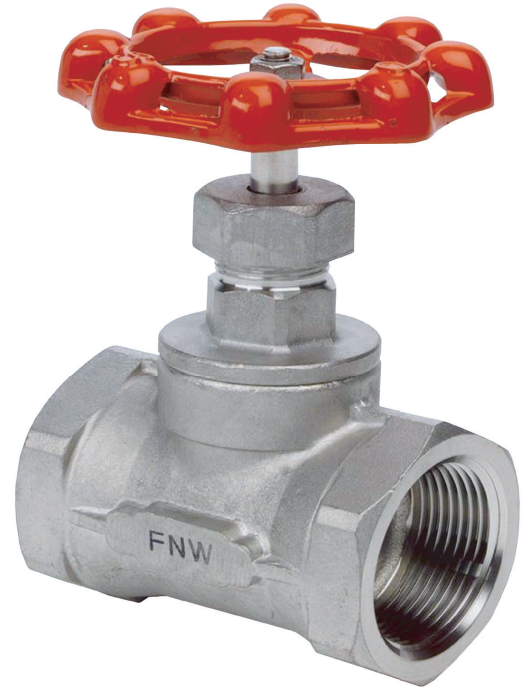

FIGURE NUMBER MATRIX

Size Code – FNW 17B 200	
1/2	D
3/4	F
1	G
1-1/4	H
1-1/2	J
2	K

CV & WEIGHTS

Size	Cv	Wt. (lbs)
1/2	2.2	2.2
3/4	3.6	3.6
1	6.6	6.6
1-1/4	10.6	10.6
1-1/2	17.8	17.8
2	29.2	29.2

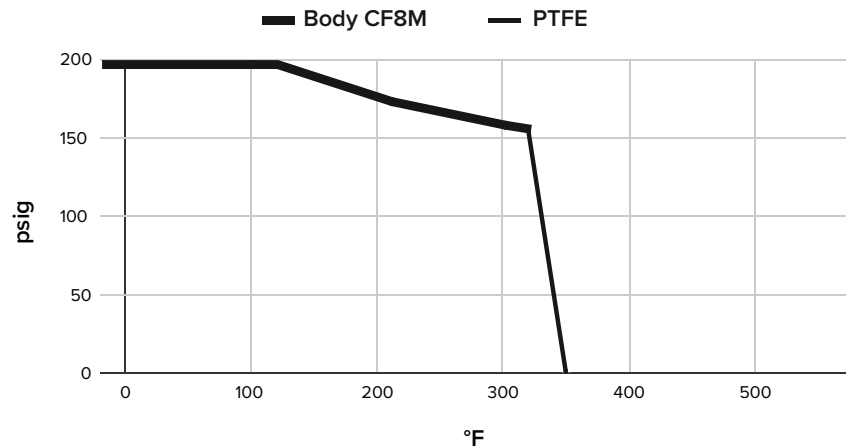

FIGURE 17B-200

STAINLESS STEEL GLOBE VALVE



200 CWP RISING STEM GLOBE VALVE

PARTS DIAGRAM

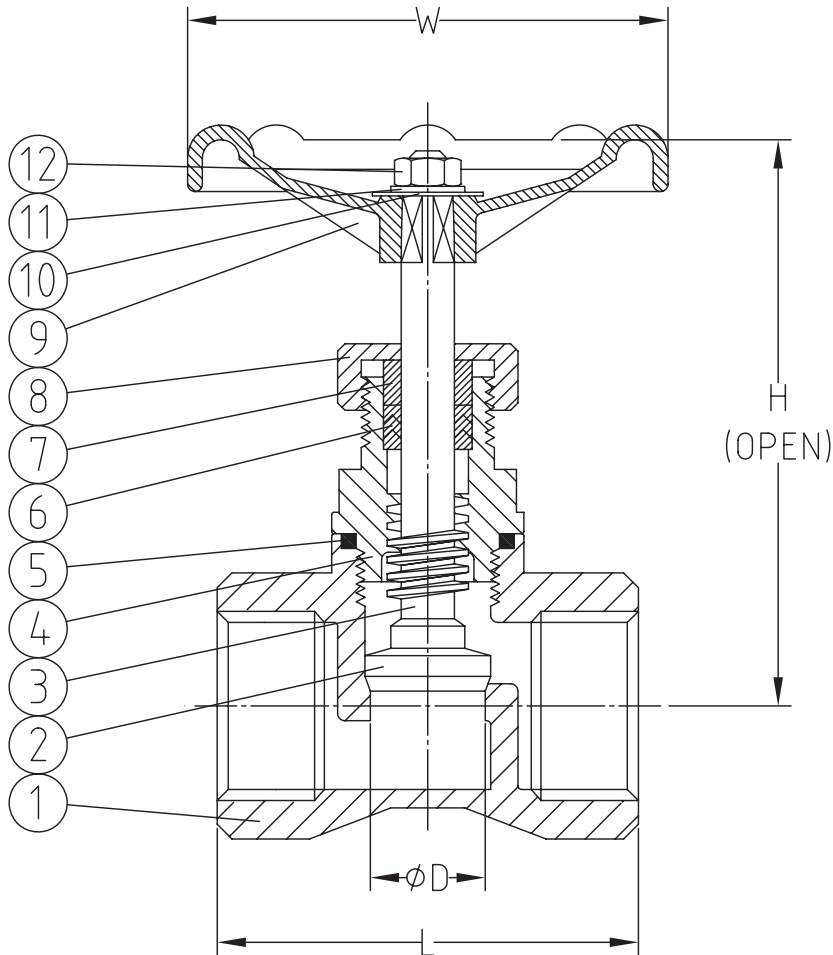

DIMENSIONS (INCHES)

Size	ØD	L	H	W
1/2	0.47	2.05	3.11	2.76
3/4	0.59	2.36	3.58	2.76
1	0.79	2.88	4.13	3.15
1-1/4	0.98	3.19	5.00	3.15
1-1/2	1.26	3.54	5.59	3.54
2	1.57	3.98	6.22	3.94

PART MATERIALS & QUANTITY

Ref. No.	Description	Material	Qty
1	Body	ASTM A351 Gr. CF8M	1
2	Disc	316SS	1
3	Stem	316SS	1
4	Bonnet	ASTM A351 Gr. CF8M	1
5	Body Seal	PTFE	1
6	Stem Packing	PTFE	1 Set
7	Gland	304SS	1
8	Gland Nut	ASTM A351 Gr. CF8M	1
9	Hand Wheel	DIE CAST ALUMINUM	1
10	Name Plate	ALUMINUM	1
11	Hand Wheel Washer	304SS	1
12	Hand Wheel Nut	304SS	1