

D



**JAY R. SMITH MFG. CO.**  
 DIVISION OF SMITH INDUSTRIES, INC.  
 POST OFFICE BOX 3237  
 MONTGOMERY, ALABAMA 36109-0237 (USA)  
 TEL: 334-277-8520 FAX: 334-272-7396 www.jrsmith.com



MEMBER OF:

LOCATION

# LAVATORY SUPPORTS WITH CONCEALED ARMS

## WALL MOUNTED

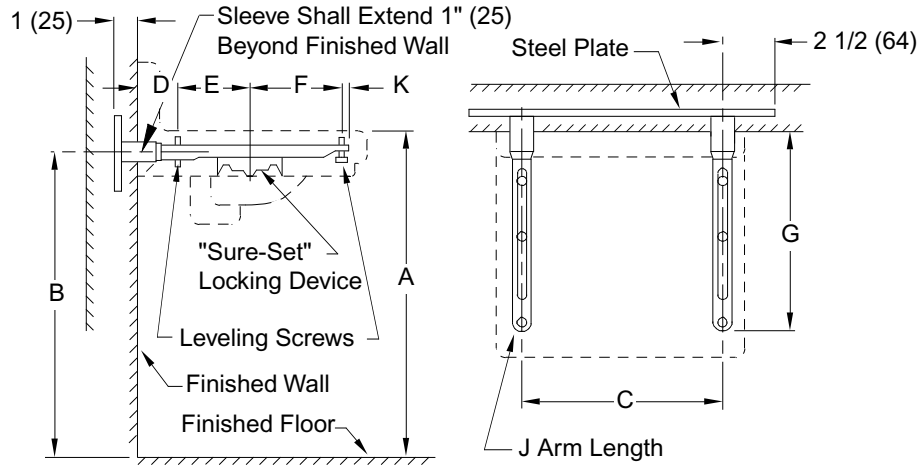

**Fig. 0722 ... FOR HIGH BACK LAVATORIES SET ON STEEL PLATE SECURED IN WALL**

### ROUGHING-IN TABLE

FIXTURE NAME				NUMBER			SIZE	
A	B	C	D	E	F	G	J	K

**NOTE:** The rough-in dimensions listed on this drawing are based on current information available to Jay R. Smith by the fixture manufacturers. We recommend that you verify these dimensions with the fixture manufacturer. We will not accept responsibility for rough-in dimension changes by the fixture manufacturer.

**NOTE:** Dimensions shown in parentheses are in millimeters.

DRAWING NUMBER  
S0722 (B)

SIZE  
A

SCALE:  
NONE

DATE:  
10-9-69

APPROVED BY:

CHECKED BY:  
BH

DRAWN BY:  
RVB

0722

WE CAN ASSUME NO RESPONSIBILITY FOR USE OF SUPERSEDED OR VOID DATA  
DIMENSIONS ARE SUBJECT TO MANUFACTURERS TOLERANCE AND CHANGE WITHOUT NOTICE

D	4-2-97	Added Millimeters	EMB	BS
C	6-22-94	Revised	EMB	BS
B	8-10-93	Submittal Update	EMB	BS
REV.	DATE	DESCRIPTION	BY	CKD. BY

WEIGHT POUNDS	VOLUME CUBIC FEET

**FIGURE NUMBER**  
**0722**