

ProPEX® Engineered Plastic (EP) Tee

Submittal Information

Revision B: Sept. 18, 2008

Project Information

Job Name:

Location:

Part No. Ordered:

Engineer:

Date Submitted:

Contractor:

Submitted By:

Manufacturer's Representative:

Approved By:

Technical Data

Material: UDEL® Polysulfone, 20% Glass-reinforced (½" to 1")
Acudel® Modified Polyphenylsulfone (1¼" to 1½")
Radel® Polyphenylsulfone (2")

Maximum Temperature (no pressure): 320°F (160°C)

Maximum Working Temperature/Pressure: 210°F (99°C) at 150 psi

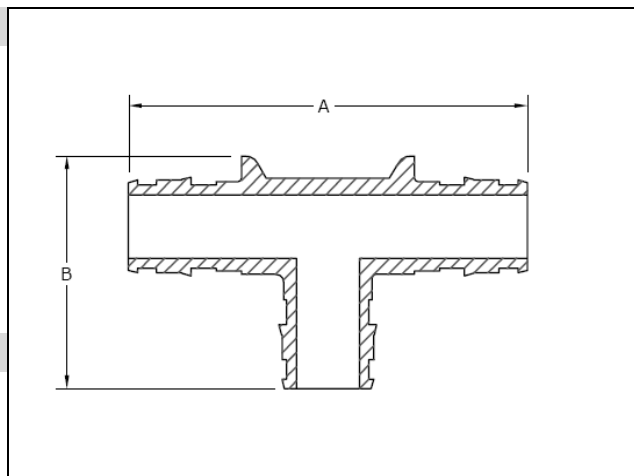

Product Information and Application Use

ProPEX® Engineered Plastic (EP) Tee makes diverting connections for Uponor PEX tubing in supply and return mains.¹

Note: Branch size is listed last in the following part descriptions.

✓ Description	Part Number	A	B	Weight
ProPEX EP Tee, ½" PEX x ½" PEX x ½" PEX	Q4755050	2.50"	1.53"	0.02 lbs.
ProPEX EP Tee, ¾" PEX x ¾" PEX x ¾" PEX	Q4757575	3.30"	1.94"	0.05 lbs.
ProPEX EP Tee, 1" PEX x 1" PEX x 1" PEX	Q4751010	4.10"	2.47"	0.07 lbs.
ProPEX EP Tee, 1¼" PEX x 1¼" PEX x 1¼" PEX	Q4751313	4.80"	3.22"	0.15 lbs.
ProPEX EP Tee, 1½" PEX x 1½" PEX x 1½" PEX	Q4751515	5.80"	3.82"	0.25 lbs.
ProPEX EP Tee, 2" PEX x 2" PEX x 2" PEX	Q4752000	7.45"	4.79"	0.38 lbs.

Installation

Use the appropriate ProPEX Ring for PEX tubing. Refer to the AQUAPEX® Professional Plumbing Installation Handbook or Uponor Radiant Installation Handbook for additional information.

Standards

CAN/CSA B137.5; ASTM F877; ASTM F1960

Codes

IPC; UPC; NSPC; NPC of Canada

Listings

IAPMO 3558; ANSI/NSF 14- and 61-certified; HUD MR 1269; ICC ESR 1099

Related Applications

PEX-a Plumbing Systems
Radiant Heating and Cooling Systems

Contact Information

Uponor, Inc.
5925 148th Street West
Apple Valley, MN 55124 USA
Phone: (800) 321-4739
Fax: (952) 891-2008
www.uponor-usa.com

Uponor Ltd.
2000 Argentia Road, Plaza 1, Suite 200
Mississauga, ON L5N 1W1 CANADA
Phone: (888) 994-7726
Fax: (800) 638-9517
www.uponor.ca

¹ProPEX® is a registered trademark of Uponor, Inc. ProPEX™ is a trademark of Uponor Ltd.