

Channel Hole Patterns

B11SH THRU B56SH SH TYPE CHANNEL

• For beam loads use 90% of Channel Loading Chart

Part No.	Thickness		Height H		Weight	
	In.	mm	In.	mm	Lbs./Ft.	kg/m
B11SH	12 Ga.	(2.6)	3 ¹ / ₄ "	(82.5)	2.97	(4.42)
B12SH	12 Ga.	(2.6)	2 ⁷ / ₁₆ "	(61.9)	2.39	(3.55)
B22SH	12 Ga.	(2.6)	1 ⁵ / ₈ "	(41.3)	1.82	(2.71)
B24SH	14 Ga.	(1.9)	1 ⁵ / ₈ "	(41.3)	1.34	(1.99)
B26SH	16 Ga.	(1.5)	1 ⁵ / ₈ "	(41.3)	1.07	(1.59)
B32SH	12 Ga.	(2.6)	1 ³ / ₈ "	(34.9)	1.62	(2.41)
B42SH	12 Ga.	(2.6)	1"	(25.4)	1.36	(2.02)
B52SH	12 Ga.	(2.6)	1 ³ / ₁₆ "	(20.6)	1.19	(1.77)
B54SH	14 Ga.	(1.9)	1 ³ / ₁₆ "	(20.6)	.91	(1.35)
B56SH	16 Ga.	(1.5)	1 ³ / ₁₆ "	(20.6)	.80	(1.19)

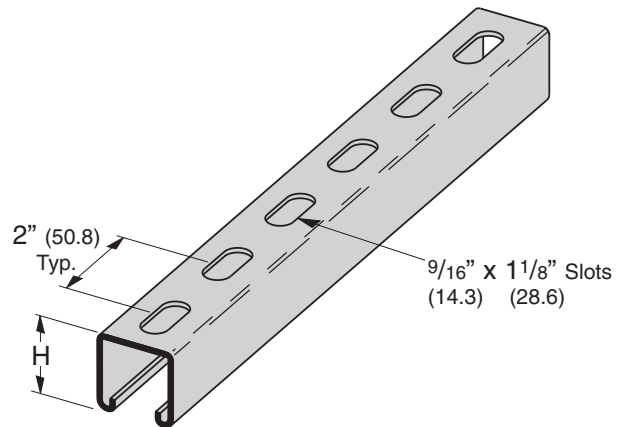

B11S THRU B56S S TYPE CHANNEL

• For beam loads use 90% of Channel Loading Chart

Part No.	Thickness		Height H		Weight	
	In.	mm	In.	mm	Lbs./Ft.	kg/m
B11S	12 Ga.	(2.6)	3 ¹ / ₄ "	(82.5)	2.94	(4.37)
B12S	12 Ga.	(2.6)	2 ⁷ / ₁₆ "	(61.9)	2.36	(3.51)
B22S	12 Ga.	(2.6)	1 ⁵ / ₈ "	(41.3)	1.79	(2.66)
B24S	14 Ga.	(1.9)	1 ⁵ / ₈ "	(41.3)	1.32	(1.96)
B26S	16 Ga.	(1.5)	1 ⁵ / ₈ "	(41.3)	1.06	(1.58)
B32S	12 Ga.	(2.6)	1 ³ / ₈ "	(34.9)	1.59	(2.36)
B42S	12 Ga.	(2.6)	1"	(25.4)	1.33	(1.98)
B52S	12 Ga.	(2.6)	1 ³ / ₁₆ "	(20.6)	1.16	(1.72)
B54S	14 Ga.	(1.9)	1 ³ / ₁₆ "	(20.6)	.89	(1.32)
B56S	16 Ga.	(1.5)	1 ³ / ₁₆ "	(20.6)	.79	(1.17)

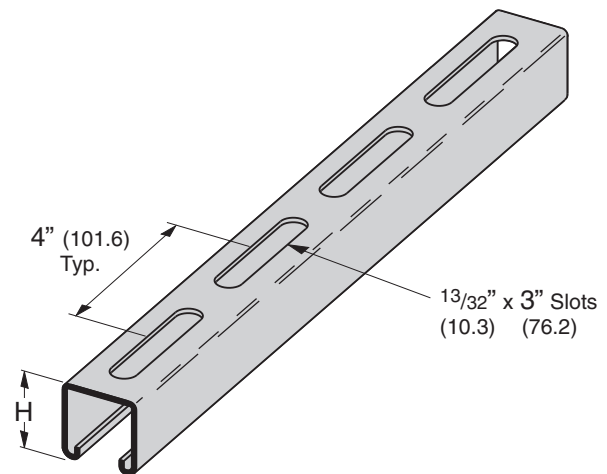

B11H17/8 THRU B56H17/8 H17/8 TYPE CHANNEL

• For beam loads use 90% of Channel Loading Chart

Part No.	Thickness		Height H		Weight	
	In.	mm	In.	mm	Lbs./Ft.	kg/m
B11H17/8	12 Ga.	(2.6)	3 ¹ / ₄ "	(82.5)	3.00	(4.46)
B12H17/8	12 Ga.	(2.6)	2 ⁷ / ₁₆ "	(61.9)	2.42	(3.60)
B22H17/8	12 Ga.	(2.6)	1 ⁵ / ₈ "	(41.3)	1.85	(2.75)
B24H17/8	14 Ga.	(1.9)	1 ⁵ / ₈ "	(41.3)	1.36	(2.02)
B26H17/8	16 Ga.	(1.5)	1 ⁵ / ₈ "	(41.3)	1.09	(1.62)
B32H17/8	12 Ga.	(2.6)	1 ³ / ₈ "	(34.9)	1.65	(2.45)
B42H17/8	12 Ga.	(2.6)	1"	(25.4)	1.39	(2.07)
B52H17/8	12 Ga.	(2.6)	1 ³ / ₁₆ "	(20.6)	1.22	(1.81)
B54H17/8	14 Ga.	(1.9)	1 ³ / ₁₆ "	(20.6)	.93	(1.38)
B56H17/8	16 Ga.	(1.5)	1 ³ / ₁₆ "	(20.6)	.82	(1.22)

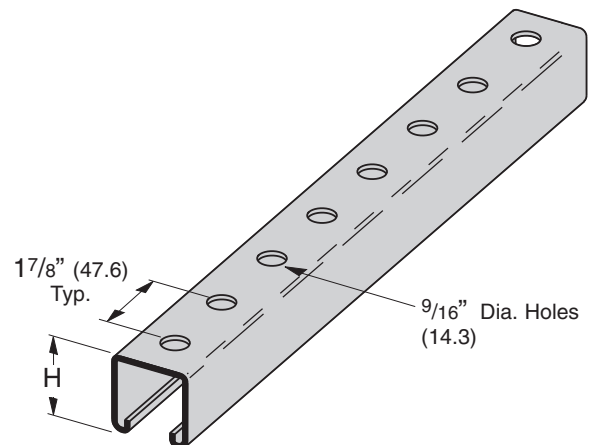

Reference page 14 for general fitting and standard finish specifications.

B22TH (TH TYPE CHANNEL)

• For beam loads use 90% of Channel Loading Chart

Part No.	Thickness		Height H		Weight	
			In.	mm	Lbs./Ft.	kg/m
B22TH	12 Ga.	(2.6)	1 ⁵ / ₈ "	(41.3)	1.76	(2.62)

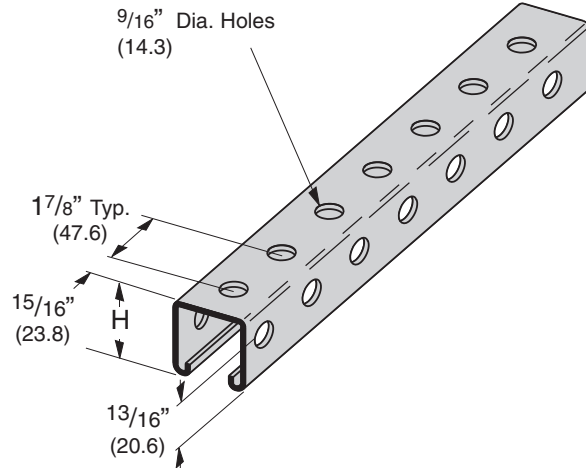

B11KO6 THRU B56KO6 (KO6 TYPE KNOCKOUT CHANNEL)

• For beam loads use 90% of Channel Loading Chart

Part No.	Thickness		Height H		Weight	
			In.	mm	Lbs./Ft.	kg/m
B11KO6	12 Ga.	(2.6)	3 ¹ / ₄ "	(82.5)	3.05	(4.54)
B12KO6	12 Ga.	(2.6)	2 ⁷ / ₁₆ "	(61.9)	2.47	(3.67)
B22KO6	12 Ga.	(2.6)	1 ⁵ / ₈ "	(41.3)	1.90	(2.83)
B24KO6	14 Ga.	(1.9)	1 ⁵ / ₈ "	(41.3)	1.40	(2.08)
B26KO6	16 Ga.	(1.5)	1 ⁵ / ₈ "	(41.3)	1.12	(1.66)
B32KO6	12 Ga.	(2.6)	1 ³ / ₈ "	(34.9)	1.70	(2.53)
B42KO6	12 Ga.	(2.6)	1"	(25.4)	1.44	(2.14)
B52KO6	12 Ga.	(2.6)	1 ³ / ₁₆ "	(20.6)	1.27	(1.89)
B54KO6	14 Ga.	(1.9)	1 ³ / ₁₆ "	(20.6)	.97	(1.44)
B56KO6	16 Ga.	(1.5)	1 ³ / ₁₆ "	(20.6)	.85	(1.26)

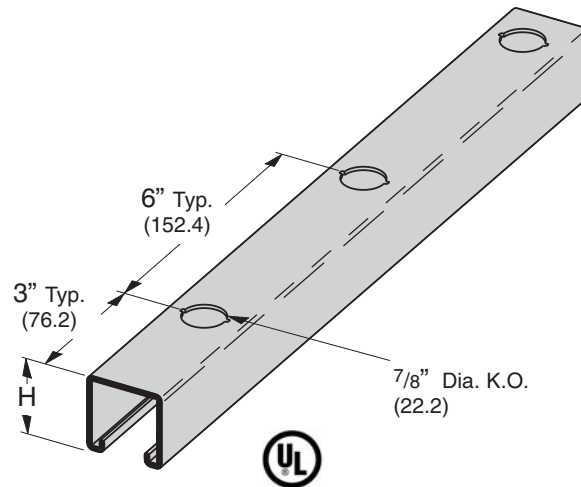

Channel & Combinations

B22SHA (BACK TO BACK SH TYPE CHANNEL)

• For beam loads use 90% of Channel Loading Chart

Part No.	Thickness		Height H		Weight	
			In.	mm	Lbs./Ft.	kg/m
B22SHA	12 Ga.	(2.6)	3 ¹ / ₄ "	(82.5)	3.64	(5.42)

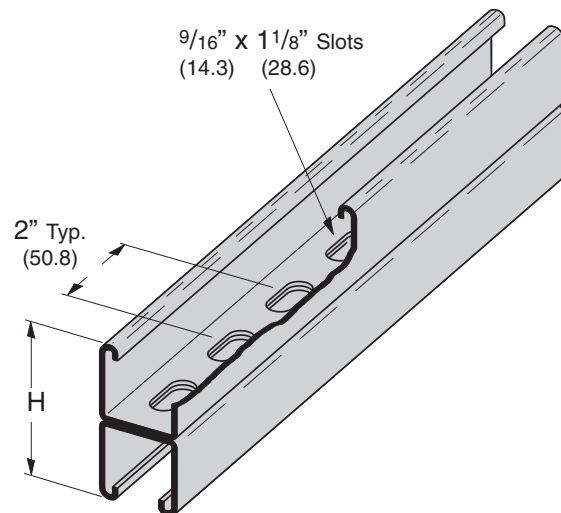

Reference page 14 for general fitting and standard finish specifications.

Channel Hole Patterns

B11S58 THRU B56S58 S58 TYPE CHANNEL

• For beam loads use 90% of Channel Loading Chart

Part No.	Thickness		Height H		Weight	
	In.	mm	In.	mm	Lbs./Ft.	kg/m
B11S58	12 Ga.	(2.6)	3 ¹ / ₄ "	(82.5)	2.94	(4.37)
B12S58	12 Ga.	(2.6)	27 ¹ / ₁₆ "	(61.9)	2.36	(3.51)
B22S58	12 Ga.	(2.6)	1 ⁵ / ₈ "	(41.3)	1.79	(2.66)
B24S58	14 Ga.	(1.9)	1 ⁵ / ₈ "	(41.3)	1.32	(1.96)
B26S58	16 Ga.	(1.5)	1 ⁵ / ₈ "	(41.3)	1.06	(1.58)
B32S58	12 Ga.	(2.6)	1 ³ / ₈ "	(34.9)	1.59	(2.36)
B42S58	12 Ga.	(2.6)	1"	(25.4)	1.33	(1.98)
B52S58	12 Ga.	(2.6)	1 ³ / ₁₆ "	(20.6)	1.16	(1.72)
B54S58	14 Ga.	(1.9)	1 ³ / ₁₆ "	(20.6)	.89	(1.32)
B56S58	16 Ga.	(1.5)	1 ³ / ₁₆ "	(20.6)	.79	(1.17)

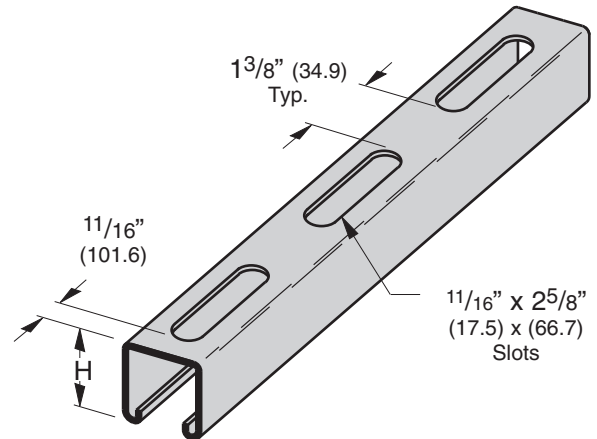

B22M THRU B54M M (MARINE RUNG) TYPE CHANNEL

• For beam loads use 90% of Channel Loading Chart

Part No.	Thickness		Height H		Weight	
	In.	mm	In.	mm	Lbs./Ft.	kg/m
B22M	12 Ga.	(2.6)	1 ⁵ / ₈ "	(41.3)	1.79	(2.66)
B24M	14 Ga.	(1.9)	1 ⁵ / ₈ "	(41.3)	1.32	(1.96)
B32M	12 Ga.	(2.6)	1 ³ / ₈ "	(34.9)	1.59	(2.36)
B42M	12 Ga.	(2.6)	1"	(25.4)	1.33	(1.98)
B44M	14 Ga.	(1.9)	1"	(25.4)	0.98	(1.46)
B52M	12 Ga.	(2.6)	1 ³ / ₁₆ "	(20.6)	1.16	(1.72)
B54M	14 Ga.	(1.9)	1 ³ / ₁₆ "	(20.6)	.89	(1.32)

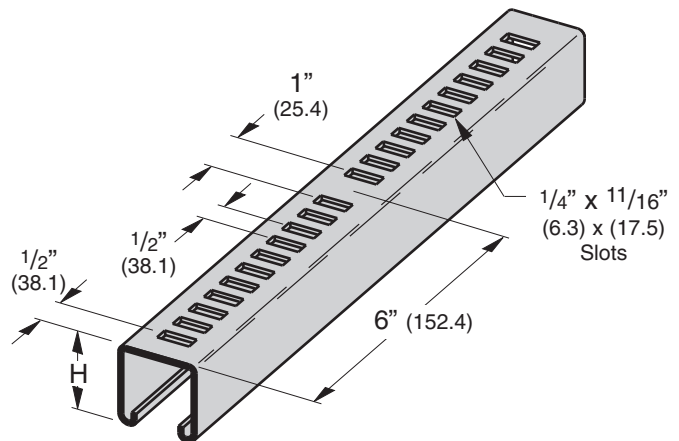

B22H25 THRU B56H25 H25 TYPE CHANNEL

• For beam loads use 90% of Channel Loading Chart

Part No.	Thickness		Height H		Weight	
	In.	mm	In.	mm	Lbs./Ft.	kg/m
B22H25	12 Ga.	(2.6)	1 ⁵ / ₈ "	(41.3)	1.85	(2.75)
B24H25	14 Ga.	(1.9)	1 ⁵ / ₈ "	(41.3)	1.36	(2.02)
B26H25	16 Ga.	(1.5)	1 ⁵ / ₈ "	(41.3)	1.09	(1.62)
B32H25	12 Ga.	(2.6)	1 ³ / ₈ "	(34.9)	1.65	(2.45)
B42H25	12 Ga.	(2.6)	1"	(25.4)	1.39	(2.07)
B52H25	12 Ga.	(2.6)	1 ³ / ₁₆ "	(20.6)	1.22	(1.81)
B54H25	14 Ga.	(1.9)	1 ³ / ₁₆ "	(20.6)	.93	(1.38)
B56H25	16 Ga.	(1.5)	1 ³ / ₁₆ "	(20.6)	.82	(1.22)

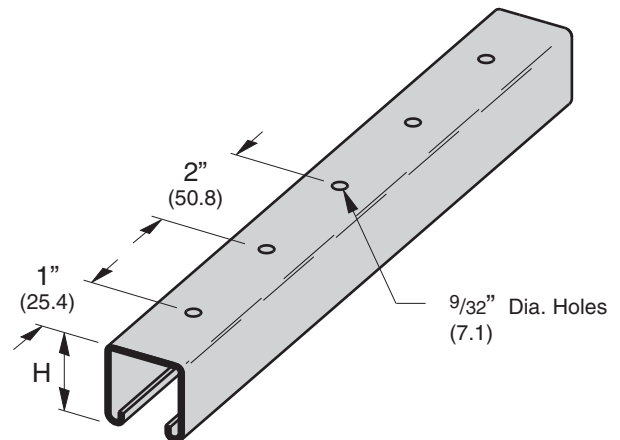

Reference page 14 for general fitting and standard finish specifications.