

Full Circle Repair Clamps 221, 226, 227 and 228

Product Specifications

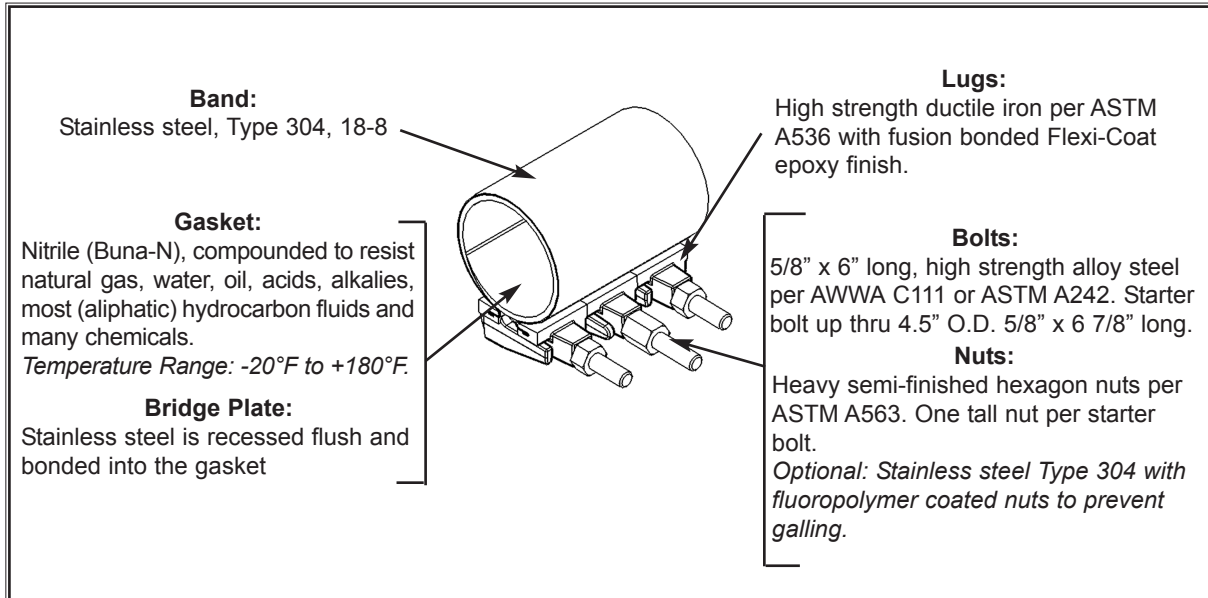

Features:

- Certified to NSF®/ANSI 61-G.
- Removable lugs to allow installation in tight spaces.
- May be used to join plain end pipe of the same diameter.
- 18-8 Type 304 Stainless Steel band for corrosion resistance.
- Standard widths 7.5" through 30" (*product 221 is 5" standard*).
- A 360° gasket seal provides maximum support and reinforcement.
- Lugs have a fusion bonded Flexi-Coat epoxy coating for corrosion resistance.
- Repair or join pipes in a wide variety of sizes and widths to fit your application.
- One starter (longer) bolt minimum per clamp thru 4.5" O.D. sizes to help with installation.
- Range up to .40" in the single band (slightly less in smaller sizes); .80" in the double band; more in larger clamps to help reduce inventory.
- Drop-in bolts feature to ease installation. If more than one band, all joints except for one will have all-closed lugs to keep bolts in place during installation.

Clamp Number	Size	Working Pressure*
221	2"-14" Nominal	50 PSI
226	2"-14" Nominal	Up to 350 PSI
227	3" - 12" Nominal	Up to 175 PSI
228	14" - 28" Nominal	Up to 100 PSI

*The allowable working pressure of a pipe repair clamp decreases as pipe diameter increases (regardless of manufacturer). For a particular installation, the allowable working pressure will be determined by the size of pipe, type of pipe, type of clamp, type and extent of damage, service conditions, environmental conditions, and installation workmanship.

Product Specifications

SPECIFICATION:

The full circle repair clamp shall have an 18-8 Type 304 stainless steel band. It shall be a minimum of 7.5" in width (5" minimum width for the 221). The lugs shall be made of high strength ductile iron per ASTM A536 GR80-55-06 and have a fusion bonded Flexi Coat epoxy coating.

The lugs shall be attached to the band by hemming the band and sliding it into the lug slot. The slot shall be cast into the lug base. The lug shall have a friction fit with the band, preventing it from sliding off, yet allowing for easy removal and reattachment in case of installing the clamp in restricted spaces.

The gasket shall be made of Nitrile (Buna N) specially compounded to resist water, oil, acids, alkalis, most (aliphatic) hydrocarbon fluids, and many other chemicals. The temperature range of the gasket shall be -20°F thru +180°F. The gasket must have a bridge plate that helps the end of the

clamp band to seal across the gap. The bridge plate shall be made of quarter-hard 304 stainless steel. It shall be recessed and bonded into the gasket. The gasket shall have a gridded pattern. The gasket shall be tapered on the ends and overlap for range capability.

All bolts shall be at least 5/8" x 6" high strength low alloy per ANSI A21.11 and B18.10. At least one 5/8" x 6 7/8" bolt with a taller nut shall be furnished to help facilitate installation of clamps up thru 4.50" O.D. Heavy semi-finished nuts meeting ASTM A563 shall be provided with the bolts. Multi-band clamps shall have all closed lugs except for one set of open and closed lugs to allow for easy opening and installation of the clamp.

OPTIONAL - Stainless steel type 304 bolts and nuts. The nuts shall be fluoropolymer coated to prevent galling.

The clamp shall be a Smith-Blair, Inc., 221, 226, 227, 228 full circle clamp or approved equal.

Approved By	
Name:	
Title:	
Date:	

THESE PRODUCT SPECIFICATIONS WERE CORRECT AT TIME OF PUBLICATION.

MATERIAL SPECIFICATIONS ARE SUBJECT TO CHANGE WITHOUT NOTICE.

SEE CATALOG BROCHURE CC-200 FOR MORE DETAILS. VISIT SMITH-BLAIR'S WEBSITE AT WWW.SMITH-BLAIR.COM TO DOWNLOAD THE MOST CURRENT INFORMATION.



Ph: 870-773-5127 • Fax: 870-773-5212 • www.smith-blair.com
Toll-Free Numbers: Ph: 800-643-9705 • Fax: 800-648-6792
30 Globe Ave, Texarkana, AR 71854 • PO Box 5337, Texarkana, TX 75505