



# model H1119.8

Barrier-Free Chilled Dual Wall Mount Fountain

## FEATURES & BENEFITS

### CONSTRUCTION

Unit is made of 18 gauge Type 304 stainless steel with a satin finish that resists stains and corrosion, and has soft, rounded corners. Unit features stainless steel satin finish back panel, vandal-resistant bottom plate, and 1-1/4" integral trap.

### INTEGRATED TRAP

All cast brass 1-1/4" NPT adjustable traps completely concealed inside bottom plates for easy installation and lack of unwanted access.

### MOUNTING

Heavy-duty galvanized steel mounting frame provides the sturdy hidden support needed for the 'Hi-Lo' configuration of this unit. Further convenience is given to the chiller with the integral fold-out shelf.

### BUBBLER HEAD

Polished chrome-plated brass bubbler head with integral basin shank for added strength. Shielded, angled stream opening provides a steady, sanitary source of drinking water at .45 gpm.

### DRINKING FOUNTAIN VALVE

The push-button activated valve offers the only all stainless steel valve body that is machined out of solid bar stock, is fully serviceable through the front of the push button assembly offering access to the water control cartridge and integral water supply strainer, and with front access to the water stream height adjustment for easy maintenance without having to remove the valve. Operating pressure range of 30 to 90 psi (2.1 to 6.2 bar).

### CUSTOM LOGO PANEL

Personalize your new or existing fountain or bottle filler where space permits with an optional customizable 10" high by 4.25" wide stainless steel panel. Virtually any company logo, event logo or graphic can be placed on this panel. Mounted with strong, moisture-resistant adhesive backing.



## SPECIFICATIONS

Model H1119.8 electric Hi-Lo wall mounted barrier-free water cooler shall include dual 18 gauge Type 304 Stainless Steel satin finish basins, push-button operated stainless steel valves with front-accessible cartridge, in-line strainer and flow adjustment, 100% lead-free waterways, polished chrome-plated brass vandal-resistant bubbler heads, polished chrome-plated vandal-resistant waste strainers, vandal-resistant stainless bottom plates, stainless steel satin finish back panel and louvered intrusion-proof grill, high and low fountain mounting levels, and 1-1/4" NPT concealed all cast-brass traps. The R-134a refrigeration system is hermetically sealed and delivers a minimum of 8 gph (30.3 L) of water at 50° F (10° C) cooled from 80° F (26.7° C) inlet water at 90° F (32.2° C) ambient. 115 Volts, 60Hz, rated watts: 370, full load amps: 5. ....

REQUIRES MODEL HCR8 AND MTGFR.LG PRICED SEPARATELY.

## OPTIONS

- Custom Logo Panel: Model 6475, Hydration By Haws™ logo panel with customization options.
- Cane Detection, Floor Mounted: Model SK6, floor mounted cane detection for the Haws Hi-Lo drinking fountains.
- Bottle Filler: Model 1920, bottle filler can be a stand-alone station, or mounted above Haws 1001, 1011, 1107L, 1109, 1117L, and 1119 series drinking fountain models.
- Back Panel: Model BP32, satin finish stainless steel 32" back panel for model 1920 bottle filler.

For more information, visit [www.hawsc.com](http://www.hawsc.com) or call (888) 640-4297.

## APPLICATIONS

Perfect for either public or private settings, our stainless steel electric drinking fountains are a great fit in indoor environments. Specifically, this type fountain may be placed in settings such as: schools, office buildings, shopping malls, and other indoor environments. Electric water coolers are not recommended or designed for outdoor applications or enclosed pool areas (chlorine). These conditions may void warranty. Model meets all current Federal Regulations for the disabled including those in the Americans with Disabilities Act. Haws manufactures drinking fountains and electric water coolers to be lead-free by all known definitions including NSF/ANSI Standard 61, Section 9, NSF/ANSI 372, California Proposition 65, and the Federal Safe Drinking Water Act. Product is compliant to California Health and Safety Code 116875 (AB 1953-2006). Haws electric water coolers comply with ARI Standard 1010 and ANSI A117.1, and are listed by Underwriter Laboratories to U.S. and Canadian standards.



**NOTES:**

1. HOLD ROUGH-IN DIMENSIONS ± 1/8" (3.2mm)
2. WHEN INSTALLING THIS UNIT, LOCAL, STATE OR FEDERAL CODES SHOULD BE ADHERED TO. FOR INSTALLATION HEIGHTS OTHER THAN SHOWN, DIMENSIONS MARKED (\*) MUST BE ADJUSTED ACCORDINGLY.
3. ALIGN HOLES IN CHILLER SUPPORT TRAY WITH HOLES IN FRAME AND FASTEN WITH #10 SHEET METAL SCREWS.
4. REFER TO 5874 SERIES OPERATION AND MAINTENANCE MANUAL FOR PUSH BUTTON AND VALVE INSTALLATION/MAINTENANCE INSTRUCTIONS.
5. REFER TO MTGFR.LG INSTALLATION DRAWING FOR ROUGH-IN DIMENSIONS.
6. INSERT 5/16"-18 PANEL INSERTS FROM OPPOSITE SIDE AT LOCATIONS SHOWN BY DARKENED HOLES. HOLE COMBINATIONS SHOWN ARE FOR USE WITH LOW FOUNTAIN ON THE RIGHT AND THE HI FOUNTAIN ON THE LEFT. USE OPPOSITE HOLES FOR HI ON RIGHT AND LOW ON LEFT.
7. HOLE COMBINATION SHOWN BELOW IS FOR USE WITH LOW FOUNTAIN ON THE RIGHT AND HIGH FOUNTAIN ON THE LEFT. USE OPPOSITE HOLES FOR HIGH ON RIGHT AND LOW ON LEFT.
8. TO CHANGE FOUNTAIN MTG. SCREW LOCATIONS: FIRST REMOVE SCREWS AND THEN SQUEEZE CLIPS ON NUT RETAINER TO POP OUT. SNAP INTO NEW POSITIONS AND RE-ASSEMBLE SCREWS.
9. IMPORTANT: A L.H. LOW (OPTIONAL) CONFIGURATION WILL REQUIRE A DIFFERENT BACK PANEL AND THE WASTE AND SUPPLY DIMENSIONS SHOWN (\*) MUST BE REVERSED.

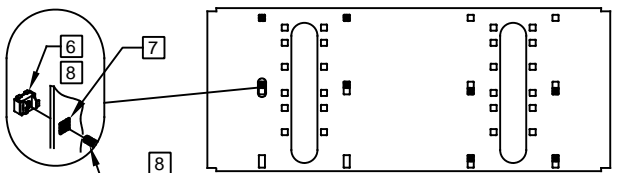
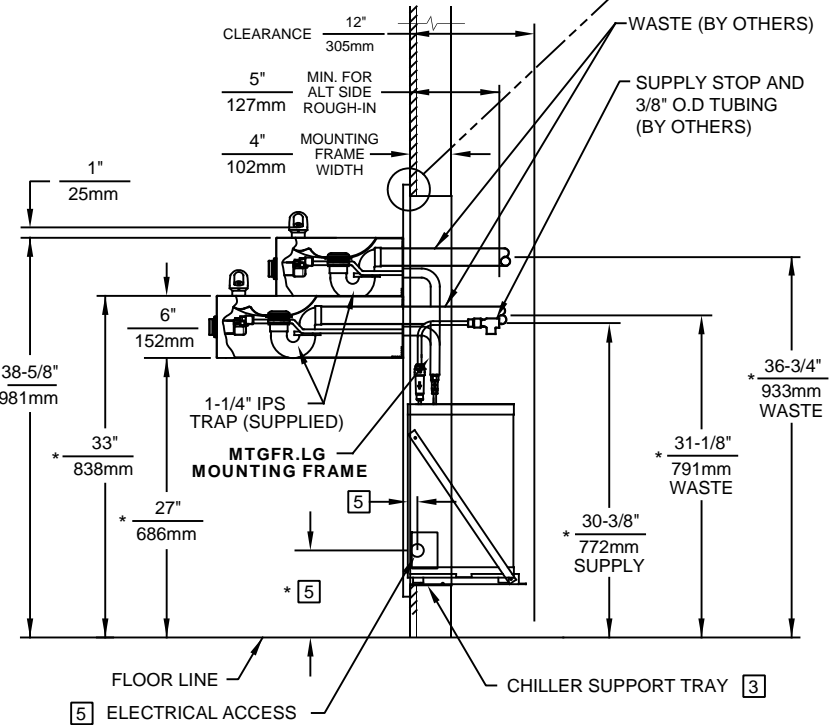
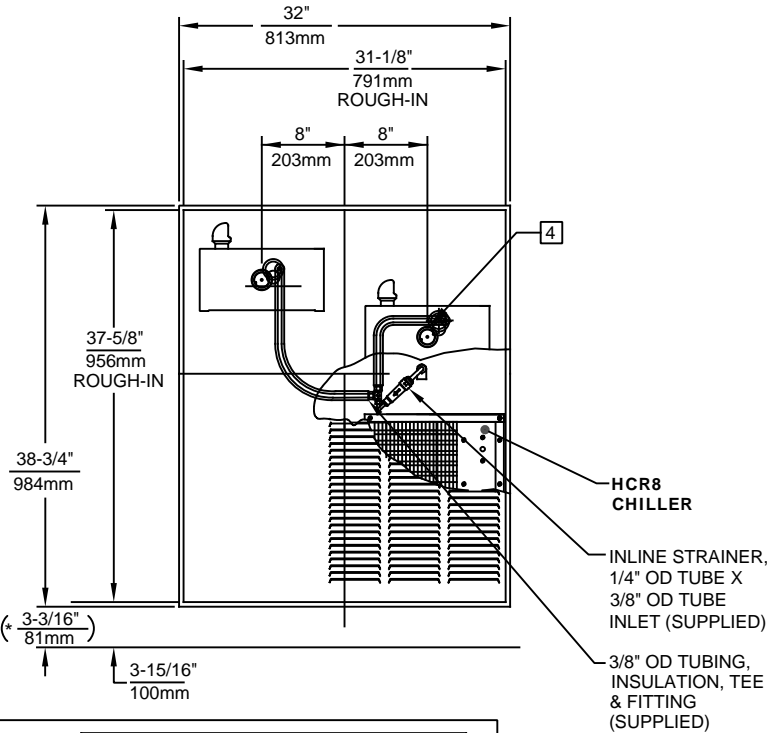
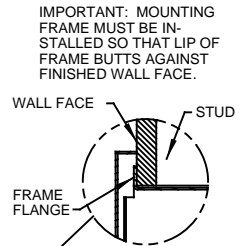
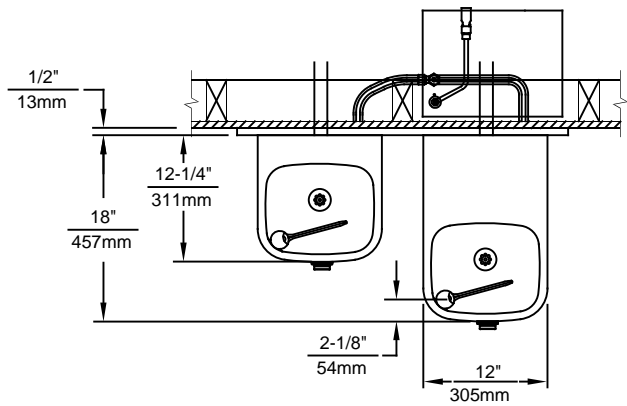

**BOWL MOUNTING PATTERN DETAIL**

1455 KLEPPE LANE  
SPARKS, NEVADA 89431  
(775) 359-4712 FAX (775) 359-7424  
E-MAIL: HAWS@HAWS.CO.COM  
WEBSITE: WWW.HAWS.CO.COM

ECN NO.	REVISED PER	BY:	MODEL(S)	PART NUMBER
	ECN: 5190	JP		0002080262.D
DRAWN:	DATE:	CHKD.:	H1119.8	REVISION
F.VASQUEZ	09-01-98	FV		21
APPROVED:	DATE:	SCALE:	DRAWING TYPE:	SHEET 1 OF 1
FV	07/07/17	1:19	INSTALLATION	