

# spirax sarco

## Balanced Pressure Thermostatic Steam Trap T250

The T250 has a welded stainless steel element, which is self-adjusting over the entire operating pressure range and will discharge condensate at approximately 20°F (11°C) below saturated steam temperature.

Model	T250	
	Angle	Straightway
PMO	250 psig	
Sizes	1/2", 3/4" & 1"	1/2" & 3/4"
Connections	NPT	
Construction	Cast Iron Body & Cover Stainless Steel Internals	

### Limiting Operating Conditions

**Max. Operating Pressure (PMO)** 250 psig (17 barg)

**Max. Operating Temperature** Saturated Steam Temperature

### Pressure Shell Design Conditions

**PMA** 250 psig/up to 450°F 17 barg/up to 232°C  
Max. allowable pressure

**TMA** 450°F/0-250 psig 232°C/0-17 barg  
Max. allowable temperature

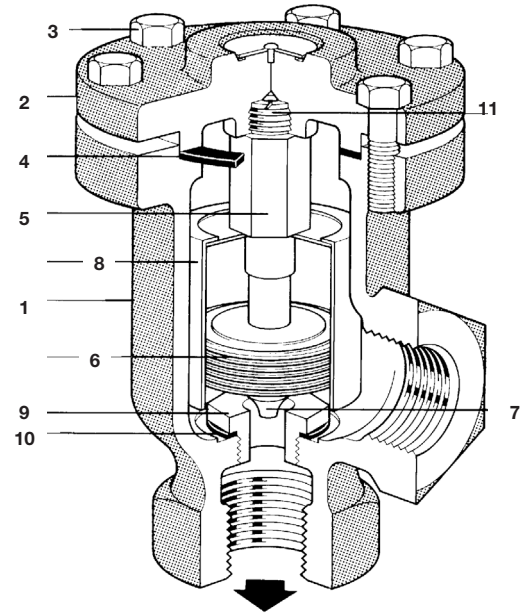

### Construction Materials

No.	Part	Material	
1	Body	Cast Iron	ASTM A126 CL B
2	Cap	Cast Iron	ASTM A126 CL B
3	Cap Screws	Steel	ASTM A449
4	Cap Gasket	Stainless Steel Clad Non-Asbestos Fill	
5	Element Assembly	Stainless Steel	
6	Bellows	Stainless Steel	
7	Valve Head	Stainless Steel	
8	Bellows Shield (1" only)	Stainless Steel	
9	Valve Seat	Stainless Steel	
10	Valve Seat Gasket Non-Asbestos Fill	Stainless Steel Clad	
11	Lockwasher	Stainless Steel	
12	Plug (Stwy. only)	Forged Steel	

### Typical Applications

Hospital, laundry and kitchen equipment, high capacity process equipment, outdoor applications subject to freezing, applications requiring high air venting capacity on initial start up.

### Capacities Hot Condensate lb/h

Inlet Pressure	Hot Condensate lb/h				
	psig	barg	1/2"	3/4"	1"
1	.07		620	850	1300
2	.14		820	1200	1750
5	.34		1200	1650	2600
10	.70		1580	2225	3500
15	1.0		1800	2650	4200
20	1.4		2100	2950	4600
30	2.1		2450	3500	5500
40	2.8		2750	4000	6200
50	3.5		3100	4400	6850
60	4.1		3300	4700	7250
75	5.2		3650	5050	8000
100	6.9		4200	5750	9000
125	8.6		4400	6150	9650
150	10.3		5000	7000	11000
175	12.1		5275	7450	11750
200	13.8		5600	7800	12100
225	15.6		5900	8200	12500
250	17.2		6000	8500	13500

Orifice Size = .375" .438" .500"

Discharge Capacities shown were obtained from tests using hot condensate approximately 20°F below Saturated Steam temperature. When condensate temperature is below 200°F, discharge capacity is from two to three times greater than shown above.

*Local regulation may restrict the use of this product below the conditions quoted. Limiting conditions refer to standard connections only.  
In the interests of development and improvement of the product, we reserve the right to change the specification.*

TI-2-009-US 2.14

# Balanced Pressure Thermostatic Steam Trap T250

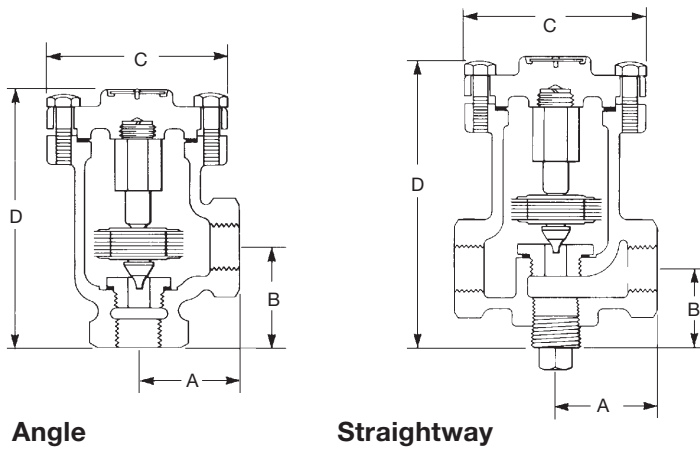

Dimensions (nominal) in inches and millimeters					
Size	A	B	C	D	Weight
<b>Angle</b>					
1/2"	1.75 44	1.75 44	3.12 79	4.56 116	3.5 lb 1.6 kg
3/4"	1.75 44	1.75 44	3.12 79	4.56 116	3.5 lb 1.6 kg
1"	2.12 54	2.25 57	3.9 100	5.37 137	6.0 lb 2.7 kg
<b>Straightway</b>					
1/2"	1.75 44	1.75 44	3.12 79	5.37 137	4.3 lb 1.9 kg
3/4"	1.87 48	1.75 44	3.12 79	5.37 137	4.3 lb 1.9 kg

## Sample Specification

Steam traps shall be balanced pressure thermostatic types, self-adjusting to all pressures within their operating range. Bodies to be of heavy cast iron with NPT connections. Thermostatic elements shall be of precision welded stainless steel construction. All internals to be stainless steel and shall be replaceable without disturbing the piping connections.

## Installation

A pipeline strainer should be installed ahead of any steam trap to protect the valve and seat from dirt and scale. Full port isolating valves should be placed to permit servicing. The trap should be installed below the drainage point of the equipment with a collecting leg before the trap. For best operation, the bellows should be in a horizontal position as shown. For a freeze-resistant installation, inlet piping must be pitched toward the trap for gravity flow, and the trap outlet must be free of any piping. See installation instructions #250-D8.

## Maintenance

This product can be maintained without disturbing the piping connections. Complete isolation from both supply and return line is required before any servicing is performed. The trap should be disassembled periodically for inspection and cleaning of the valve head and seat. Worn or damaged parts should be replaced using a complete element set.

**Complete installation and maintenance instructions are given in IMI 2.004, which accompanies the product.**

## Spare Parts

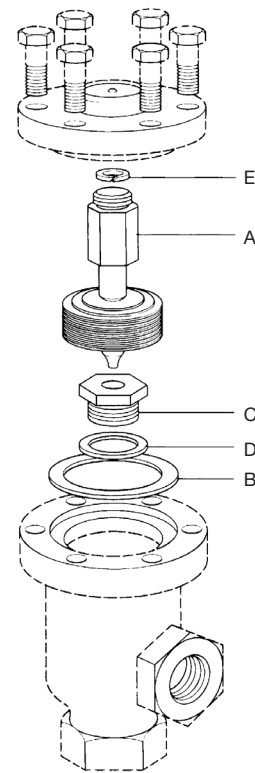

Element Set	A, B, C, D, E
Cap Gasket	B

Available spare parts are shown in heavy outline.  
Angle & straightway traps accept the same spare parts.

**We certify that the data as given  
on this sheet are correct.**

Signed: \_\_\_\_\_

Date: \_\_\_\_\_

TI-2-009-US 2.14