

## Installation / Operation / Maintenance

### Applies to: **Model X Indoor Duct Furnace**



### **WARNING:**

#### **FIRE OR EXPLOSION HAZARD**

Failure to follow safety warnings exactly could result in serious injury, death, or property damage.

Be sure to read and understand the installation, operation, and service instructions in this manual.

Improper installation, adjustment, alteration, service, or maintenance can cause serious injury, death, or property damage.

- Do not store or use gasoline or other flammable vapors and liquids in the vicinity of this or any other appliance.
- **WHAT TO DO IF YOU SMELL GAS**
  - Do not try to light any appliance.
  - Do not touch any electrical switch; do not use any phone in your building.
  - Leave the building immediately.
  - Immediately call your gas supplier from a phone remote from the building. Follow the gas supplier's instructions.
  - If you cannot reach your gas supplier, call the fire department.
- Installation and service must be performed by a qualified installer, service agency, or the gas supplier.

## Table of Contents

<p><b>1.0 General ..... 2</b></p> <p>1.1 Hazard Labels and Notices ..... 2</p> <p>1.2 General Installation Information ..... 2</p> <p>1.3 Warranty ..... 3</p> <p>1.4 Installation Codes ..... 3</p> <p><b>2.0 Furnace Location ..... 3</b></p> <p>2.1 General Recommendations ..... 3</p> <p>2.2 Combustion Air Requirements for a Heater Located in a Confined Space ..... 4</p> <p><b>3.0 Uncrating and Preparation ..... 4</b></p> <p>3.1 Uncrating and Inspecting ..... 4</p> <p>3.2 Preparing the Furnace for Installation ..... 5</p> <p><b>4.0 Dimensions and Clearances ..... 6</b></p> <p>4.1 Dimensions ..... 6</p> <p>4.2 Clearances ..... 6</p> <p><b>5.0 Suspending or Mounting the Furnace ..... 7</b></p> <p>5.1 Weight ..... 7</p> <p>5.2 Suspending the Furnace ..... 7</p> <p>5.3 Mounting the Furnace ..... 7</p> <p><b>6.0 Mechanical ..... 7</b></p> <p>6.1 Gas Piping and Pressures ..... 7</p> <p>6.2 Venting ..... 9</p> <p>6.3 Duct Furnace Airflow ..... 11</p> <p><b>7.0 Electrical Supply and Wiring ..... 16</b></p> <p>7.1 General ..... 16</p>	<p>7.2 Supply Voltage and Wiring ..... 16</p> <p>7.3 Thermostat and Control Wiring ..... 16</p> <p>7.4 Typical Wiring Diagrams ..... 17</p> <p><b>8.0 Controls ..... 19</b></p> <p>8.1 Fan Control ..... 19</p> <p>8.2 Limit Control ..... 19</p> <p>8.3 Blocked Vent Switch ..... 19</p> <p>8.4 Gas Controls ..... 19</p> <p>8.5 Pilot and Ignition Systems ..... 21</p> <p>8.6 Burner Carryover System and Air Adjustment ..... 22</p> <p><b>9.0 Commissioning and Startup ..... 23</b></p> <p>9.1 Check the installation prior to startup ..... 23</p> <p>9.2 Startup ..... 23</p> <p>9.3 Check installation after startup ..... 23</p> <p><b>10.0 Maintenance and Service ..... 24</b></p> <p>10.1 Maintenance Schedule ..... 24</p> <p>10.2 Maintenance Procedures ..... 25</p> <p>10.3 Troubleshooting ..... 27</p> <p><b>APPENDIX ..... 28</b></p> <p>Converting Model X Duct Furnace for Lower Temperature Rise / Higher CFM Application ..... 28</p> <p>Wiring Diagrams for Match-Lit Pilot Discontinued in 2003 ..... 30</p> <p><b>INDEX ..... 31</b></p> <p><b>INSTALLATION RECORD ..... 32</b></p>
--	--

## 1.0 General

### 1.1 Hazard Labels and Notices

There are warning labels on the unit and throughout this manual. For your safety, read the definitions below and comply with all boxes labeled CAUTION, WARNING, and DANGER during installation, operation, maintenance, and service of this heater.

#### Definitions of HAZARD INTENSITY LEVELS used in this Manual

- 1. DANGER: Failure to comply will result in severe personal injury or death and/or property damage.**
- 2. WARNING: Failure to comply could result in severe personal injury or death and/or property damage.**
- 3. CAUTION: Failure to comply could result in minor personal injury and/or property damage.**

#### WARNING

**Gas-fired appliances are not designed for use in hazardous atmospheres containing flammable vapors or combustible dust, in atmospheres containing chlorinated or halogenated hydrocarbons, or in applications with airborne silicone substances. See Hazard Levels, above.**

## 1.2 General Installation Information

Installation should be done by a qualified agency in accordance with the instructions in this manual and in compliance with all codes and requirements of authorities having jurisdiction.

The instructions in this manual apply to a Model X duct furnace.

### 1.3 Warranty

Refer to the limited warranty form in the "Literature Bag".

---

#### **WARRANTY: Warranty is void if.....**

---

- a. Furnaces are used in atmospheres containing flammable vapors or atmospheres containing chlorinated or halogenated hydrocarbons or any contaminant (silicone, aluminium oxide, etc.) that adheres to the spark ignition flame sensing probe.
  - b. Wiring is not in accordance with the diagram furnished with the heater.
  - c. Unit is installed without proper clearances to combustible materials or located in a confined space without proper ventilation and air for combustion. (See Paragraphs 2.2 and 4.2.)
  - d. Furnace air throughput is not adjusted within the range specified on the rating plate.
  - e. Duct furnace is installed in a process or drying application without factory authorization. (Any use in a process or drying application voids agency certification.)
- 

### 1.4 Installation Codes

The duct furnaces covered in this manual are design-certified by the Canadian Standards Association to ANSI Z83.8a and CSA 2.6 for use with either natural or propane gas. The type of gas for which the furnace is equipped and the correct firing rate are shown on the rating plate attached to the unit. Electrical characteristics are shown on the unit rating plate.

These units must be installed in accordance with local building codes. In the absence of local codes, in the United States, the unit must be installed in accordance with the National Fuel Gas Code (latest edition). A Canadian installation must be in accordance with the CAN/CGA B149.1 and B149.2 Installation Code for Gas Burning Appliances and Equipment. These codes are available from CSA Information Services, 1-800-463-6727. Local authorities having jurisdiction should be consulted before installation is made to verify local codes and installation procedure requirements.

#### **Special Installations (Aircraft Hangars/Garages)**

Installations in aircraft hangars should be in accordance with ANSI/NFPA No. 409 (latest edition), Standard for Aircraft Hangars; in public garages in accordance with ANSI/NFPA No. 88A (latest edition), Standard for Parking Structures; and for repair garages in accordance with ANSI/NFPA No. 88B (latest edition), Standard for Repair Garages. ANSI/NFPA-88 (latest edition) specifies overhead heaters must be installed at least eight feet above the floor. In Canada, installations in aircraft hangars should be in accordance with the requirements of the enforcing authorities, and in public garages in accordance with CSA B149 codes.

#### **WARNING**

**These duct furnaces are not certified or approved for use in drying or process applications. If a duct furnace is to be used in a drying or process application, contact the factory for application guidelines and manufacturer's authorization. Without factory authorization, the warranty is void, and the manufacturer disclaims any responsibility for the duct furnace and/or the application.**

#### **WARNING**

**To ensure safety, follow lighting instructions located on the outlet box cover.**

### 2.0 Furnace Location

#### 2.1 General Recommendations

A duct furnace is designed for connection to an inlet and an outlet duct and depends on an external air handler. Location must comply with the clearances listed in Paragraph 4.2. There are a variety of factors, such as system application, building structure, dimensions, and weight, that contribute to selecting the location. Read the installation information in this manual and select a location that complies with the requirements.

#### **WARNING**

**Avoid installing a furnace in extremely drafty areas. Extreme drafts can shorten the life of the heat exchanger and/or cause safety problems.**

## 2.0 Furnace Location (cont'd)

## 2.2 Combustion Air Requirements for a Heater Located in a Confined Space

These duct furnaces are designed to take combustion air from the space in which the furnace is installed. The air that enters into the combustion process is vented to the outdoors. Sufficient air must enter the equipment location to replace the air exhausted through the vent system. Modern construction methods involve the greater use of insulation, improved vapor barriers and weather-stripping, with the result that buildings generally are much tighter structurally than they have been in the past. The combustion air supply for gas-fired equipment can be affected by these construction conditions because infiltration that would have existed in the past may not be adequate. Extensive use of exhaust fans aggravates the situation. In the past the filtration of outside air assumed in heat loss calculations (one air change per hour) was assumed to be sufficient. However, current construction methods may now require the introduction of outside air into the space through wall openings or ducts.

Requirements for combustion air and ventilation air depend upon whether the unit is located in a confined or unconfined space. An "unconfined space" is defined as a space whose volume is not less than 50 cubic feet per 1000 BTUH of the installed appliance. Under all conditions, enough air must be provided to ensure there will not be a negative pressure condition within the equipment room or space. A positive seal must be made in all return-air connections and ducts. Even a slight leak can create a negative pressure condition in a confined space and affect combustion.

**Do not** install a unit in a confined space without providing wall openings leading to and from the space. Provide openings near the floor and ceiling for ventilation and air for combustion as shown in **FIGURE 1**, depending on the combustion air source as noted in Items 1, 2, and 3 below the illustration.

Add total BTUH of all appliances in the confined space and divide by figures below for square inch free area size of each (top and bottom) opening.

**1. Air from inside the building** -- openings 1 square inch free area per 1000 BTUH. Never less than 100 square inches free area for each opening. See (1) in **FIGURE 1**.

**2. Air from outside through duct** -- openings 1 square inch free area per 2000 BTUH. See (2) in **FIGURE 1**.

**3. Air direct from outside** -- openings 1 square inch free area per 4000 BTUH. See (3) in **FIGURE 1**.

**NOTE:** For further details on supplying combustion air to a confined space, see the National Fuel Gas Code ANSI Z223.1a (latest edition).

**FIGURE 1 - Confined Space: A space whose volume is less than 50 cubic feet per 1000 BTUH of the installed appliance input rating**

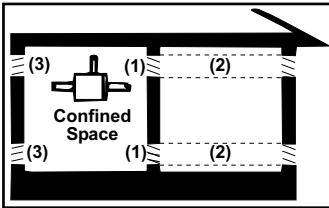

### WARNING

**These furnaces are designed to take combustion air from the space in which the unit is installed and are not designed for connection to outside combustion air intake ducts. Connecting outside air duct voids the warranty and could cause hazardous operation. See Hazard Levels, page 2.**

### Hazards of Chlorine

The presence of chlorine vapors in the combustion air of gas-fired heating equipment presents a potential corrosion hazard. Chlorine will, when exposed to flame, precipitate from the compound, usually freon or degreaser vapors, and go into solution with any condensation that is present in the heat exchanger or associated parts. The result is hydrochloric acid which readily attacks all metals including 300 grade stainless steel.

Care should be taken to separate these vapors from the combustion process. This may be done by wise location of the furnace with regard to exhausters or prevailing wind direction. Remember, chlorine is heavier than air. This fact should be kept in mind when determining installation locations of heating equipment and building exhaust systems.

## 3.0 Uncrating and Preparation

### 3.1 Uncrating and Inspecting

This furnace was test operated and inspected at the factory prior to crating and was in operating condition. If the furnace has incurred any damage in shipment, document the damage with the transporting agency and immediately contact an authorized factory distributor. If you are a distributor, follow the FOB freight policy procedures.

Check the rating plate for the gas specifications and electrical characteristics of the furnace to be sure that they are compatible with the gas and electric supplies at the installation site.

### 3.2 Preparing the Furnace for Installation

Read this booklet and become familiar with the installation requirements of your particular furnace. If you do not have knowledge of local requirements, check with the local gas company or any other local agencies who might have requirements concerning this installation. Before beginning, make preparations for necessary supplies, tools, and manpower.

Check to see if there are any field-installed options that need to be assembled to the furnace prior to installation.

Option Parts -- Some gas control options will have parts either shipped loose with the heater or shipped separately. If your unit is equipped with any of the gas control options listed below, be sure these parts are available at the job site.

Application	Opt	Shipped Separate Components
Heating - Gas Control	AG7	Thermostat, P/N 48033
Makeup Air - Gas Control Options	AG3	Control Switch, P/N 29054
	AG8	Control Switch, P/N 29054; Sensor & Mixing Tube, P/N 48041
	AG9	Control Switch, P/N 29054; Remote Temperature Selector, P/N 48042; Sensor & Mixing Tube, P/N 48041
	AG15	Control Switch, P/N 29054; Remote Temperature Selector, P/N 115848; Stage Adder Module, P/N 115849; Discharge Air Sensor Holder, P/N 115850; Discharge Air Sensor Holder Bracket, P/N 213612

Other shipped-separate options could include a vent damper, a power venter, a gas shutoff valve, a condensate drain fitting, a thermostat, and/or a disconnect switch.

Model X furnaces are equipped with directional air baffles between the heat exchanger tubes. Facing the control compartment of the furnace, the standard direction of airflow is from left to right. An installation requiring direction of airflow from right to left when facing the control compartment requires repositioning of the directional air baffles at the installation site. Follow the instructions in **FIGURE 2** to change the position of baffles:

#### 3.2.1 Instructions for Reversing Airflow by Changing Directional Air Baffles in the Heat Exchanger

**FIGURE 2 - Heat Exchanger Directional Air Baffles**

- Remove Screws "A". Individually lift each baffle slightly and slide forward. Remove all baffles completely from the heat exchanger.
- Remove Screws "B" and the top baffle support assembly. Re-position the assembly to the opposite end of the heat exchanger and attach.
- Remove Screws "C" and the assembled bottom baffle support and brackets. Plug the holes in the heat exchanger bottom by re-inserting the screws in the holes. Position the assembly on the opposite end of the heat exchanger and attach using field-supplied sheetmetal screws.
- Re-install all of the individual baffles by reversing the procedure in Step a) above.

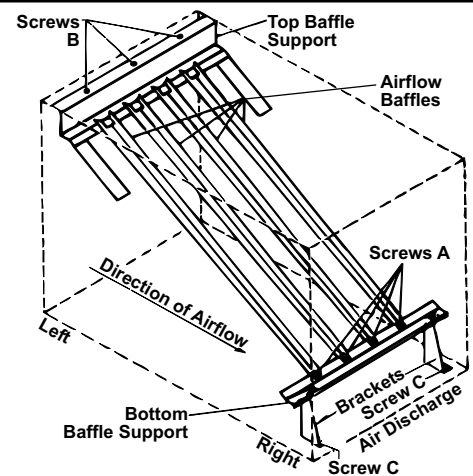

#### 3.2.2 Change the Vent Outlet Direction

**FIGURE 3 - Horizontal or Vertical Flue Connection**

The vent outlet may be horizontal or vertical.  
**To change orientation (vertical or horizontal) of the flue connection:**  
**(1) Remove screws; (2) Reverse position; (3) Re-fasten.**

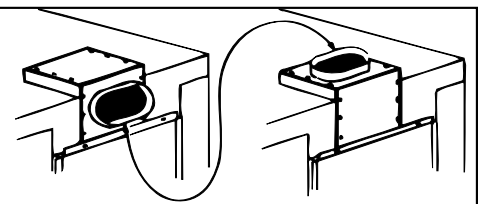

#### 3.2.3 Install Condensate Drain, Option CS1

Condensate can form in the heat exchanger of furnaces installed as makeup air units or when installed downstream from a cooling coil. Under these conditions, a drain flange, Option CS1, may be installed on the furnace bottom as shown in **FIGURE 4**. When using Option CS1, seal all corners and the four square holes in the bottom pan edge. **NOTE:** A 4-inch (102mm) minimum clearance is required under the furnace if a 90° street elbow is used.

**FIGURE 4 - Condensate Drain, Option CS1 (P/N 31765)**

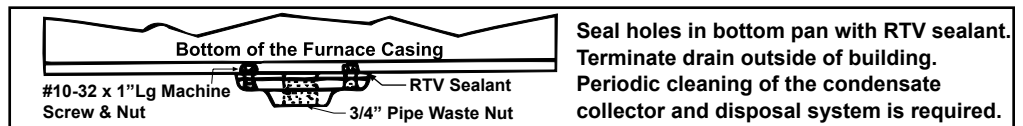

## 4.0 Dimensions and Clearances

### 4.1 Dimensions

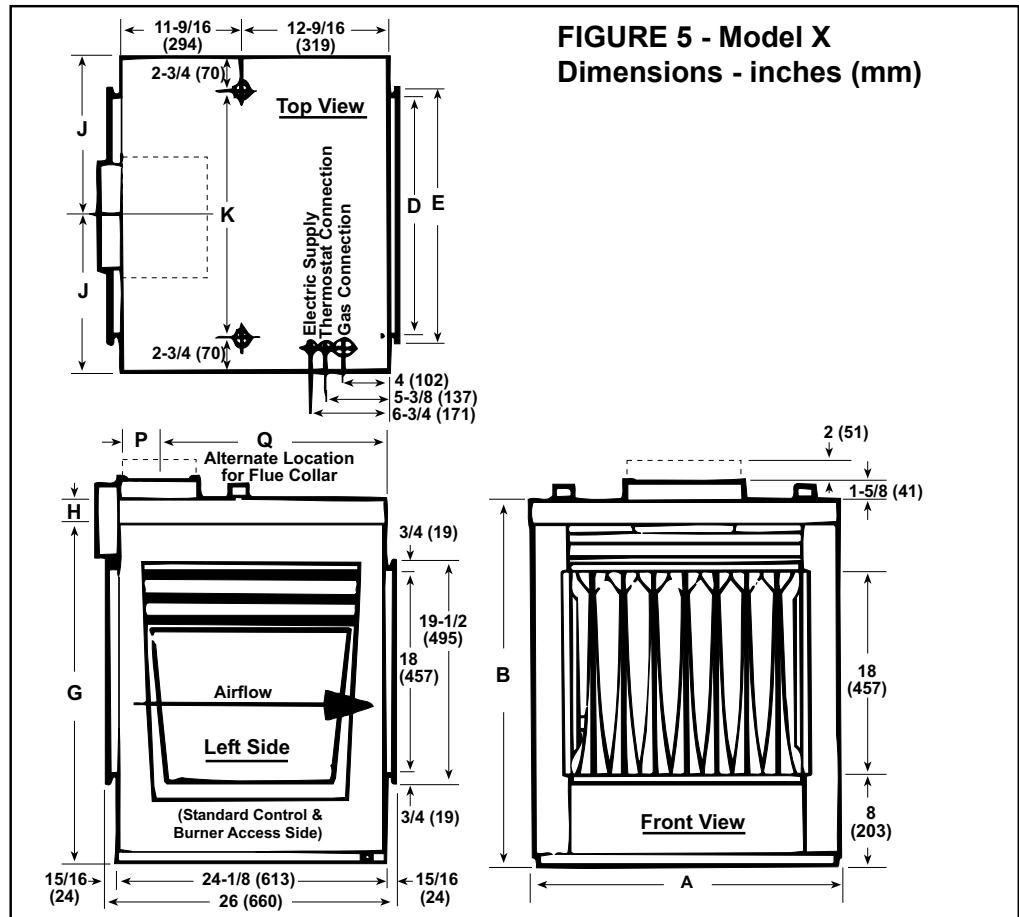

**FIGURE 5 - Model X  
Dimensions - inches (mm)**

Size	A	B	D	E	G	H	J	K	P	Q	Flue
<b>Dimensions (inches)</b>											
75	19-1/4	32-1/4	12-1/2	14	30-1/4	2	9-5/8	13-3/4	3-1/2	20-3/4	5" Round
100	19-1/4	32-1/4	12-1/2	14	30-1/4	2	9-5/8	13-3/4	3-1/2	20-3/4	6" Round
125	22	32-1/4	15-1/4	16-3/4	30-1/4	2	11	16-1/2	3-1/2	20-3/4	7" Oval
150, 175	27-1/2	32-1/4	20-3/4	22-1/4	30-1/4	2	13-3/4	22	3-1/2	20-3/4	8" Oval
200, 225	33	35-1/4	26-1/4	27-3/4	31-3/4	3-1/2	16-1/2	27-1/2	5	19-1/4	8" Round
250, 300	41-1/4	35-1/4	34-1/2	36	31-3/4	3-1/2	20-5/8	35-3/4	5	19-1/4	10" Oval
350	46-3/4	35-1/4	40	41-1/2	31-3/4	3-1/2	23-5/8	41-1/4	5	19-1/4	12" Oval
400	52-1/4	35-1/4	45-1/2	47	31-3/4	3-1/2	26-1/8	46-3/4	5	19-1/4	12" Oval
<b>Dimensions (mm)</b>											
75	489	819	318	356	768	51	244	349	89	527	127 Round
100	489	819	318	356	768	51	244	349	89	527	152 Round
125	559	819	387	425	768	51	279	419	89	527	178 Oval
150, 175	699	819	527	565	768	51	349	559	89	527	203 Oval
200, 225	838	895	667	705	806	89	419	699	127	489	203 Round
250, 300	1048	895	876	914	806	89	524	908	127	489	254 Oval
350	1188	895	1016	1054	806	89	600	1048	127	489	305 Oval
400	1327	895	1156	1194	806	89	664	1187	127	489	305 Oval

### 4.2 Clearances

**NOTE:** To have sufficient space to remove the drawer-type burner rack, the clearance on the control side of the furnace must be the width of the furnace plus 6" (152mm).

Clearance to combustibles is defined as the minimum distance from the heater to a surface or object that is necessary to ensure that a surface temperature of 90°F above the surrounding ambient temperature is not exceeded.

Clearance is also required to sides of furnace for combustion air space and for convenient installation and burner control service.

<b>Required Clearances</b>				
<b>Top</b>	<b>Sides</b>		<b>Bottom</b>	
	<b>Control</b>	<b>Opposite</b>	<b>To Combustibles</b>	<b>To Non-Combustibles</b>
6" (152mm)	See Note	6" (152mm)	3" (76mm)	0

## 5.0 Suspending or Mounting the Furnace

### 5.1 Weight

### 5.2 Suspending the Furnace

### 5.3 Mounting the Furnace

## 6.0 Mechanical

### 6.1 Gas Piping and Pressures

#### WARNING

**Unit must be supported level for proper operation. Do not place or add additional weight to the suspended unit.**

Before installing the furnace, check the supporting structure to be used to verify that it has sufficient load-carrying capacity to support the weight of the unit.

Net Weight											
Size	75	100	125	150	175	200	225	250	300	350	400
lbs	150	150	163	182	186	224	231	276	286	320	355
kg	68	68	74	83	84	102	105	125	130	145	161

These duct furnaces have two-point suspension. See hanger centerline dimensions in **FIGURE 5**, page 6.

At each suspension point, the furnace is factory-equipped with a free-turning, female, 1" (NPT), pipe hanger. Suspend by connecting the pipe hanger to a 1" threaded pipe. See **FIGURE 6** (left side).

As an alternative method, the factory-installed pipe hanger may be removed and the heater suspended as illustrated on the right in **FIGURE 6**.

**FIGURE 6 - Suspending the Furnace**

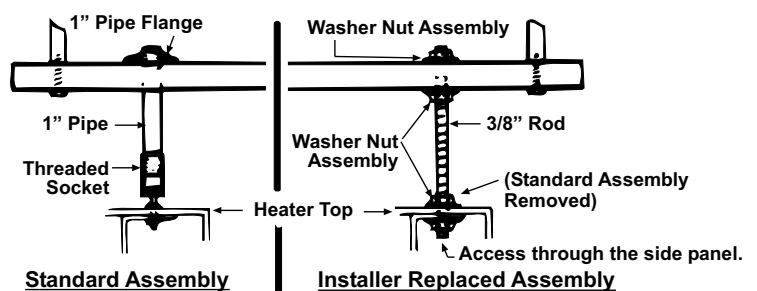

A minimum of 3" (76mm) clearance is required from the bottom of the unit to a combustible surface. See **FIGURE 7** for an illustration of field-fabricated supports.

**FIGURE 7 - Field-Fabricated Support**

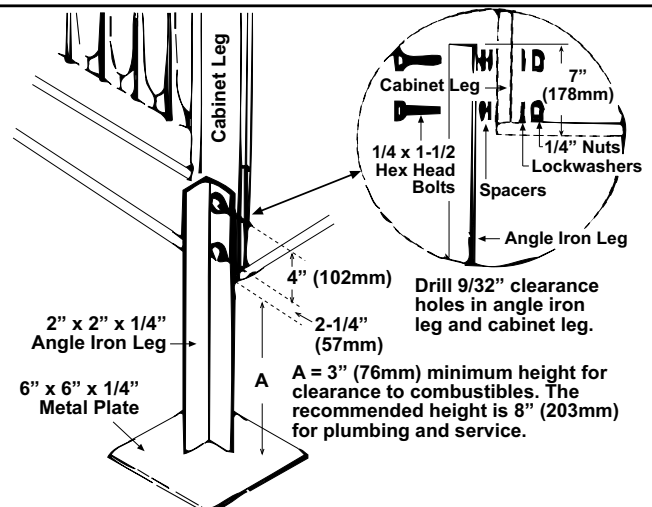

**NOTE:** Drawing is not proportional; comply with dimensions as written.

Drill 9/32" clearance holes in angle iron leg and cabinet leg.  
A = 3" (76mm) minimum height for clearance to combustibles. The recommended height is 8" (203mm) for plumbing and service.

### 6.1.1 Gas Supply and Connections

#### WARNING

**This appliance is equipped for a maximum gas supply pressure of 1/2 psi, 3.4 kPa, or 14 inches water column. Supply pressure higher than 1/2 psi requires installation of an additional service regulator external to the unit.**

#### PRESSURE TESTING SUPPLY PIPING

**Test Pressures Above 1/2 PSI:** Disconnect the heater and manual valve from the gas supply line which is to be tested. Cap or plug the supply line.

**Test Pressures Below 1/2 PSI:** Before testing, close the manual valve on the heater.

## 6.0 Mechanical (cont'd)

### 6.1 Gas Piping and Pressures (cont'd)

#### Sizing a Gas Supply Lines

All piping must be in accordance with requirements outlined in the National Fuel Gas Code ANSI/Z223.1a (latest edition) or CAN/CGA-B149.1 and B149.2 (See Paragraph 1.4). Gas supply piping installation should conform with good practice and with local codes.

Capacity of Piping												
Cubic Feet per Hour based on 0.3" w.c. Pressure Drop												
Specific Gravity for Natural Gas -- 0.6 (Natural Gas -- 1000 BTU/Cubic Ft)												
Specific Gravity for Propane Gas -- 1.6 (Propane Gas -- 2550 BTU/Cubic Ft)												
Length of Pipe	Diameter of Pipe											
	1/2"		3/4"		1"		1-1/4"		1-1/2"		2"	
	Natural	Propane	Natural	Propane	Natural	Propane	Natural	Propane	Natural	Propane	Natural	Propane
20'	92	56	190	116	350	214	730	445	1100	671	2100	1281
30'	73	45	152	93	285	174	590	360	890	543	1650	1007
40'	63	38	130	79	245	149	500	305	760	464	1450	885
50'	56	34	115	70	215	131	440	268	670	409	1270	775
60'	50	31	105	64	195	119	400	244	610	372	1105	674
70'	46	28	96	59	180	110	370	226	560	342	1050	641
80'	43	26	90	55	170	104	350	214	530	323	990	604
90'	40	24	84	51	160	98	320	195	490	299	930	567
100'	38	23	79	48	150	92	305	186	460	281	870	531
125'	34	21	72	44	130	79	275	168	410	250	780	476
150'	31	19	64	39	120	73	250	153	380	232	710	433
175'	28	17	59	36	110	67	225	137	350	214	650	397
200'	26	16	55	34	100	61	210	128	320	195	610	372

Note: When sizing supply lines, consider possibilities of future expansion and increased requirements.  
Refer to National Fuel Gas Code for additional information on line sizing.

Duct furnaces for natural gas are orificed for operation with gas having a heating value of 1000 (±50) BTU per cubic ft. If the gas at the installation does not meet this specification, consult the factory for proper orificing.

**Pipe joint compounds (pipe dope) shall be resistant to the action of liquefied petroleum gas or any other chemical constituents of the gas being supplied.**

Install a ground joint union and manual shutoff valve upstream of the unit control system, as shown in **FIGURE 8**. The 1/8" plugged tapping in the shutoff valve provides connection for supply line pressure test gauge. The National Fuel Gas Code requires the installation of a trap with a minimum 3" (76mm) drip leg. Local codes may require a minimum drip leg longer than 3" (76mm) -- typically 6" (152mm).

Gas connection sizes are listed in **FIGURE 8**. After all connections are made, disconnect the pilot supply at the control valve and bleed the system of air. Reconnect the pilot line and leak-test all connections by brushing on a soap solution.

### WARNING

**All components of a gas supply system must be leak tested prior to placing equipment in service. NEVER TEST FOR LEAKS WITH AN OPEN FLAME. Failure to comply could result in personal injury, property damage or death.**

**FIGURE 8 - Supply Piping Connection**

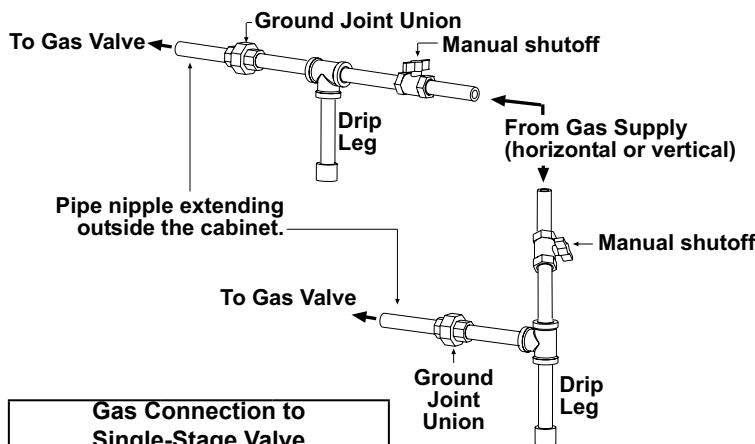

Gas Connection to Single-Stage Valve (Not Gas Supply Line Size)		
Unit Size	75-250	300-400
Natural Gas	1/2"	3/4"
Propane	1/2"	1/2"

**FIGURE 9 - Gas and Electric Connections**

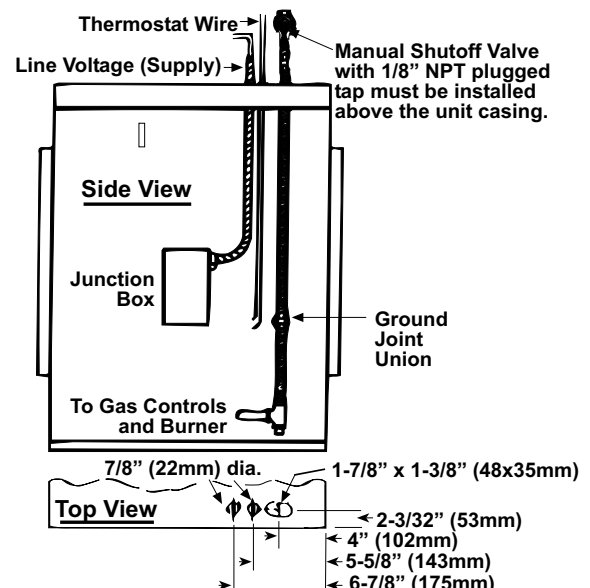



## 6.1.2 Manifold or Orifice Pressure Settings

Measuring manifold gas pressure cannot be done until the heater is in operation. It is included in the steps of the "Check-Test-Start" procedure in Paragraph 9.0. The following warnings and instructions apply.

### WARNING

**Manifold gas pressure must never exceed 3.5" w.c. for natural gas and 10" w.c. for propane gas.**

**For Natural Gas:** When the heater leaves the factory, the combination valve is set so that the outlet gas pressure of a single-stage valve or high fire of a two-stage valve is regulated to 3.5" w.c. Low fire on a two-stage valve is set to 1.8" w.c. Inlet supply pressure to the valve must be a minimum of 5" w.c. or **as noted on the rating plate** and a maximum of 14" w.c. **NOTE: Always check the rating plate for minimum gas supply pressure.** Minimum supply pressure requirements vary based on the size of the burner and the gas control option. Most units require a minimum of 5" w.c. of natural gas as stated above, but Sizes 350 and 400 with electronic modulation require a minimum of 6" w.c. natural gas supply pressure. Sizes 300 and 350 with mechanical modulation require 7" w.c.

**For Propane:** When the heater leaves the factory, the combination valve is set so that the outlet gas pressure of a single-stage valve or high fire of a two-stage valve is 10" w.c. Low fire on a two-stage valve is set to 5" w.c. Inlet pressure to the valve must be a minimum of 11" w.c. and a maximum of 14" w.c.

Before attempting to measure or adjust manifold gas pressure, the inlet (supply) pressure must be within the specified range for the gas being used both when the heater is in operation and on standby. Incorrect inlet pressure could cause excessive manifold gas pressure immediately or at some future time.

#### Instructions to Check Manifold Pressure:

- 1) With the manual valve (on the combination valve) positioned to prevent flow to the main burners, connect a manometer to the 1/8" pipe outlet pressure tap in the valve. **NOTE:** A manometer (fluid-filled gauge) is recommended rather than a spring type gauge due to the difficulty of maintaining calibration of a spring type gauge.
- 2) Open the valve and operate the heater. Measure the gas pressure to the manifold. To measure the low stage pressure on units equipped with a two-stage valve, disconnect the wire from the "HI" terminal on the valve. (Be sure to reconnect wire.)

Normally adjustments should not be necessary to the factory preset regulator. If adjustment is necessary, set pressure to correct settings by turning the regulator screw IN (clockwise) to increase pressure. Turn regulator screw OUT (counterclockwise) to decrease pressure.

Consult the valve manufacturer's literature provided for more detailed information.

**CAUTION: DO NOT bottom out the gas valve regulator adjusting screw. This can result in unregulated manifold pressure causing excess overfire and heat exchanger failure.**

## 6.2 Venting

### DANGER

**Failure to provide proper venting could result in death, serious injury, and/or property damage. This furnace must be installed with a vent connection and proper vent to the outside of the building. Install vent in accordance with Part 7, Venting of Equipment, of the National Fuel Gas Code, ANSI Z223.1 (latest edition) or applicable provision of national, state or local codes. A Canadian installation must be in accordance with the CSA B149.1 and B149.2, Installation Code for Gas Burning Appliances and Equipment, and applicable local codes. Also, comply with venting requirements in this Paragraph. Safe operation of any gravity-vented gas-fired equipment requires a properly operating vent system, correct provision for the combustion air (See Paragraph 2.2) and regular maintenance and inspection. See Hazard Levels, page 2.**

### 6.2.1 Venting Requirements

1. Provide a minimum clearance of 18" between the draft hood relief opening and any obstruction. Do not expose the relief opening to wind drafts from any source such as from an overhead door or adjacent air handling equipment.

## 6.0 Mechanical (cont'd)

### 6.2 Venting (cont'd)

#### 6.2.1 Venting Requirements (cont'd)

2. The unit is equipped with a built-in draft diverter, consequently an external draft diverter **MUST NOT** be installed in the vent connector or any internal alterations made. Do not install a manual damper or other fixed restriction in the vent connector.
3. Vent pipe should be a minimum of 26-gauge galvanized steel or other non-corrosive material. Double-wall, Type B vent pipe such as Metalbestos or Amerivent is recommended. (**NOTE:** Double-wall pipe is not available in 9" diameter.) Where it is necessary to run the vent pipe through an exterior wall of combustible materials, a suitable thimble must be used. The vent pipe shall have a clearance of at least six inches (152mm) from combustible materials or as is specified by the double-wall vent pipe manufacturer.
4. With the outlet on the heater in the horizontal position, it is recommended that a 12-18" (305-457mm) piece of straight pipe be connected to the flue collar before installing an elbow. The horizontal vent pipe run should have a uniform rise of at least 1/4" per foot of horizontal run in the direction of discharge. The length of the lateral run must not exceed lengths shown in the vent tables of the National Fuel Gas Code or the Canadian Installation Code for Gas Burning Appliances (See Vent Tables below).
5. Support horizontal runs every six feet (1.8M). Support vertical runs of type "B" double-wall vent pipe in accordance with the requirements of the pipe manufacturer. Support single-wall vertical pipe in accordance with accepted industry practices. Do not rely on the heater for support of either horizontal or vertical pipes. Use non-combustible supports.
6. Vent connectors serving Category I heaters shall not be connected into any portion of a mechanical draft system operating under positive pressure.
7. Where it is necessary to use a long run of vent pipe, or where the vent pipe is exposed to cold air, condensation within the pipe may occur. There are two ways to overcome or eliminate this problem.
  - (a) Prevent condensation by insulating the pipe so that the temperature of the flue products never drops below 250°F.
  - (b) Use double-wall, Type B vent pipe which is recommended for the reduction or elimination of condensate problems. Where extreme conditions are present and condensate is anticipated, install a trap for collecting condensate.
8. The vent connection may be made into a suitable permanent chimney or into a gas vent. The effective area of the vent connector, gas vent or chimney when connected to a single appliance shall not be less than the area of the appliance drafthood outlet or in accordance with approved venting methods. The effective area of the gas vent or chimney when connected to more than one appliance shall not be less than the area of the largest vent connector plus 50% of the areas of additional vent connectors or in accordance with approved venting methods. Minimum permissible height of the vertical vent is 5 feet (1.5M) providing no horizontal vent pipe connector is used. If a horizontal vent connector is necessary, consult Tables below or the National Fuel Gas Code or the Canadian Installation Code for Gas Burning Appliances, for the maximum permissible length of a horizontal pipe run (vent connector) for a given vertical height of gas vent. The gas vent or chimney should extend at least 3 feet (1M) above the highest point where it passes through a roof of a building and at least 2 feet (.6M) higher than any portion of a building or obstruction within a horizontal distance of 10 feet (3M). Install an Option CC1 vent cap on the end of the vent pipe to prevent rain or snow from entering the open end. (**NOTE:** When installing a Size 125, run the required 7" vent pipe and use a field-supplied increaser to attach an 8" vent cap.)
9. If the heater is installed in a space served by a large exhaust fan, be sure that the exhaust fan does not affect the operation of the heater or the satisfactory venting of its products of combustion.

If a negative pressure exists, as evidenced by a downdraft, a factory-designed mechanical motor drive venter (Option CA) should be installed. In severe negative pressure conditions, makeup air equipment may be necessary.

Vertical Height of the Vent	Vent Diameter													
	5"		6"		7"		8"		9"		10"		12"	
	ft	M	ft	M	ft	M	ft	M	ft	M	ft	M	ft	M
<b>Maximum Horizontal Run for Double-Wall Type B Connector and Double-Wall Type B Vent</b>														
6ft (1.8M)	6	1.8	6	1.8	6	1.8	6	1.8	N/A	6	1.8	6	1.8	
8ft (2.4M)	8	2.4	8	2.4	16	4.9	16	4.9		16	4.9	16	4.9	
10ft (3.0M)	10	3	16	4.9	20	6.1	20	6.1		20	6.1	20	6.1	
15ft (4.6M)	16	4.9	16	4.9	30	9.1	30	9.1		30	9.1	30	9.1	
20ft (6.1M)	20	6.1	30	9.1	30	9.1	30	9.1		30	9.1	30	9.1	
30ft (9.1M)	20	6.1	40	12.2	40	12.2	40	12.2		40	12.2	40	12.2	
<b>Maximum Horizontal Run for Single-Wall Metal Pipe</b>														
6ft (1.8M)	2	0.6	2	0.6	2	0.6	2	0.6	2	0.6	2	0.6	2	0.6
8ft (2.4M)	5	1.5	5	1.5	10	3	10	3	10	3	10	3	10	3
10ft (3.0M)	5	1.5	10	3	15	4.6	15	4.6	15	4.6	15	4.6	15	4.6
15ft (4.6M)	5	1.5	10	3	15	4.6	20	6.1	20	6.1	20	6.1	20	6.1
20ft (6.1M)	-	-	10	3	15	4.6	20	6.1	20	6.1	20	6.1	20	6.1

### 6.2.2 Vent Outlet Size

Model X duct furnaces have the following vent outlet size and shape:

Model Size	75	100	125	150, 175	200, 225	250, 300	350, 400
Size and Configuration of Vent Outlet	5" Round	6" Round	7" Oval	8" Oval	8" Round	10" Oval	12" Oval

### 6.2.3 Power Venting, Option CA

To install a gravity-vented furnace in an area where horizontal venting is required or where negative building pressure inhibits gravity venting, include an optional power venter in the application. Use only a power venter provided by the furnace manufacturer and carefully follow the instructions included in the optional venter package. Use the venter adapter provided to connect the power venter to the heater. **DO NOT INSTALL THE POWER VENTER WITHOUT THE VENTER ADAPTER.**

With an Option CA power venter installed, the furnace may be vented either horizontally or vertically. Do not exceed the maximum vent lengths shown in table. Minimum vent length is 5 ft (1.5M).

**Table Notes:** \* Reduce the vent pipe lengths as follows for each item: 45° Elbow - 7 ft (2.1M); 90° Elbow - 15 ft (4.6M); Option CC1 Vent Cap - 10 ft (3M).

\*\* If the venter outlet is 4", connect a taper-type "enlarger" to the vent outlet when installing 6" vent pipe.

Vent Pipe Diameter	Maximum* Vent Length (ft or M) for Furnace with Optional Power Venter (Option CA)									
		75, 100, 125, 150	175	200	225	250	300	350	400	
4"	ft	100	75	50	35	30	15	N/A		
	M	30	23	15	11	9	4.6	N/A		
6"	ft	N/A					100**	100**	100	92
	M	N/A					30**	30**	30	28

### 6.2.4 Vent Control Damper, Option AV7

**NOTE:** The ignition controller has a safety feature that once it is used with a vent damper, it will no longer operate a unit without a vent damper.



The vent damper option is a motorized damper that will close when the heater is not operating. The vent damper option is applicable only with spark ignition with lockout (Option AH3) and is shipped in a separate box. Follow the manufacturer's instructions to install it in the vent. See the wiring diagram on the heater to make the wiring connections. **NOTE:** The wiring harness with the vent damper is 8 ft (2.4M) in length. The vent damper should be located as close to the heater as possible and cannot be more than 8 ft (2.4M) from the ignition controller.

### 6.3 Duct Furnace Airflow

#### 6.3.1 Pressure Drop and Temperature Rise by Size

To determine temperature rise, the inlet and outlet air temperatures should be measured at points not affected by heat radiating from the heat exchanger. The following chart shows the approved temperature rise range with the required CFM and the internal pressure drop for each size of unit.

## 6.0 Mechanical (cont'd)

## 6.3 Duct Furnace Airflow (cont'd)

### 6.3.1 Pressure Drop and Temperature Rise by Size (cont'd)

Model X - Pressure Drop Table for 80% Thermal Efficient Duct Furnace

Size	75		100		125		150		175		200		225		250		300		350		400	
	Temp Rise	CFM	P.D.	CFM	P.D.	CFM	P.D.	CFM	P.D.	CFM	P.D.	CFM	P.D.	CFM	P.D.	CFM	P.D.	CFM	P.D.	CFM	P.D.	CFM
50°F	1105	0.2	1475	0.4	1840	0.5	2210	0.4	2580	0.5	2945	0.4	3315	0.5	3685	0.4	4420	0.6	5160	0.7	5895	0.7
60°F	920	0.2	1225	0.3	1535	0.3	1840	0.3	2150	0.4	2455	0.3	2765	0.4	3070	0.3	3685	0.4	4300	0.4	4915	0.5
70°F	790	0.1	1050	0.2	1315	0.3	1580	0.2	1840	0.3	2105	0.2	2370	0.3	2630	0.2	3160	0.3	3685	0.3	4210	0.3
80°F	690	0.1	920	0.2	1150	0.2	1380	0.2	1610	0.2	1840	0.2	2070	0.2	2300	0.2	2765	0.3	3225	0.3	3685	0.3
90°F	610	0.0	815	0.1	1020	0.2	1225	0.1	1430	0.2	1635	0.1	1840	0.2	2045	0.2	2455	0.2	2865	0.2	3275	0.2

The duct furnace must be installed on the positive pressure side of the field supplied blower. The air throughput must be within the CFM range stated on the heater rating plate. The air distribution must be even over the entire heat exchanger. Turning vanes should be used in elbows or turns in the air inlet to ensure proper air distribution (See Paragraph 6.3.2).

If it is determined that the blower CFM is greater than allowed or desirable, see Paragraph 6.3.3 for instructions on determining the correct size of bypass duct required or see the **APPENDIX**, page 28, for instructions on converting the furnace for a higher CFM application.

### 6.3.2 Duct Furnace Blower Connections

Proper arrangements of blower and duct furnace with respect to angle of approach of the duct connection and the arrangement of the discharge opening of the blower are shown in **FIGURES 11 A, B, and C**. Blowers should be bottom horizontal discharge when coupled to the duct furnace. If a top horizontal discharge blower is connected to the duct furnace, be sure that sufficient length of duct is provided to permit even flow

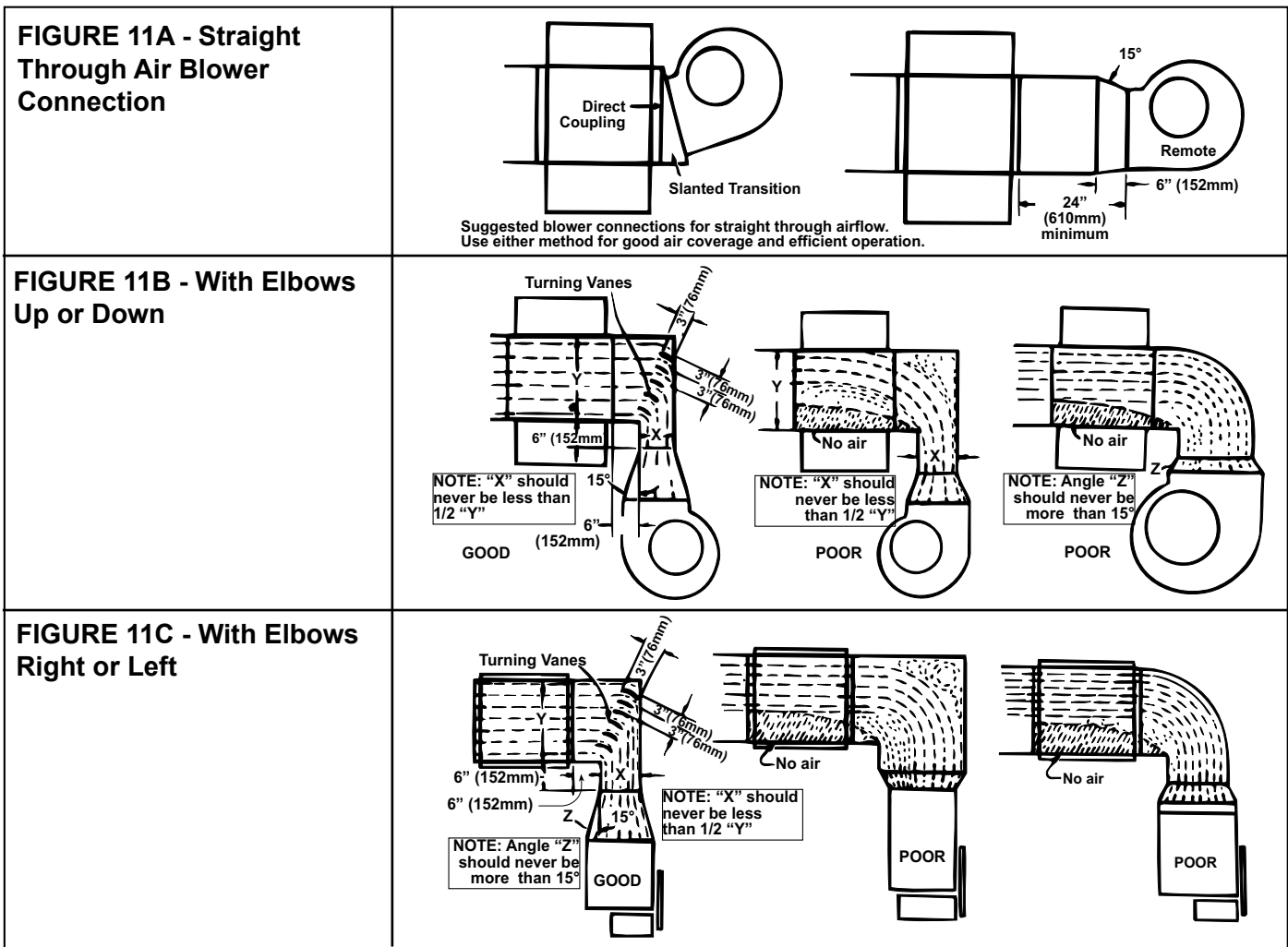

of air at the end of the duct. Or, baffles may be inserted between the blower and the heater to assure an even flow of air across the heat exchanger.

**WARNING**

**The furnace MUST be installed on the positive pressure side of the air-circulating blower. See Hazard Levels, Page 2.**

**6.3.3 Constructing Bypass Duct**

When the CFM of air throughput is greater than desirable or permissible for the unit, a bypass duct may be constructed. Follow these instructions to determine the correct size of the bypass duct.

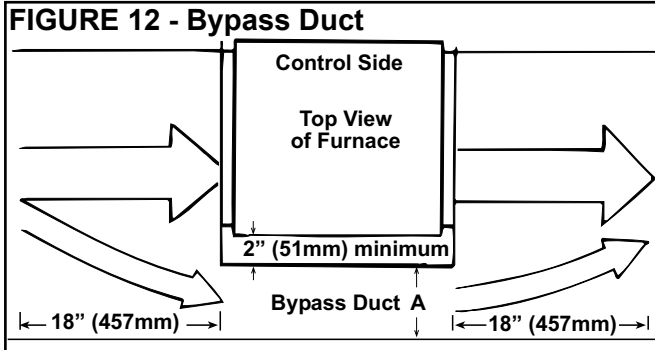

		Bypass CFM								
"A" Width		Pressure Drop through the Furnace								
inches	mm	0.10	0.15	0.20	0.25	0.30	0.35	0.40	0.45	0.50
3"	76	490	530	610	700	780	830	900	960	1010
4"	102	630	750	870	980	1090	1160	1250	1310	1400
5"	127	850	1010	1190	1300	1410	1520	1640	1730	1810
6"	152	1050	1290	1480	1650	1800	1940	2090	2200	2320
7"	178	1250	1510	1760	1960	2180	2320	2500	2650	2800
8"	203	1490	1810	2100	2350	2560	2760	2940	3110	3290
9"	229	1700	2100	2400	2700	2970	3200	3400	3600	3800
10"	254	1920	2350	2760	3090	3650	4020	4300	4550	4800

**Directions for Sizing Bypass Duct**

- 1) From the tables in Paragraph 6.3.1, find the pressure drop (P.D.) and the allowable CFM for the duct furnace that is being installed.  
**EX: Size X150 @ 50°F Temperature Rise; P.D. 38; CFM 2210**
- 2) Subtract the allowable CFM from the actual CFM of the installation to determine how much air must be diverted through the bypass duct.  
**EX: Actual Blower CFM is 3000; 3000 minus allowable CFM of 2210 = 790**
- 3) Go to the column in the bypass CFM chart that is closest to the pressure drop through the heater. Move down in that column until you find the CFM closest to

the answer in Step 2).

**EX: Go to P.D. column .40; move down to 900**

- 4) Move to the left column to find out the required size of the bypass duct.

**EX: Bypass Duct should be 3" (76mm).**

Locate the bypass duct on the side of the furnace opposite the controls and 2" from the heat exchanger side panel. Extend the bypass duct 18" (457mm) beyond the furnace on both the inlet and outlet ends.

**NOTE:** Not all capacities are covered in this chart. If your installation is not covered, consult your factory representative or the factory to determine the appropriate size of the bypass duct.

**6.3.4 Duct Connections**

**FIGURE 13 - Duct Connection Dimensions - inches (mm)**

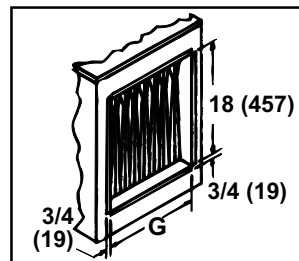

Size	75, 100	125	150, 175	200, 225	250, 300	350	400
G	12-1/2 (318)	15-1/4 (387)	20-3/4 (527)	26-1/4 (667)	34-1/2 (876)	40 (1016)	45-1/2 (1156)

**IMPORTANT NOTE:** A minimum horizontal duct length of 18 inches (457mm) is required at the furnace discharge before any vertical rise is made in front of the draft hood relief opening. This is required to prevent interference with the built-in draft hood.

**Requirements and Suggestions for Connecting and Installing Ducts**

- **Type of Ductwork** - The type of duct installation to be used depends in part on the type of construction of the roof (whether wood joist, steelbar joist, steel truss, pre-cast concrete) and the ceiling (whether hung, flush, etc.).
- **Ductwork Material** - Rectangular duct should be constructed of not lighter than No. 26 U.S. gauge galvanized iron or No. 24 B & S gauge aluminum.
- **Ductwork Structure** - All duct sections 24 inches or wider, and over 48 inches in length, should be cross broken on top and bottom and should have standing seams or angle-iron braces. Joints should be S and drive strip, or locked.

## 6.0 Mechanical (cont'd)

### 6.3 Duct Furnace Airflow (cont'd)

#### 6.3.4 Duct Connections (cont'd)

- **Through Masonry Walls** - No warm air duct should come in contact with masonry walls. Insulate around all air duct through masonry walls with not less than 1/2" (1" is recommended) of insulation.
- **Through Unheated Space** - Insulate all exposed warm air ducts passing through an unheated space with at least 1/2" (1" is recommended) of insulation.
- **Duct Supports** - Suspend all ducts securely from building members. Do not support ducts from unit duct connections.
- **Duct Sizing** - Proper sizing of the supply air ductwork is necessary to ensure a satisfactory heating installation. The recognized authority for such information is the Air Conditioning Contractors Association, 2800 Shirlington Road, Suite 300, Arlington, VA 22206 (www.acca.org). A manual covering duct sizing in detail may be purchased directly from them.
- **Removable Panels** - The ducts should have removable access panels on both upstream and downstream sides of the furnace. These openings must be accessible when the furnace is in service and should be a minimum of 6" x 10" in size so smoke or reflected light may be observed inside the casing to indicate the presence of leaks in the heat exchanger. The covers for the openings must be attached in such a manner as to prevent leakage. See **FIGURE 14A**.
- **Horizontal Discharge Duct Length** - A minimum horizontal duct run of 18" (457mm) is **required** before turns or branches are made in the duct system to prevent interference with the built-in draffhood.
- **Supply Air Duct/Furnace Horizontal Connection** - The seal between the furnace and the duct must be mechanical. Duct connection should be made with "U" type flanges on the top and bottom of the connecting duct. Slide the duct over the flanges of the heater giving an airtight fit. Provide "U" type channels for the other side flanges to ensure tight joints. Use sheetmetal screws to fasten ducts and "U" channels to the furnace flange. See **FIGURES 14A and 14B**.
- **Return Air Duct/Furnace Connection** - All return air ducts should be attached and sealed to return air flanges to provide airtight connection.
- **Return Air Duct/Grill Size** - Make certain that return air ducting or grills have a free area equal to the return duct size connection.

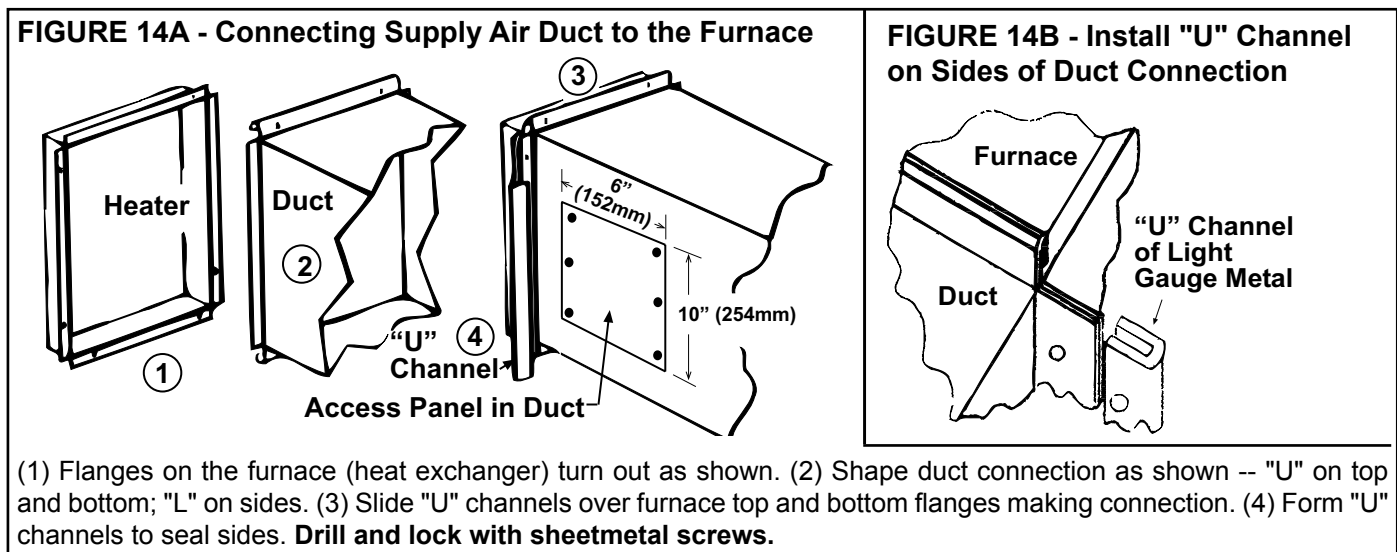

**CAUTION: Joints where ducts attach to furnace must be sealed securely to prevent air leakage into draffhood or burner rack area. Leakage can cause poor combustion, pilot problems, shorten heat exchanger life and cause poor performance. See Hazard levels, Page 2.**

### 6.3.5 Discharge Air Sensor for Makeup Air Application

Makeup air Option AG3 has a unit mounted ductstat with a capillary sensor that is factory-installed in the unit discharge (See Paragraph 8.4.3).

Makeup air Options AG8, AG9, and AG15 require field installation of the sensor in the discharge ductwork. Option AG15 uses the box and sensor holder in **FIGURE 15A**. Options AG8 and AG9 include a sensor and mixing tube as illustrated in **FIGURE 15B**. Follow the instructions below to install the sensor in the ductwork.

For control information, see Paragraph 8.4.

#### Instructions for Installing Discharge Air Sensor in the Ductwork

**FIGURE 15A - Discharge Air Sensor Holder, P/N 115850, used in Makeup Air Option AG15**



Secure sensor in clip. Position holder so that it shields sensor from direct airflow.

**FIGURE 15B - Discharge Air Sensor and Mixing Tube used in Electronic Modulation Options AG8 and AG9**



1. Depending on the option, the sensor will be as shown in either **FIGURE 15A** or **15B**. See Paragraph 3.2 for a list of shipped-separate components by option.
2. Determine a location in the ductwork to install the sensor.

Select a location a sufficient distance from the outlet to provide a good mixture of discharge air temperature. According to the latest edition of AMCA Standard 201, in straight ducts, the air is typically well mixed a minimum of five equivalent duct diameters from the discharge of the unit with equivalent duct diameter defined as equal to the square root of  $4AB/3.14$ . "A" and "B" are the duct cross-sectional dimensions.

**Example:** Supply ductwork cross-sectional dimension is 24" x 12" (610mm x 305mm).

$$5 \times \sqrt{\frac{4 \times 12 \times 24}{3.14}} = 96" \quad 5 \times \sqrt{\frac{4 \times 305 \times 610}{3.14}} = 2435\text{mm}$$

**Solution:** Locate the sensor a minimum of 96" (2435mm) from the outlet of the unit.

**NOTE:** If the length of the discharge duct is less than 8 ft (2.4M), a mixing vane is recommended for mixing the discharge air.

Do not mount the sensor in the ductwork after a split in the supply as that will cause loss of control in the duct that does not house the sensor.

3. The position of the sensor holder or mixing tube is important. The holder in **FIGURE 15A** will extend 9-3/16" (233mm) into the ductwork. The mixing tube in **FIGURE 15B** is 12" (305mm) long.

In horizontal ductwork, locate the sensor assembly in the top, middle of the duct with the sensor probe extending vertically down into the center of the airstream.

In vertical ductwork, locate the sensor assembly in the middle of the side of the duct that corresponds with the top middle of the discharge outlet.

Turn the holder so that the element will be shielded from direct airflow and will sense the air temperature as it flows through the holes in the holder.

At the selected location in the ductwork, mark the diamond-shaped hole [approximately 1" x 1" (25mm x 25mm)] required for the sensor holder or the round hole needed for the mixing tube. Cut the hole no larger than required.

4. **Option AG15** - Push the element into the clip in the holder. Determine where the sensor wire should enter the box and remove the knockout. Slide the holder into the ductwork. Using four field-supplied No. 6 sheetmetal screws, attach the box portion of the holder to the ductwork. Attach a field-supplied cable connector to the box, connect the sensor wire, and attach the box cover.

**Options AG8 and AG9** - Slide the mixing tube into the ductwork and attach the sensor. Connect the wires as shown on the wiring diagram.

## 7.0 Electrical Supply and Wiring

### 7.2 Supply Voltage and Wiring

---

**CAUTION: If any of the original wire as supplied with the appliance must be replaced, it must be replaced with wiring material having a temperature rating of at least 105°C, except for limit control, energy cutoff, and sensor lead wires which must be 150°C.**

---

### 7.3 Thermostat and Control Wiring

## 7.1 General

All electrical wiring and connections, including electrical grounding MUST be made in accordance with local, state and national codes and regulations and with the National Electric Code ANSI/NFPA No. 70 (latest edition) or, in Canada, the Canadian Electrical Code, Part I-C.S.A. Standard C22.1. In addition, the installer should be aware of any local ordinances or gas company requirements that might apply.

Check the rating plate on the heater for the supply voltage and current requirements. Run a separate line voltage supply with fused disconnect switch directly from the main electrical panel to the furnace, making connection to leads in the junction box. All external wiring must be within approved conduit and have a minimum temperature rise of 60°C. Be sure conduit from the disconnect switch will not interfere with the service panels of the furnace.

If the heater has field-installed options that require electrical connections, consult the instruction sheet and wiring diagram supplied in the option package.

Specific wiring diagrams that include standard and factory-installed options are included with the heater. **Typical wiring diagrams of currently manufactured heaters are on pages 17-18.**

#### Disconnect Switch

A disconnect switch is a required part of this installation. Switches are available, as options or parts, or may be purchased locally. When ordered as an optional component, the disconnect switch is shipped separately.

The disconnect switch may be fusible or non-fusible. When providing or replacing fuses in a fusible disconnect switch, use dual element time delay fuses and size according to 1.25 times the maximum total input amps.

When installing, be careful that the conduit and switch housing are clear of furnace panels and inspection plates. Allow at least four feet (1.2M) of service room between the disconnect switch and removable panels.

A thermostat is not standard equipment but is an installation requirement. Use either an optional thermostat available with the heater or a field-supplied thermostat. Install according to the thermostat manufacturer's instructions.

A 24-volt thermostat must be used to actuate low voltage gas controls. If line voltage from the thermostat to the unit is desired, consult the factory representative.

Wiring between the thermostat and the heater must be suitable for a temperature rise of 60°C. Labeled thermostat leads are provided in the heater junction box for connection of thermostat wiring.

Thermostats should be located five feet (1.5M) above the floor on an inside wall, not in the path of warm or cold air currents and not in corners where air may be pocketed. Do NOT install a thermostat on cold air walls. For specific connection details, refer to the instructions with the thermostat.

If more than one unit is cycled from one thermostat, separately activated relays must be substituted at unit thermostat connections.

---

**CAUTION: Make sure the thermostat has an adequate VA rating for the total requirements. Add coil rating of all relays and match thermostat rating. See Hazard Levels, page 2.**

---

24 Volt Controls - Maximum Amps			
(24 volt Transformer has 20 VA capacity)			
Single-Stage Valve	.7A	Fan Control Heater	.12A
Two-Stage Valve	.33A	Time Delay Relay	.1A
Maxitrol System	.5A	Heater	
Spark Ignition	.1A	Relay Coil	.12A

If the low voltage (24 volt) thermostat is equipped with a heat anticipator to level out unit cycling for optimum temperature control, set the anticipator at full load control AMPS.



## 7.4 Typical Wiring Diagrams

**NOTE:** If a wiring diagram is needed for a Model X with a match lit pilot (manufactured prior to 10/03), see **APPENDIX**, page 30.

**FIGURE 16 - Typical Wiring Diagram for Model X Furnace with Spark Pilot and Single-Stage Gas Valve**

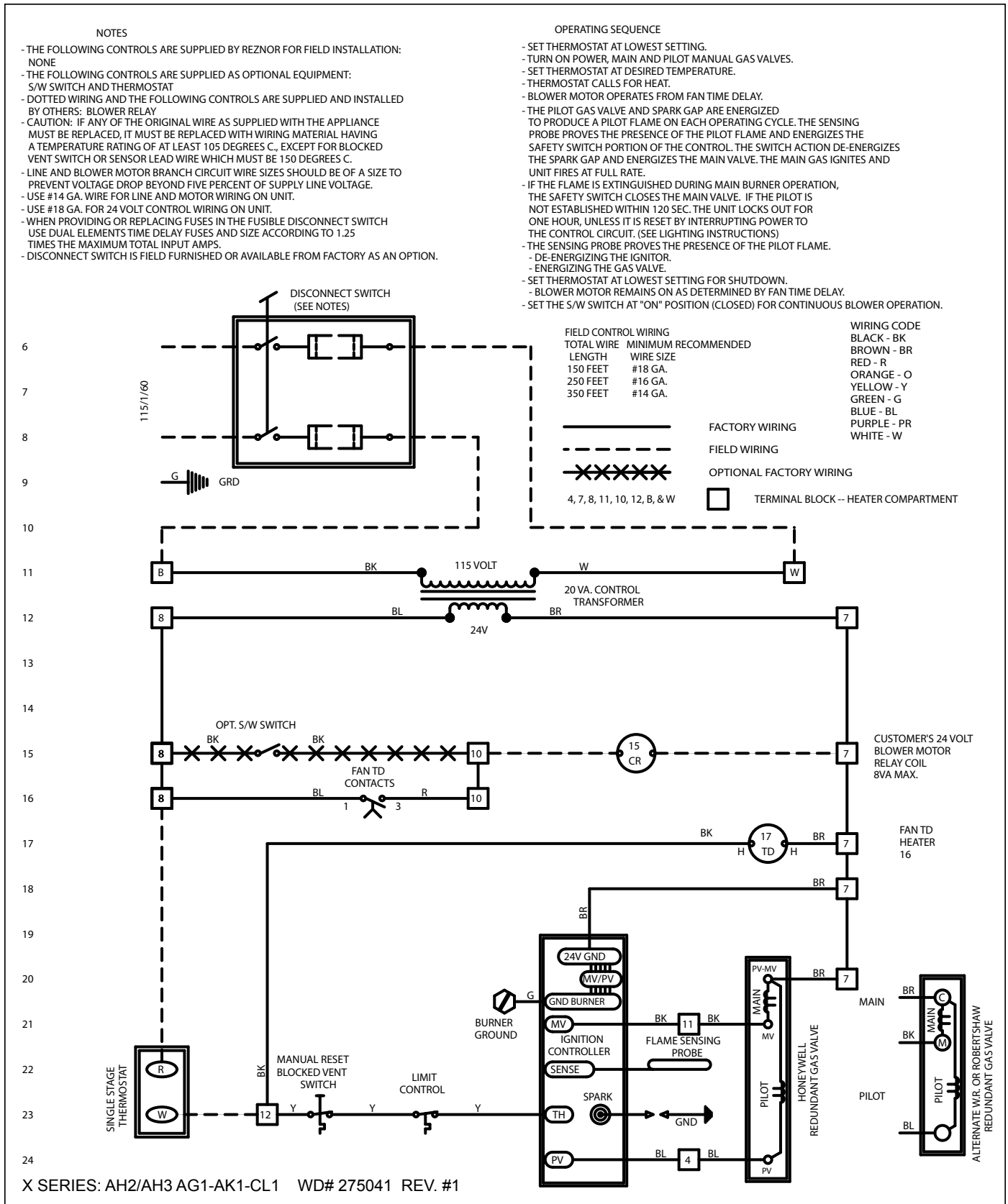

# 7.0 Electrical Supply and Wiring (cont'd)

## 7.4 Typical Wiring Diagrams (cont'd)

FIGURE 17 - Wiring Diagram for Model X Furnace with Spark Pilot and Two-Stage Gas Valve

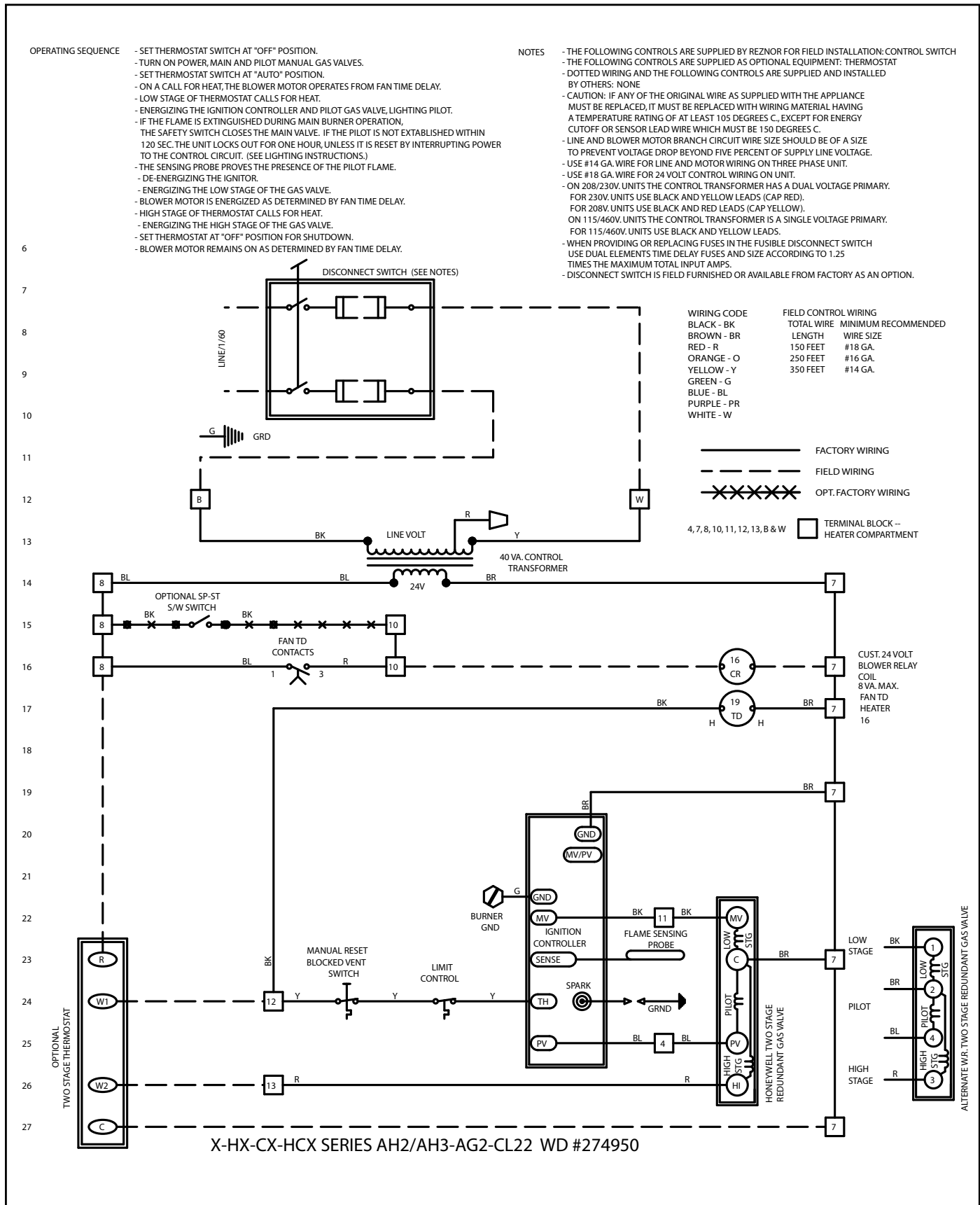

## 8.0 Controls

### WARNING

If you turn off the power supply, turn off the gas. See Hazard Levels, Page 2.

## 8.1 Fan Control

1. A fan control provides for the following control of the field-supplied blower.
  - (a) After the gas valve opens, there is a time delay of blower operation to prevent the discharge of cold air.
  - (b) Blower operation continues after the thermostat is satisfied as determined by the fan time delay.
2. To be sure that the blower can continue to operate, the power supply to the furnace **MUST NOT** be interrupted **except** when servicing the unit.
3. If the customer wants the furnace off at night, the gas valve circuit **SHOULD BE OPENED** by a single pole switch wired in series with the thermostat. Some thermostats are provided with this feature. Multiple units controlled from a single thermostat are shut off in the same manner. For proper operation, be sure the fan control wiring is observed.

**Service NOTES:** To replace the fan control on units manufactured prior to 11/2004, a replacement kit is required. Order P/N 209184. Prior to 10/2003, the fan control was optional. Check the wiring diagram on the furnace.

## 8.2 Limit Control

The heater is equipped with a non-adjustable high limit switch which shuts off the gas in the event of motor failure, lack of air due to dirty filters, or restrictions at the inlet or outlet of the unit. See Paragraph 9.3 for limit control check.

## 8.3 Blocked Vent Switch

The blocked vent switch is a heat-activated, manually reset, safety device that interrupts the electric supply to the gas valve when the vent is 100% blocked. The sensor is located near the relief opening of the draffhood. The reset button is located inside the control compartment by the draffhood side.

If the sensor detects heated flue gases in the draffhood relief opening area, the blocked vent safety device will activate to shut down the furnace. The cause of the switch shutting down the furnace must be determined and corrected. The blocked vent switch is designed to activate when the vent is blocked but may also be affected by a negative building pressure or an inadequate vent system.

After the problem has been corrected, remove the furnace control compartment panel and push the manual reset button on the blocked vent switch to restart the heater. Replace the panel.

### WARNING

In the event the blocked vent sensor causes the heater to shutoff, determine the correct the cause. Failure to do so could result in personal injury or death.

## 8.4 Gas Controls

### 8.4.1 Gas Valve

All furnaces are equipped with a 24-volt combination valve which includes the automatic electric on-off valve controlled by the room thermostat, the pressure regulator, and the manual shutoff valve. The standard gas valve allows for single-stage control from a single-stage, 24-volt thermostat.

### WARNING

The operating valve is the prime safety shutoff. All gas supply lines must be free of dirt or scale before connecting the unit to ensure positive closure.

### 8.4.2 Optional Two-Stage Operation for Heating Only

The standard combination control valve is replaced with a two-stage combination gas control valve providing for low fire or high fire operation controlled by a two-stage thermostat. First stage (low fire) is factory set (not field adjustable). Both high and low stages are controlled by a Servo regulator, maintaining constant gas input under wide variations in gas supply pressure. See instructions packed with the unit for specific gas valve specifications, wiring, and operating instructions.

### 8.4.3 Optional Two-Stage Operation for Makeup Air

Two-stage makeup air units are equipped with a two-stage gas valve, but instead of control from a two-stage room thermostat, the outlet air temperature is monitored and controlled by a two-stage ductstat. When the discharge air temperature drops to the setpoint, low fire is energized. If low fire cannot satisfy the ductstat setting, high fire is energized.

## 8.0 Controls (cont'd)

### 8.4 Gas Controls (cont'd)

#### 8.4.3 Optional Two-Stage Operation for Makeup Air (cont'd)

Makeup air applications are usually adjusted to discharge an outlet air temperature between 65°F and 75°F. In all applications, the allowable temperature rise of the furnace in the installation dictates the limits of the ductstat temperature setting.

Depending on the option selection, the sensor is either connected by capillary tubing to the unit-mounted ductstat (FIGURES 18 and 19) or electrically connected to a remote electronic temperature selector (FIGURE 20). See Paragraph 6.3.5 for instructions on locating the sensor in the ductwork.

**Optional Ductstat with Capillary Tubing (FIGURE 18)** - The control is set to 70°F and has an adjustable range with a fixed differential of 2-1/2°F. Due to different CFM settings and outside air temperatures, the average downstream outlet temperature may not match the ductstat setting exactly. After the installation is complete, adjust the setpoint of the ductstat to achieve the desired average discharge air temperature.

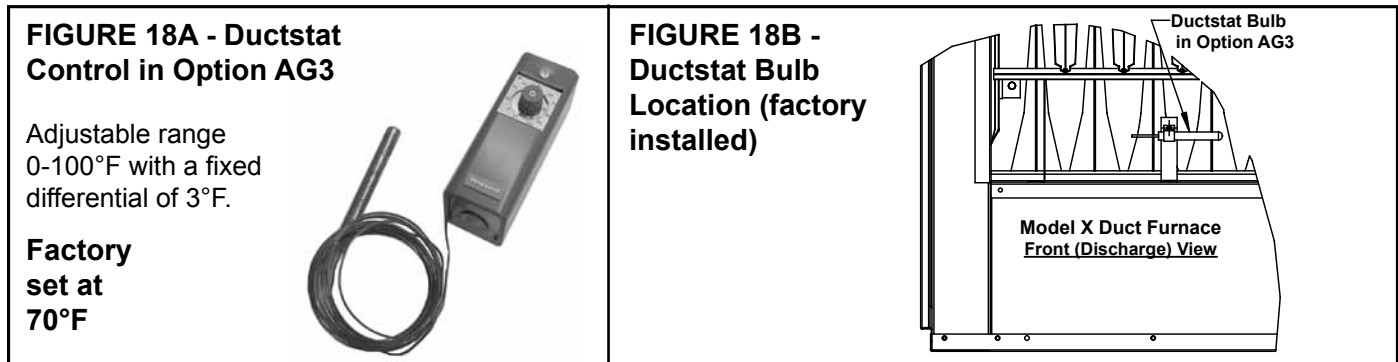

**FIGURE 19 - Ductstat Control in Two-Stage Makeup Air Control Option AG15 - (A) Remote Temperature Selector; (B) Stage-Adder Module**



**Optional Ductstat with Electronic Remote Setpoint Module (Option AG15)** - The sensing probe is field-wired to a remote temperature selector. The temperature selector has an operating range to 120°F. The remote modules are shipped separately for field installation.

Follow the wiring diagram with the unit and the manufacturer's instructions for wiring and installation. There will be one module for selecting temperature and one-stage adder module as illustrated in FIGURE 20.

**CAUTION: Be sure heat/cool selector switch is set at "Heat" position.**

#### 8.4.4 Optional Electronic Modulation

**FIGURE 20A - Amplifier in Options AG7, AG8, and AG9**



The type and capability of the electronic modulation system depends on the option selected. Electronic modulation options are identified by a suffix to the Serial No. printed on the heater rating plate. AG7 is identified as MV-1; AG8 is identified as MV-3; AG9 is identified as MV-4; and AG21 is identified as MV-A.

**Electronic Modulation between 50% and 100% Firing Rate (Options AG7, AG8, AG9)** - Depending on the heat requirements as established by the thermistor sensor, the burner modulates between 100% and 50% firing. The thermistor is a resistor that is temperature sensitive in that as the surrounding temperature changes, the Ohms resistance changes through the thermistor. This change is monitored by the solid state control center (amplifier) which furnishes varying DC current to the modulating valve to adjust the gas input.

Each modulating valve is basically a regulator with electrical means of raising and lowering the discharge pressure. When no DC current is fed to this device, it functions as a gas pressure regulator, supplying 3.5" w.c. pressure to the main operating valve.

Refer to the wiring diagram supplied with the furnace for proper wiring connections. Electronic modulation for heating controlled by a specially designed room thermostat (60°-85°F) is identified as Option AG7. Electronic modulation control systems for makeup air applications controlled by a field-installed duct sensor (See Paragraph 6.3.5.) and temperature selector (55-90°F) are identified as either Option AG8 or Option AG9. The temperature selector setting for Option AG8 is on the amplifier; Option AG9 has a remote temperature selector. Both systems are available with an override thermostat.



**FIGURE 20B - Signal Conditioner in Option AG21**

**Computer Controlled Electronic Modulation between 50% and 100% Firing Rate (Option AG21)** - With this option the furnace is equipped with a Maxitrol signal conditioner which operates much the same way as the amplifier above to control the regulator valve. The conditioner accepts an input signal of either 4-20 milliamps or 0-10 volts from a customer-supplied control device such as a computer. With the dip switches on the conditioner in the "on" positions, the conditioner accepts a 4-20 milliamp signal. In the "off" positions, the conditioner accepts a 0-10V signal. The conditioner converts the signal to the 0 to 20 volt DC current required to control the modulating valve.

## 8.5 Pilot and Ignition Systems

Model X furnaces have an intermittent spark pilot system. The horizontal pilot is located in the control end of the burner rack and is accessible after the control compartment panel has been removed. All pilots are target type with lint-free feature. Pilot gas pressure should be the same as supply line pressure. (See Paragraph 6.1.) If required, adjust the pilot flame length to approximately 1-1/4" with pilot adjustment screw in control valve body.

**Service NOTE:** If your Model X heater was manufactured prior to 10/2003, it may have a standing pilot. See wiring diagrams in the **APPENDIX**, page 30.

**Spark Ignition Safety Pilot System** - Natural gas units are equipped with a spark ignited intermittent safety pilot system that shuts off the pilot gas flow between heat cycles. Propane units (or as an option on natural gas units) require a lockout device. The lockout device stops the gas flow to the pilot if the pilot fails to light in 120 seconds. The lockout feature has a one hour retry and requires manual set by interruption of the thermostat circuit. Refer to the wiring diagram supplied with the unit for pilot system identification and proper wiring. Pilot with lockout is Option AH3; spark pilot without lockout is Option AH2.

**FIGURE 21 - Burner Rack with Spark Pilot**

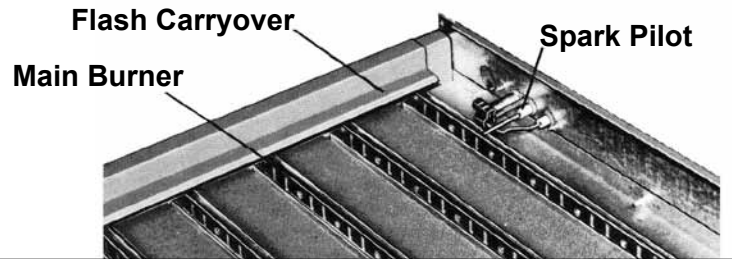

**Ignition Controller** - As part of the intermittent safety pilot systems, the ignition controller provides the high voltage spark to ignite the pilot gas and also acts as the flame safety device. After ignition of the pilot gas, the ignition controller electronically senses the pilot flame. A low voltage DC electrical signal is imposed on the separate metal probe in the pilot assembly. The metal probe is electrically insulated from ground. The pilot flame acts as a conduction path to ground completing the DC circuit and proving pilot flame. **Proper operation of the electronic spark ignition system requires a minimum flame signal of .2 microamps as measured by a microammeter.** With pilot flame proven, the ignition controller energizes the main gas valve.

**FIGURE 22 - Ignition Controllers**



**Ignition Controller with Lockout, UTEC 1003-514, P/N 257010, for Option AH3 Gas Control**



**Recycling Ignition Controller, UTEC 1003-638A, P/N 257009, for Option AH2 Gas Control**

**Service NOTE:** If replacing an earlier style of ignition controller, order replacement kit **P/N 257472** for a unit with recycling gas control Option AH2 or **P/N 257473** for Option AH3 gas control with lockout. (Option codes are listed on the unit wiring diagram.)

Use of an optional vent damper requires an ignition controller with lockout.

## 8.0 Controls (cont'd)

## 8.5 Pilot and Ignition Systems (cont'd)

**NOTE:** When checking for spark with the pilot burner assembly removed from the burner rack, the pilot assembly must be grounded to the heater for proper spark.

### FIGURE 23 - Spark Pilot -- Maintain a spark gap of 7/64"

**CAUTION:** Due to high voltage on pilot spark wire and pilot electrode, do not touch when energized. See Hazard Levels, page 2.

If no spark occurs, check the following:

- Voltage between Terminals TH and 7 should be at least 20 volts and no higher than 32 volts. Refer to Troubleshooting (Paragraph 10.3) if no voltage is observed.
- Short to ground in the high tension lead and/or ceramic insulator.
- Pilot spark gap should be approximately 7/64".

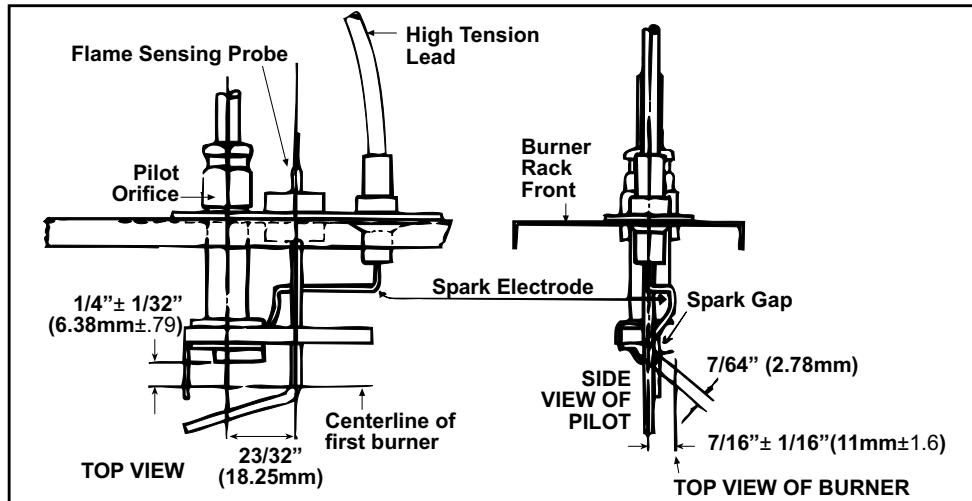

If the above conditions are normal and no spark occurs, replace the ignition controller. If the main gas valve fails to open with a normal full size pilot flame established, check for the following:

- Voltage between black and brown leads on the main gas valve is 20 to 32 VAC and there is no main gas flow with the built-in manual valve in FULL OPEN position -- the main valve is defective.
- No voltage between black and brown leads on the main gas valve -- check for disconnected or shorted flame sensor lead or flame sensor probe.

When the above conditions are normal and the main gas flow is still off, the ignition controller is probably defective.

**NOTE:** Model X furnaces manufactured prior to 10/2003 may be equipped with a match-lit pilot.

## 8.6 Burner Carryover System and Air Adjustment

### 8.6.1 Burner Carryover

These duct furnaces have individually formed steel burners with accurately die-formed ports to give controlled flame stability without lifting or flashback with either natural or propane gas. The burners are lightweight and factory mounted in an assembly which permits them to be removed as a unit for inspection or service.

All natural gas burners are equipped with two flash carryover systems that receive a supply of gas simultaneously with the main burner. All propane gas burners are equipped with one flash carryover and a regulated gas lighter tube system. During regular service, check the main burner ports, the carryover assemblies, and the orifices for cleanliness.

### 8.6.2 Burner Air Adjustment

Burner air shutters are not normally required on natural gas furnaces. Air shutters are required on propane gas units and may require adjustment.

Before making any adjustments to the air shutters, allow the heater to operate for about fifteen minutes with the air shutters open. The slotted screw on the end manifold bracket moves the air shutters and adjusts all burners simultaneously. Turning the screw clockwise opens the shutters; counterclockwise closes the shutters. After the furnace has been in operation for 15 minutes, close the air shutters observing the flame for yellow-tipping. Open the shutters until the yellow disappears. A limited amount of yellow-tipping is permissible for liquefied petroleum gases. Natural gas should not display any yellow-tipping.

When making the adjustment, close the air shutters no more than is necessary to eliminate the problem condition.

**DANGER:**

**Failure to install and/or adjust air shutters according to directions could cause property damage, personal injury, and or death.**

## 9.0 Commissioning and Startup

### 9.2 Startup

**NOTE:** Prior to 8/2008, a Model X unit could have an intermittent spark system without lockout, Option AH2. Check the wiring diagram on the furnace.

### 9.3 Check installation after startup

### 9.1 Check the installation prior to startup

- Check suspension. Unit must be secure and level.
- Be certain the electrical supply matches voltage rating of the furnace. (Refer to the rating plate.)
- Check clearances from combustibles. Requirements are shown in Paragraph 4.2.
- Check vent system to be sure that it is installed according to the instructions in Paragraph 6.2. Be sure that flue discharge openings are free from obstructions.
- Check piping for leaks and proper gas line pressure. Bleed gas lines of trapped air. See Paragraph 6.1.
- a) Turn manual shutoff valve to off position.
- b) Turn gas supply on.
- c) Observe gas meter for movement, or
- d) Attach pressure gauge readable to .1" w.c. and after turning gas on for 10 seconds, turn the gas off. No change in pressure should occur over a 3-minute period.
- e) If either c) or d) above indicate a leak, locate leak by brushing a soapy solution on all fittings. Bubbles will appear at a leak. Repair and repeat tests.
- Turn electric and gas supply on to the furnace. Adjust the thermostat or ductstat so that a call for heat exists. Observe for complete sequencing of pilot and ignition.

#### Operating Sequence for Intermittent Spark Pilot System

- 1) Set the thermostat switch at its lowest setting.
- 2) Follow lighting instructions.
- 3) Set thermostat switch at desired setting.
- 4) Thermostat calls for heat, energizing the ignition controller and the pilot gas valve, lighting the pilot. **NOTE:** If the flame is extinguished during main burner operation, the safety switch closes the main valve and recycles the spark gap. If pilot is not established within 120 seconds (approx.), the unit locks out. At 60-minute intervals, the controller will retry to establish pilot or may be reset at any time by interrupting the power to the control circuit (See Lighting Instructions).
- 5) The sensing probe proves the presence of the pilot flame.  
(a) De-energizing the ignitor; (b) Energizing the gas valve.
- 6) Blower motor operates from fan time delay.
- 7) Set the thermostat switch at lowest setting for shutdown. Blower motor remains on as determined by fan time delay.

- With the unit in operation, measure manifold gas pressure. Manifold pressure for natural gas should be 3.5" w.c. and 10" w.c. for propane gas. See Paragraph 6.1.
- Turn the unit off and on, pausing two minutes between each cycle. Observe for smooth ignition. On two-stage or modulating burner systems, manipulate temperature adjustment slowly up and down to see if control is sequencing or modulating properly. Raising temperature setting drives burner on or to full fire.
- Observe burner flame at full fire. Natural gas flame should be about 1-1/2" in height with blue coloring. Propane gas flame should be approximately the same length with blue coloring. Yellow tipping may appear on propane gas. If yellow extends beyond 1/2 to 3/4", adjust air shutters. See Paragraph 8.6.2.