NORDSTROM

400-D HYDRAULIC HAND GUN

**Assembly, Operation and
Maintenance Manual**



FLOWSERVE

Nordstrom Valves

Contents

Nordstrom Valve Sealants2

Functions of Nordstrom Valve Sealants2

400-D Hydraulic Hand Gun3

Operation.....4

Kits and Accessories5

Parts List6 & 7

Illustrations6 & 7

Care and Maintenance.....8 – 10

Troubleshooting Guide11

Customer Assistance.....12

Nordstrom Valve Sealants

At Nordstrom Valves, Inc. our primary goal is to serve lubricated valve users with the highest quality sealant and sealant injection equipment.

We offer:

- A broad variety of valve sealants
- A flexible, service-oriented manufacturing facility providing outstanding quality
- An experienced, dedicated staff ready to serve your needs

Nordstrom Valves, Inc. success comes from customer service. Competent, experienced personnel handle your orders from development ... to order entry ... to manufacturing ... to shipping.

We supply the most advanced formulations. Our high quality sealants range from -85°F to 700°F (-65°C to 371.1°C) ... and from air and water applications to the most aggressive line fluids.

Functions of Nordstrom Valve Sealants

1. **Drop-Tight Seal** - To secure an absolutely tight seal, the film of the sealant works to form a seal between the sealing surfaces of the valve. The seal is formed by sealant transmitted through a system of passageways around the valve ports. With proper selection of sealant for your particular service, a seal can be retained over a wide range of temperatures and pressures.
2. **Lubrication** - Prevents metal-to-metal contact of the valve sealing surfaces by filming over irregularities. No matter how finely ground a metal surface may be, the metal is a series of tiny peaks and valleys. As one metal surface slides against another, friction is set up and adhesion, shearing, or plowing may result. A protective film of sealant between the bearing surfaces prevents metal-to-metal rubbing.
3. **Renewable Seat** - There is no need to disassemble a lubricated valve or remove it from service to replace mildly damaged seats. Sealant, as a structural part of lubricated valves, provides a flexible and renewable seat, eliminating the

necessity of force fit contact to effect a seal. For this purpose, the sealant not only must have proper plasticity, but also resistance to line fluids such as solvents and chemicals. Sealant forms a seal between the sealing surfaces of the valve even under pressure.

4. **Plug Jacking** - The fundamental operating principle of the traditional lubricated plug valve design lies in the application of Pascal's Law. The law states that a unit of pressure applied to the liquid contained in a sealed vessel is transmitted to every part of the liquid with undiminished force, thus multiplying the force many times, depending on the area of the interior of the vessel. The sealant, under pressure developed by sealant injection, supplies the hydraulic means for lifting the plug from its tapered seat when and if that force is needed to free the plug for easier operation.

400-D Hydraulic Hand Gun

The Nordstrom 400-D High-Pressure Hand Gun is rated at 10,000 - 11,000 psi (690 - 759 bar) and includes many features for meeting the exact demands of replacing sealant in lubricated valves.

One of the most outstanding features is the 400-D gun's large fluid capacity which permits long periods of operation between recharging.

In the 400-D Hand Gun, any air entrapment is eliminated by adding fluid when recharging, which automatically purges the system of air. The gun operates effectively in all positions.

The floating piston in the gun is solid. There is no cap screw to cause fluid leakage and eventual operation failure.

By using a special-formula hydraulic fluid in the pumping mechanism, the gun pumps smoothly and with minimum effort. Its powerful hydraulic floating piston principle forces sealant out of the gun with ease regardless of the sealant viscosity.

The 400-D Hand Gun is equipped with a Giant Button Head Coupler for connection to the button head sealant fitting of the valve. This coupler has a design feature which locks it to the sealant fitting when the gun is under positive pressure. The coupler cannot be connected to, or separated from the fitting with the gun under pressure.

Due to the "built-in" safety features, the 400-D Hand Gun provides maximum safety both to the user and the gun itself. The hydraulic system of the gun is equipped with an internal relief valve to protect the operator if pumping continues after the gun is depleted of sealant.

The internal relief valve is tamperproof and is relatively unaffected by temperature change and relieves approximately the same pressure at temperatures between 0°F (-18°C) and 80°F (27°C) assuring maximum pump output throughout the variation.

A pressure gauge indicates the point at which sufficient sealant pressure has been developed within the valve.

In designing the 400-D Hand Gun, engineers concentrated on greatly simplifying maintenance and repair procedures. In most cases, the gun can be easily maintained and repaired by valve service personnel, without requiring factory service.



Operation

Preparing the 400-D Hand Gun for Use

The 400-D Hand Gun is packaged with the Sealant Barrel Cap and hose assembly separate from the gun. To make the 400-D Hand Gun operational, all you need to do is load the gun with sealant and attach the cap and hose assembly. Refer to the **Nordstrom Sealant Brochure** for information on the sealant required for your specific valve application.

Loading the 400-D Hand Gun with Sealant

The 400-D Hand Gun is capable of pumping all viscosities of valve sealants. The barrel is designed to accept a size "J" sealant stick (1.50" diameter x 8.75" length). Bulk grade sealants can be manually loaded into the gun or by using Nordstrom Gun Pak. For Gun Pak, insert the heat-sealed end of the bag first.

CAUTION: The 400-D Hand Gun is a hydraulic hand gun capable of developing high pressures. The following operating instructions should be read and followed closely to assure the safe and proper use of the equipment.

Note: Numbers in parentheses refer to gun parts as illustrated on pages 6 and 7.

1. "Crack" the By-Pass Valve (12) by turning counter-clockwise less than one full turn. It should not be tightened against the By-Pass Stop (14). Backing out the By-Pass Valve too far will allow air to enter the hydraulic system of the gun.
2. Remove the Sealant Barrel Cap (26), complete with hose assembly, using the Handle with Grip (1). The Handle is detachable and has a hole drilled near one end. By unscrewing the Handle and placing the hole over the protruding pin on the Sealant Barrel Cap, the cap may be easily removed and replaced.
3. Using the Handle as a push rod, return the Floating Piston (41) to the bottom of the Sealant Barrel (24).
4. Clean and replace the Handle.
5. Close the By-Pass Valve. Do not jam the By-Pass Valve in to the seat as this may damage the sealing member.
6. Insert the J-Stick or Gun Pak (heat sealed end first) into the Sealant Barrel.
7. Operate the gun until the J-Stick or Gun Pak protrudes approximately 1/4" (6 mm) from the end of the Sealant Barrel.
8. Replace the Sealant Barrel Cap and tighten snugly using the Handle.
9. Before attaching the Giant Button Head Coupler (44) to the valve sealant fitting, operate the gun until resistance is felt or the gun begins to build pressure (the hose will stiffen). Continue to pump until internal relief valve releases and note the pressure at which this occurs.
10. Crack the By-Pass Valve to relieve pressure and close again. The 400-D Hand Gun is now ready for servicing lubricated valves.

Lubricating Valves with the 400-D Hand Gun

1. Slide the Giant Button Head Coupler (44) over the button head fitting on the valve to be injected with sealant.
2. Tighten the By-Pass Valve (12).
3. Begin sealant injection by pumping the gun Handle (1). It may take a number of strokes for the gun to prime itself and inject sealant into the valve.
4. As the valve sealant system becomes full, the gun should become harder to operate and a pressure drop noted on the gauge. When the valve is full of sealant, open the By-Pass Valve and disengage the Giant Button Head Coupler. (Hydraulic pressure must be removed from the gun before the coupler can be removed.)

Caution: Do not continue pumping the gun after the sealant barrel has been emptied of sealant as the Floating Piston Assembly may be damaged or the Gun Pak bag may be pumped into the hose.

Hint: To retain most of the hydraulic pressure in the gun when removing from a valve, quickly "crack" open and close the By-Pass Valve. This will relieve enough hydraulic pressure to allow for easy removal of the coupler but maintain enough pressure to keep from re-priming the gun between valves.

Kits and Accessories

Major Repair Kit #1900028

| Qty. | Part Number | Part Description |
|------|-------------|---|
| 1 | 47524 | Button Head Coupler Repair Kit |
| 1 | 60040 | Hydraulic Pump with Piston 60041 & O-Ring 934005 |
| 1 | 60048 | By-Pass Valve |
| 1 | 60059 | Check Valve Assembly |
| 1 | 70960M | Hydraulic Fluid Bag |
| 1 | 71251 | Hydraulic Fluid (1 pint can) |
| 2 | 1900011 | Nylon Cup |
| 1 | 1900027 | Minor Repair Kit |
| 1 | 934006 | O-Ring |
| 1 | 908705 | Screw |

Minor Repair Kit #1900027*

| Qty. | Part Number | Part Description |
|------|-------------|------------------|
| 1 | 934003 | O-Ring |
| 1 | 934005 | O-Ring |
| 1 | 934006 | O-Ring |
| 1 | 934007 | O-Ring |
| 1 | 934015 | O-Ring |
| 2 | 934029 | O-Ring |
| 1 | 943102 | O-Ring |
| 1 | 1900013 | O-Ring |

Button Head Coupler Repair Kit #47524*

Consists of 1 each: Spring, Washer, O-Ring, Valve

Check Valve Assembly #60059*

| Qty. | Part Number | Part Description |
|------|-------------|------------------|
| 1 | 60045 | Screw |
| 1 | 60046 | Washer |
| 1 | 60083 | Screen |
| 1 | 905151 | Spring |
| 1 | 930206 | Ball |

400-D Hoses by Length (1/4" NPT Male a 1/2-27 Female)

| Hose Length | Part Number | Hose Length | Part Number |
|-------------|-------------|-------------|-------------|
| 1 ft. | 60076 | 3 ft. | 1900109 |
| 1.5 ft. | 47501 | 4 ft. | 47503 |
| 2 ft. | 47502 | 6 ft. | 47504 |

Linkage Assembly #60058

| Qty. | Part Number | Part Description |
|------|-------------|------------------|
| 2 | 60039 | Link |
| 3 | 1619604 | Washer |
| 3 | 908683 | Shoulder Screw |
| 3 | 1618357 | Lock Nut |
| 1 | 1900065 | Stop Link |

Floating Piston Assembly #1900009

| Qty. | Part Number | Part Description |
|------|-------------|------------------|
| 1 | 1900010 | Sealant Side Nut |
| 2 | 1900011 | Nylon Cup* |
| 1 | 1900012 | Body |
| 1 | 1900013 | O-Ring |
| 1 | 1900014 | Oil Side Nut |

Body Assembly #60065

| Qty. | Part Number | Part Description |
|------|-------------|------------------------------|
| 1 | 60040 | Hydraulic Pump Cylinder* |
| 1 | 60045 | Screw |
| 1 | 60046 | Washer |
| 1 | 60047 | By-Pass Stop Valve |
| 1 | 60048 | By-Pass Valve* |
| 1 | 60051 | Body |
| 1 | 60083 | Screen |
| 1 | 905151 | Spring |
| 2 | 908685 | By-Pass Stop Screw |
| 1 | 930206 | Ball |
| 1 | 934003 | Internal Relief Valve O-Ring |
| 1 | 934007 | By-Pass Valve O-Ring |
| 1 | 934015 | Pump Cylinder Top O-Ring |
| 1 | 934029 | O-Ring |
| 1 | 943102 | Pump Cylinder Bottom O-Ring |

Repair Tools

| Part Number | Part Description |
|-------------|------------------------------------|
| 47517 | Piston Pulling Tool |
| 47518 | Spanner Wrench for Pump Cylinder |
| 47519 | Spanner Wrench for Floating Piston |
| 47520 | Floating Piston Guide |
| 47521 | Gun Assembly Wrench |

*Component of Major Repair Kit

NORDSTROM 400-D Hand Gun Parts

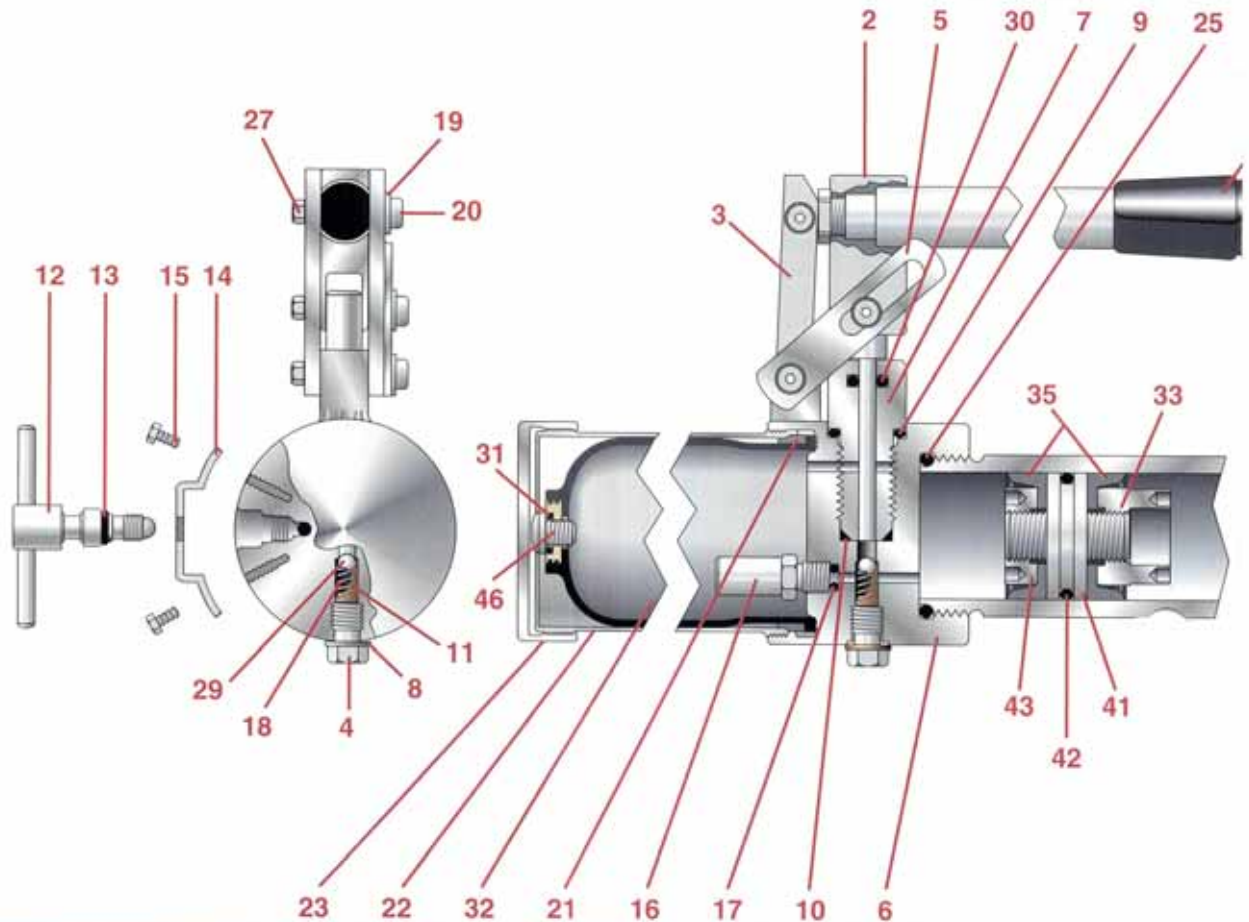

| Ref. | Part Name | Part Number | Qty. Reqd. |
|------|--|-------------|------------|
| 1 | Handle with Grip | 60033 | 1 |
| 2 | Fulcrum | 60036 | 1 |
| 3 | Link (2) | 60039 | 2 |
| 4 | Screw, Check Valve (4)(6) | 60045 | 1 |
| 5 | Stop Link (2) | 1900065 | 1 |
| 6 | Body, Hand Gun (4) | 60051 | 1 |
| 7 | Hydraulic Pump Cylinder with Piston (1)(4) | 60040 | 1 |
| 8 | Washer, Check Valve (4)(6) | 60046 | 1 |
| 9 | O-Ring, Pump Cylinder (top) (2)(4) | 934015 | 1 |
| 10 | O-Ring, Pump Cylinder (bottom) (2)(4) | 943102 | 1 |
| 11 | Screen, Check Valve (4)(6) | 60083 | 1 |
| 12 | By-Pass Valve (1)(4) | 60048 | 1 |
| 13 | O-Ring, By-Pass Valve (2)(4) | 934007 | 1 |
| 14 | By-Pass Stop (4) | 60047 | 1 |
| 15 | By-Pass Stop Screw (4) | 908685 | 2 |
| 16 | Internal Relief Valve (4) | 1900149 | 1 |

| Ref. | Part Name | Part Number | Qty. Reqd. |
|------|----------------------------------|-------------|------------|
| 17 | O-Ring, Relief Valve (2)(4) | 934003 | 1 |
| 18 | Spring, Check Valve (4)(6) | 905151 | 1 |
| 19 | Washer, Linkage (3) | 1619604 | 3 |
| 20 | Shoulder Screw, Linkage (3) | 908683 | 3 |
| 21 | Sealing Ring | 60060 | 1 |
| 22 | Fluid Bag Barrel | 60054 | 1 |
| 23 | Fluid Bag Barrel Cap | 60055 | 1 |
| 24 | Sealant Barrel | 60028 | 1 |
| 25 | O-Ring, Sealant Barrel (2)(4) | 934029 | 1 |
| 26 | Sealant Barrel Cap | 60026 | 1 |
| 27 | Lock Nut (3) | 1618357 | 3 |
| 29 | Ball, Check Valve (4)(6) | 930206 | 1 |
| 30 | O-Ring, Pump Cylinder Piston (2) | 934005 | 1 |
| 31 | O-Ring, Fluid Bag Screw (2) | 934006 | 1 |
| 32 | Fluid Bag (1) | 70960M | 1 |
| 33 | Nut, Sealant Side (5) | 1900010 | 1 |

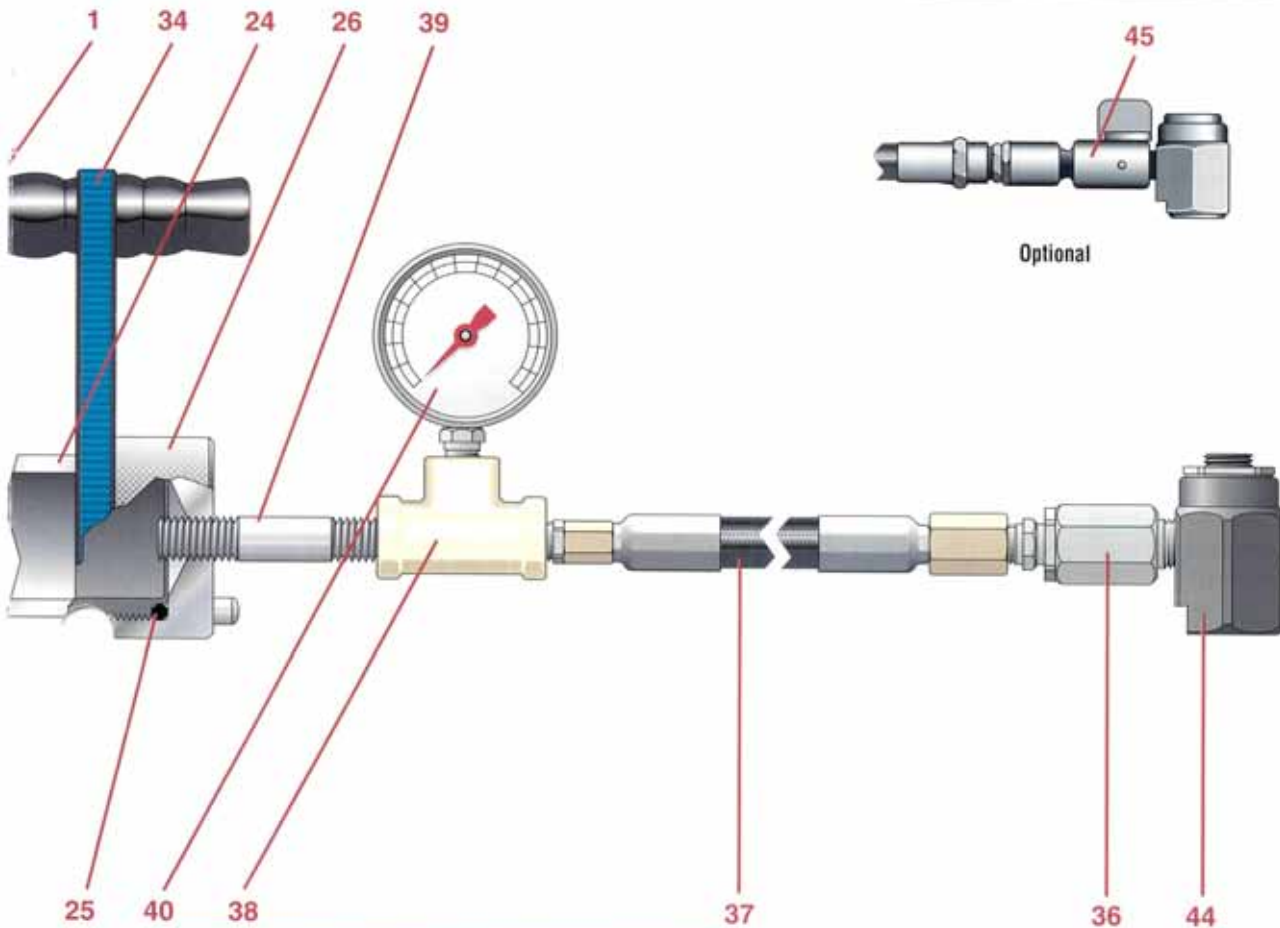

| Ref. | Part Name | Part Number | Qty. Reqd. |
|------|---|-------------|------------|
| 34 | Carry Strap | 60070 | 1 |
| 35 | Nylon Cup ⁽¹⁾⁽⁵⁾ | 1900011 | 2 |
| 36 | Straight Swivel | 927437 | 1 |
| 37 | One Foot Hose | 60075 | 1 |
| 38 | Tee | 1900074 | 1 |
| 39 | Nipple | 1900073 | 1 |
| 40 | 15,000 psi Gauge | 1900052 | 1 |
| 41 | Body, Floating Piston ⁽⁵⁾ | 1900012 | 1 |
| 42 | O-Ring, Floating Piston ⁽²⁾⁽⁵⁾ | 1900013 | 1 |
| 43 | Nut, Oil Side ⁽⁵⁾ | 1900014 | 1 |
| 44 | Giant Button Head Coupler | 64584 | 1 |
| 45 | Shutoff & Relief Valve (optional) | 60010 | 1 |
| 46 | Screw | 908705 | 1 |
| | Gauge Cover | 60090 | 1 |
| | Hydraulic Fluid (1 pint can) ⁽¹⁾ | 71251 | |
| | Z-Type Swivel (optional equipment) | 927436 | |

- (1) Component of Major Repair Kit
- (2) Component of Minor Repair Kit
- (3) Component of Linkage Assembly
- (4) Component of Body Assembly
- (5) Component of Floating Piston Assembly
- (6) Component of Check Valve Assembly

Care and Maintenance

Suggested 400-D Hand Gun Care

The following suggestions will ensure efficient and continued operation of the 400-D Hand Gun.

1. Do not carry the gun by the Handle unless secured with the Carry Strap. Carrying the gun with an unsecured handle can damage the Piston.
2. Keep the Piston area of the gun free of debris.
3. Do not unscrew the By-Pass Valve more than one complete turn. Doing so may allow air to enter the hydraulic system of the gun.
4. Protect the Gauge from damage.

400-D Hand Gun Maintenance

If the operating instructions are carefully followed and hydraulic fluid is added at regular intervals, the 400-D Hand gun will operate indefinitely without further maintenance. It is recommended a maintenance program be established where the number of hours the gun is used determines when maintenance is required.

Numbers in parentheses refer to parts as illustrated on pages 6 and 7 of this brochure.

Recharging and Bleeding the Hydraulic System of Air

1. Open the By-Pass Valve (12) and remove the Handle (1).
2. Remove the Sealant Barrel Cap (26) and stand the gun with the Sealant Barrel (24) up.
3. With the Handle, press the Floating Piston (41) to the bottom of the Sealant Barrel. Make sure the Floating Piston bottoms out in the Sealant Barrel.
4. Leave the Handle inside the Sealant Barrel and turn the gun so the sealant barrel is pointing downward and remove the Fluid Bag Barrel Cap (23).
5. Slowly remove the Screw (46) and O-Ring (31) from the Fluid Bag (32).
6. Allow the weight of the gun to rest against the Handle and slowly fill the Fluid Bag with Nordstrom Hydraulic Fluid. Allow the gun to stand 15 minutes to permit the air suspended in the fluid to escape. (It is recommended to allow the gun to sit for 2-3 hours after recharging the hydraulic system with fluid to allow the Fluid Bag to regain its original shape.)
7. Replace the Screw and O-Ring being careful not to entrap air.
8. Remove the Handle and replace the Fluid Bag Barrel Cap.
9. Reload the Gun with Sealant and replace the Sealant Barrel Cap.

Replacing the Hydraulic Fluid Bag

1. Remove the Handle (1), open the By-Pass Valve (12) and push the Floating Piston (41) to the bottom of the Sealant Barrel (24). Clean the Handle and replace.
2. Place the Fluid Bag Barrel (22) end of the gun in a vise.
3. Place a suitable size container below the vise to catch hydraulic fluid.
4. Using Gun Assembly Wrench 47521, remove the Body (6) and attached parts from the Fluid Bag Barrel. Hydraulic fluid will spill from the Fluid Bag.
5. If the Floating Piston (41) was not able to be returned to the bottom of the Sealant Barrel, return it now (see step 1).
6. Remove the damaged Fluid Bag (32) from the Fluid Bag Barrel and clean the barrel.
7. Remove the Sealing Ring (21).
8. Place the Sealing Ring onto the new Fluid Bag, loosen Fluid Bag Screw (46) and tighten snug.
9. Place the Fluid Bag into the Fluid Bag Barrel.
10. Fill the Fluid Bag to within 3/4" of the top with Nordstrom hydraulic fluid.

CAUTION: Take care to keep foreign matter from entering the hydraulic fluid. Debris in the hydraulic system can prevent the gun from operating properly.

11. Replace the gun assembly removed in Step 4 and tighten by hand.
12. Tighten the assembly to approximately 50 ft.-lbs. using the Gun Assembly Wrench.

CAUTION: Over tightening the Fluid Bag Barrel to the Body may damage the Fluid Bag Assembly.

13. After equipping the gun with a new Fluid Bag, recharge the gun with hydraulic fluid as described in this brochure.

Sealant Barrel Replacement

1. Open the By-Pass Valve (12) and push the Floating Piston (41) to the bottom of the Sealant Barrel (24).
2. Close the By-Pass Valve.
3. Place the Sealant Barrel end of the gun in a vise and, with Gun Assembly Wrench 47521, remove the Body (6) and attached parts from the Sealant Barrel.
4. Remove the Sealant Barrel from the vise and push the Floating Piston from the Sealant Barrel. Note the position of the assembly when removing.

- Using Floating Piston Guide 47520, place the Floating Piston into the non-knurled end of the new Sealant Barrel. The Floating Piston should be flush with the bottom of the Sealant Barrel.

CAUTION: Make sure the Sealant Barrel and Floating Piston Assembly are free of contaminants prior to assembly.

- Replace the Sealant Barrel O-Ring (25).
- Place the Sealant Barrel onto the Body, with the knurled end furthest away from the Body, and tighten hand-tight.
- Place the Sealant Barrel end of the gun into the vise and tighten the Body using Gun Assembly Wrench.
- After equipping the gun with a new Sealant Barrel, recharge the gun with hydraulic fluid as described in this brochure.

Pump Cylinder Replacement

- Remove the Handle (1), open the By-Pass Valve (12) and push the Floating Piston (41) to the bottom of the Sealant Barrel (24). Clean the Handle and replace.
- With the gun in the horizontal position, Handle (1) up, remove the Shoulder Screw (20) from the Pump Piston.
- Tip the linkage back.
- Unscrew the Hydraulic Pump Cylinder (7) with Spanner Wrench 47518. (The cylinder cavity will probably fill with hydraulic fluid - do not disturb this condition.)
- Replace the O-Ring (10) in the bottom of the cylinder cavity of the Body.
- Install O-Ring (9) on the new Hydraulic Pump Cylinder. It is recommended that the cylinder be replaced as assembly 60040.
- Install the new Hydraulic Pump Cylinder into the Body (6) and tighten with Spanner Wrench 47518.
- Reconnect the Linkage.
- After equipping the gun with a new Hydraulic Pump Cylinder, recharge the gun with hydraulic fluid as described in this brochure.

Pump Cylinder Piston O-Ring Replacement

Remove the defective Pump Cylinder Piston O-Ring (30) using a sharp object. Pinch the O-Ring between the forefinger and thumb. Push the O-Ring into the top of the Pump Cylinder so that it partially enters the O-Ring groove. Use a blunt instrument to work the O-Ring completely into the groove.

Check Valve Repair

Symptoms of Check Valve failure are easily recognizable. When the Handle develops a spring-like action where, under pressure, the Handle will spring back each time it is pushed down, the Check Valve is not seating properly. This is usually indicative of a foreign particle on the valve seat.

- Open the By-Pass Valve (12) and push the Floating Piston (41) to the bottom of the Sealant Barrel (24).
- Close the By-Pass Valve.
- Place the gun in a vise on a workbench and loosen the Check Valve Screw (4).
- Remove the Check Valve Screw and Washer (8) and turn the gun Check Valve down so the Spring (18) Ball (29), and Filter (11) fall out.
- Using a pointed instrument, remove the cylindrical Screen (11) from the Check Valve cavity.
- Thoroughly clean the Check Valve seat and cavity with a lint-free paper towel. The cleaning must be thorough or the Check Valve may not seat.
- Position the gun on the workbench with the Check Valve cavity up.
- Insert the Ball.
- With the Ball in position on the seat, place a short length of 1/4" brass or cold rolled rod on the Ball and, with a firm blow from a hammer, seat the Ball.
- Turn the Body over and remove the Ball by tapping the unit against your hand.
- Clean the cavity and seat the Ball again.
- Turn the Body upside down. If the Ball falls out, repeat the seating procedure until the Ball does not fall out without assistance.
- Insert the Screen and Spring.
- Replace the Washer and Check Valve Screw and tighten the screw snugly being careful to not over tighten.
- After equipping the gun with a new Check Valve Assembly, recharge the gun with hydraulic fluid as described in this brochure.

By-Pass Valve Replacement

- Remove the Handle (1), open the By-Pass Valve (12) and push the Floating Piston (41) to the bottom of the Sealant Barrel (24). Clean the Handle and replace.
- Remove the By-Pass Stop Screw (15) and the By-Pass Valve Stop (14).
- Remove the damaged By-Pass Valve.
- Lubricate the By-Pass Valve O-Ring (13) on the new By-Pass Valve.

Care and Maintenance (cont.)

- To avoid damage to the O-Ring, carefully screw the By-Pass Valve into the Body until the O-Ring engages the Body. Screw the valve in 1/2 turn, and unscrew 1/4 turn. Repeat this procedure until the O-Ring has entered the Body and the By-Pass Valve has seated.

CAUTION: If hydraulic fluid is present in the By-Pass Valve cavity of the Body, fluid back pressure may shear the O-Ring and the O-Ring must be replaced.

- After installing a new By-Pass Valve, recharge the gun with hydraulic fluid as described in this brochure.

Floating Piston Replacement

- Remove the Sealant Barrel Cap (26) and open the By-Pass Valve (12).
- Push Piston Assembly to bottom of Sealant Barrel (24) with Handle (1). Clean the Handle and replace.
- Remove the Sealant Barrel from the gun (see instructions listed in Sealant Barrel Replacement).
- Remove the Floating Piston (41) from the Sealant Barrel using Piston Pulling Tool 47517.
- Place the Floating Piston into a vise and disassemble using Spanner Wrench 47518.
- Replace the O-Ring (42) and Nylon Cups (35).
- Tighten the assembly using two spanner wrenches.
- Replace the Floating Piston using Piston Guide Tool 47520. The assembly should be positioned flush with the bottom of the Sealant Barrel.
- After installing the Floating Piston, recharge the gun with hydraulic fluid as described on page 8 of this brochure.

Sealant Change-out

- Remove the Sealant Barrel Cap (26) complete with hose assembly.
- Force Piston Pulling Tool 47517 into the center of the sealant in the Sealant Barrel (24) and push until the tool is in contact with the Floating Piston (41).
- Screw the tool into the Floating Piston, open the By-Pass Valve (12), and pull the piston out of the barrel until the assembly is flush with the end of the barrel.
- Remove the Piston Pulling Tool and scrape the existing sealant from the end of the Floating Piston.
- Follow instructions for Loading the 400-D Hand Gun with Sealant as listed in this brochure.
- Attach a sealant fitting to the Giant Button Head Coupler (44) and purge old sealant from the hose by operating the gun until new sealant is pumped through the fitting.

Factory Repair Service

Factory Repair Service is available from Nordstrom Valves, Inc. Consult your Authorized Distributor or Nordstrom Customer Service for more details.

Troubleshooting Guide

These troubleshooting tips are provided as a means of assisting the consumer in recognizing operational difficulties sometimes associated with the 400-D Hand Gun. Part numbers in parentheses denote illustration numbers as listed on pages 6 & 7 of this brochure.

WARNING: Never attempt to repair a 400-D Hand Gun without relieving the hydraulic pressure.

■ **Problem:** The gun will not pump.

Cause 1: Air has entered the hydraulic system.

Solution 1: Bleed the hydraulic system. See page 8 of this brochure. *Tip!: With the Fluid Bag end of the Gun positioned vertically in a vice, the Fluid Bag full of oil, the Floating Piston pushed all the way into the Sealant Barrel, and the By-Pass Valve open two full turns, pump the handle 10-15 times. This will ensure air entrapped in the hydraulic system passages has been pumped into the Fluid Bag and allowed to escape to the atmosphere.*

Cause 2: The Piston is broken.

Solution 2: Replace the Pump Cylinder/Piston assembly. See page 9 of this brochure.

Cause 3: The gun is void of sealant.

Solution 3: Refill the gun with sealant. See page 4 of this brochure.

Cause 4: A Gun Pak bag has been forced into the hose by attempting to inject sealant after the gun is void of sealant.

Solution 4: Remove the Hose Assembly from the gun and remove the bag from the Hose. You may attempt this by flipping the hose and pumping out the bag. Replace the Hose if the bag cannot be removed.

Cause 5: The Giant Button Head Coupler is damaged.

Solution 5: Replace the Giant Button Head Coupler or repair the coupler using repair kit 47524.

Cause 6: Ambient temperature is low enough to cause the sealant to become more viscous.

Solution 6: Place the gun and sealant in a warm place and only expose then to the cold temperature only during valve injection.

■ **Problem:** The gun is difficult to pump.

Cause 1: The supply of sealant is depleted.

Solution 1: Reload the gun with sealant. See page 4 of this brochure.

Cause 2: The injection pressure of the sealant has not lifted the plug from the seat of the valve.

Solution 2: Continue to inject sealant until the plug has been lifted from the seat of the valve or until the Internal Relief Valve relieves.

■ **Problem:** Hydraulic fluid leakage around the Body and Fluid Barrel threads.

Cause 1: Hydraulic Fluid is leaking past the Screw and O-Ring in the end of the Hydraulic Fluid Bag.

Solution 1: Carefully tighten the Screw.

Cause 2: The Hydraulic Fluid bag is damaged.

Solution 2: Replace the Hydraulic Fluid Bag. See page 8 of this brochure.

■ **Problem:** Floating Piston Assembly will not return to the bottom of the Sealant Barrel.

Cause 1: Air in hydraulic system.

Solution 1: Bleed the hydraulic system. See page 8 of this brochure. See tip for problem "The gun will not pump".

Cause 2: Excessive hydraulic fluid in gun.

Solution 2: Remove the Sealant Barrel Cap and insert the Handle into sealant barrel against the Floating Piston. Turn gun upside down and let the weight of the gun rest on the Handle. Remove the hydraulic Fluid Barrel Cap. Slowly remove the Screw and O-Ring, located in the end of the Hydraulic Fluid Bag, while lightly pressing the gun down against the Handle. This will force out excessive hydraulic fluid. This procedure should be performed over a basin to catch the excess hydraulic fluid. Once the Piston is all the way to the bottom of the Sealant Barrel, insert the Screw and O-Ring into the Fluid Bag and replace the Fluid Barrel Cap.

■ **Problem:** Hydraulic fluid leakage at the Sealant Barrel to Body threads.

Cause 1: The hydraulic fluid side Nylon Cup or O-Ring has been damaged allowing hydraulic fluid to enter the sealant side of the Hydraulic Piston.

Solution 1: Clean and check the Nylon Cups for damage. Replace parts if required. See page 10 of this brochure.

Cause 2: The cylinder wall of the Sealant Barrel has been scored allowing hydraulic fluid to enter the sealant side of the Hydraulic Piston.

Solution 2: Clean and check the Sealant Barrel for damage. Replace the part if required. See page 8 of this brochure.

■ **Problem:** The gun will not develop pressure when pumping.

Cause 1: Air is present in the hydraulic system.

Solution 1: Bleed the hydraulic system. See page 8 of this brochure.

Cause 2: The Check Valve Assembly is faulty.

Solution 2: Repair or replace the Check Valve Assembly. See page 9 of this brochure.

Cause 3: By-Pass Valve (12) is not sealing.

Solution 3: Tighten By-Pass Valve while lightly tapping with small hammer.

Cause 4: The Internal Relief Valve (16) has failed.

Solution 4: Replace the Internal Relief Valve.



Authorized Distributors

For detailed information on these and other Nordstrom products, call your customer service representative for the name and number of the nearest authorized Nordstrom distributor.

1511 Jefferson Street
Sulphur Springs, Texas 75482
USA

1-800-225-6989

Email: nmkt@flowserve.com
or visit www.flowserve.com

United States :
Telephone: 903-885-4691 or 4693
FAX: 903-439-3411
Latin America:
Telephone: 903-439-3407
Fax: 903-439-3411
Other Countries:
Telephone: 903-885-4692
Fax: 903-439-3404



Nordstrom Valves

Flowserve Corporation has established industry leadership in the design and manufacture of its products. When properly selected, this Flowserve product is designed to perform its intended function safely during its useful life. However, the purchaser or user of Flowserve products should be aware that Flowserve products might be used in numerous applications under a wide variety of industrial service conditions. Although Flowserve can (and often does) provide general guidelines, it cannot provide specific data and warnings for all possible applications. The purchaser/user must therefore assume the ultimate responsibility for the proper sizing and selection, installation, operation, and maintenance of Flowserve products. The purchaser/user should read and understand the Installation Operation Maintenance (IOM) instructions included with the product, and train its employees and contractors in the safe use of Flowserve products in connection with the specific application.

While the information and specifications contained in this literature are believed to be accurate, they are supplied for informative purposes only and should not be considered certified or as a guarantee of satisfactory results by reliance thereon. Nothing contained herein is to be construed as a warranty or guarantee, express or implied, regarding any matter with respect to this product. Because Flowserve is continually improving and upgrading its product design, the specifications, dimensions and information contained herein are subject to change without notice. Should any question arise concerning these provisions, the purchaser/user should contact Flowserve Corporation at any one of its worldwide operations or offices.

For more information about Flowserve Corporation, contact www.flowserve.com or call USA 1.800.225.6989.