



ROMAC DUCTILE LUG

RESTRAINT SYSTEMS

MATERIAL SPECIFICATIONS

LUG: Ductile iron per ASTM A 536, Grade 65-45-12.

USE: Restraint of MJ fittings 4" - 24". Accommodates 3/4" rod.

MAX. LOAD: 7,500 lbs.

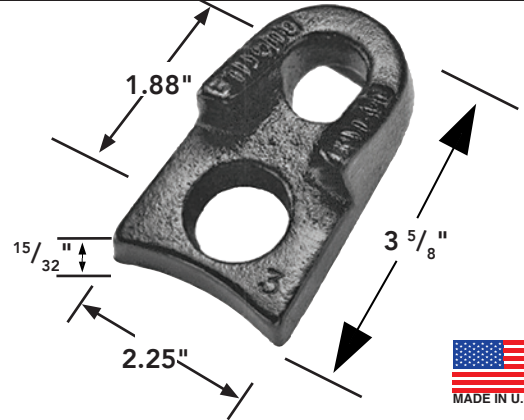
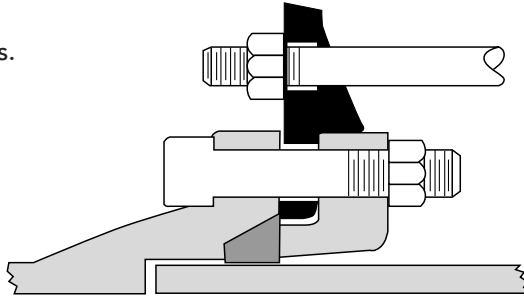

CATALOG NUMBER	APPROX. WEIGHT (lbs.)	LIST PRICE
Ductile Lug	.844 #	\$4.50

90° EYE BOLT

MATERIAL SPECIFICATIONS

EYE BOLT: 3/4" UNC rolled thread, high strength, low alloy steel per AWWA C111 (Corten or Mayari-R).

NUT AND WASHER: 3/4" heavy hex, high strength low alloy steel.

USE: Restraint of MJ fittings 4" - 24". Accommodates 3/4" rod.

MAX. LOAD: 7,500 lbs.

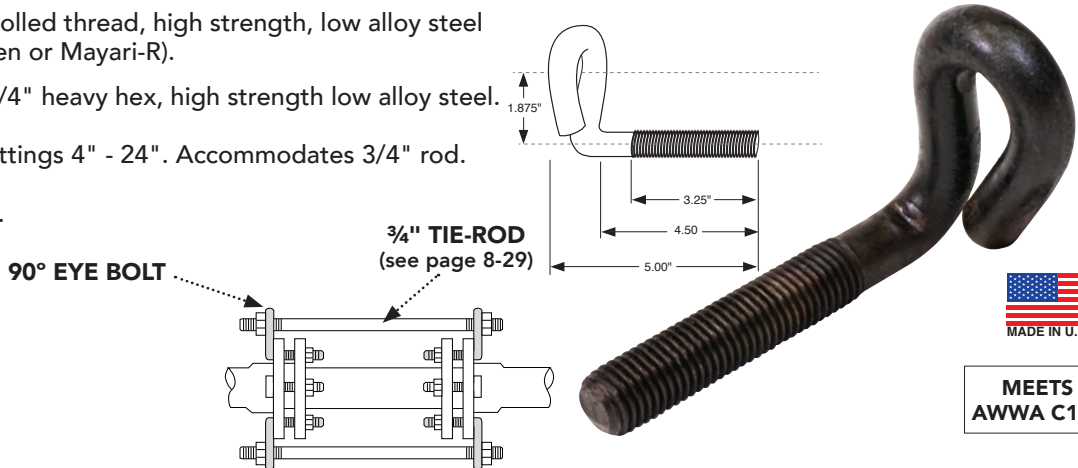

MEETS AWWA C111

ITEM	CATALOG NUMBER	LIST PRICE EACH PER QUANTITY					APPROX. WEIGHT (lbs.)
		1-200	400	600	800	1000	
3/4" Eye-Bolts	EYE-3/4	\$11.84	\$11.76	\$11.68	\$11.57	\$11.42	1.08 # / ea.
3/4" Nuts	HH-3/4	1.87	1.80	1.74	1.66	1.58	.70 # / ea.
3/4" Washers	WASHER-3/4	1.66	1.55	1.55	1.48	1.38	.20 # / ea.

TO ORDER: Specify catalog number.