

**No. 1-RT - RISER RING - 1 1/4"**

WT. 15 lbs.

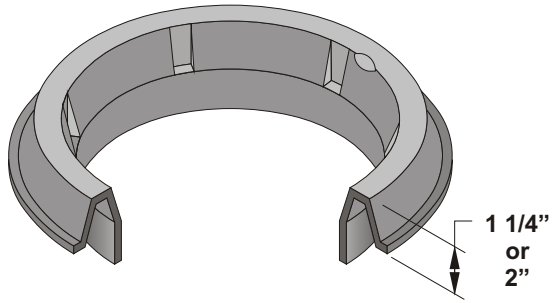

**No. 1-RT - EXTENSION - 6"**

WT. 10 lbs.

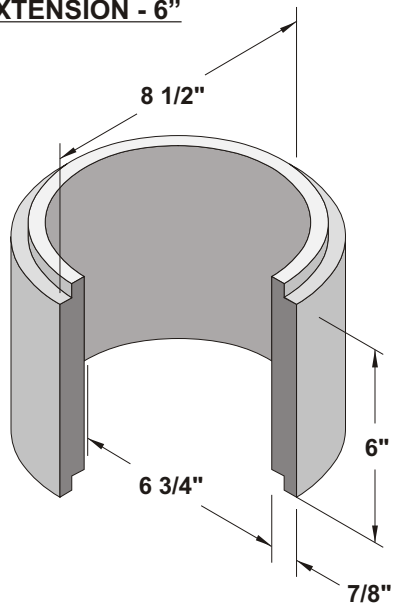

**No. 1-RT - EXTENSION - 12"**

WT. 19 lbs.

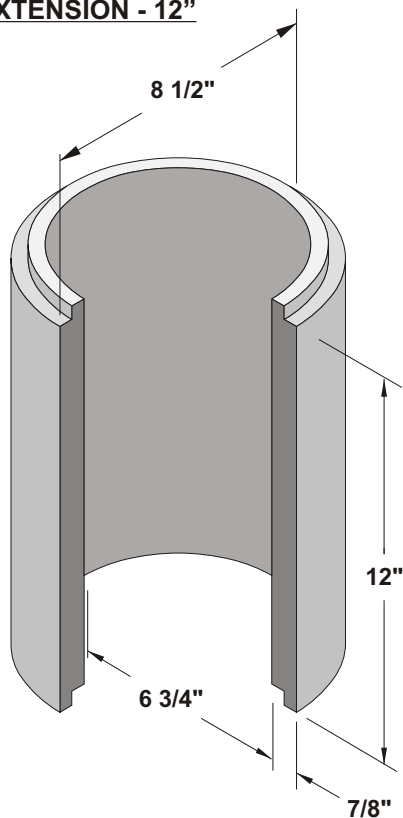

**No. 1-RT-CI COVER**

WT. 12 lbs.

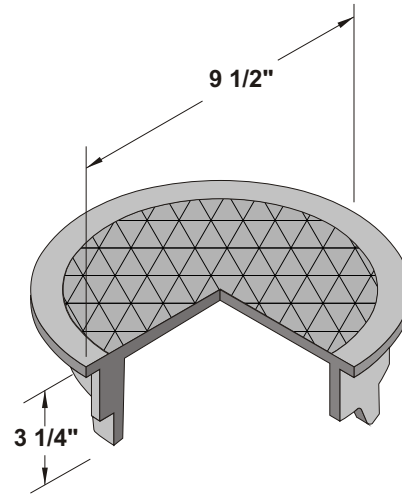

**No. 1-RT - BODY**

WT. 54 lbs.

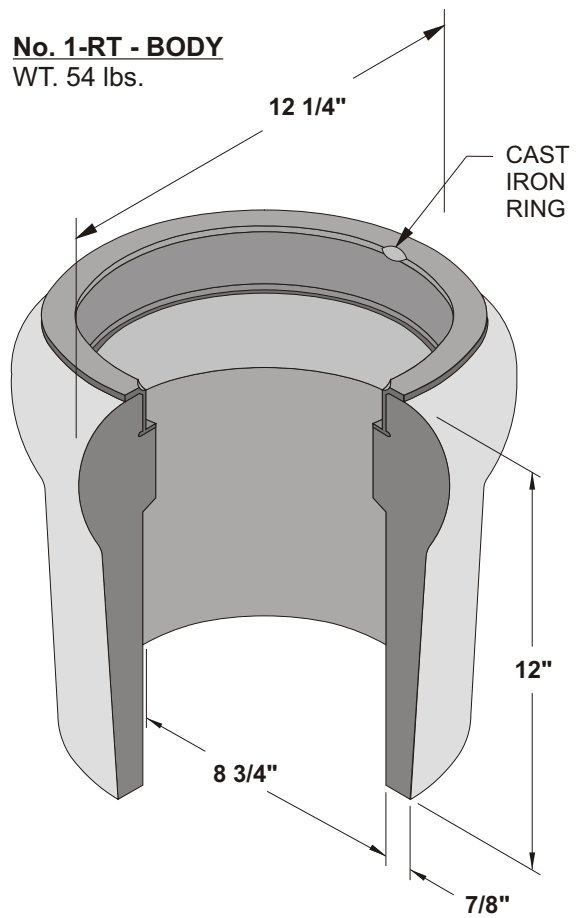

8 3/4" Dia. x 12"  
TRAFFIC VALVE BOX



1-RT

ORG. DWG. DATE  
01-11-96

REV. DWG. DATE  
11-13-00