

No. 3-RT - RISER RING - 1 1/4"

WT. 15 lbs.

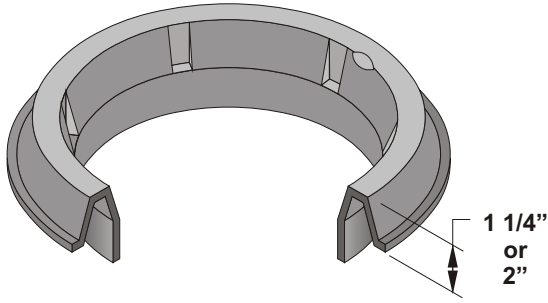

No. 3-RT - EXTENSION - 6"

WT. 13 lbs.

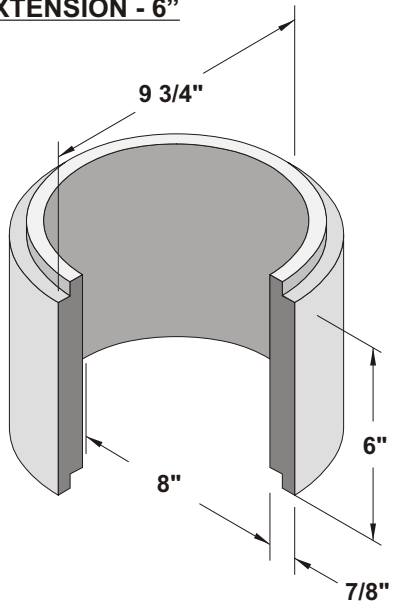

No. 3-RT - EXTENSION - 12"

WT. 23 lbs.

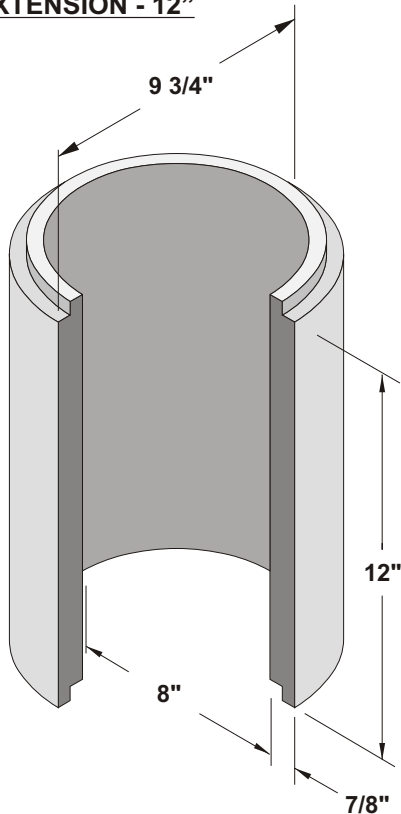

No. 3-RT-CI COVER

WT. 12 lbs.

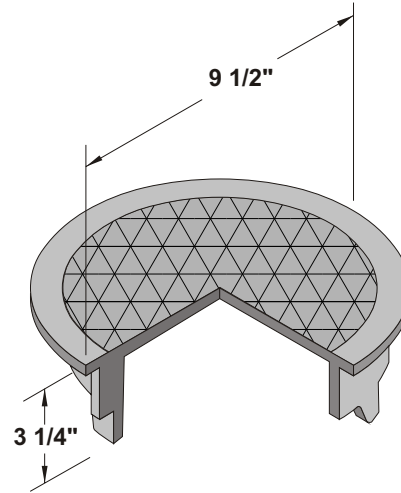

No. 3-RT - BODY

WT. 54 lbs.

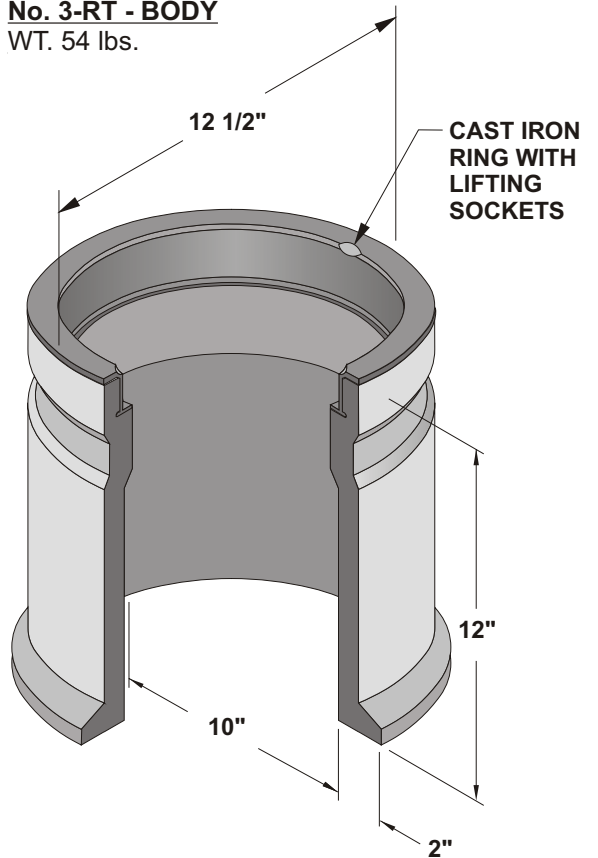

10" Dia. x 12"
TRAFFIC VALVE BOX

ORG. DWG. DATE
01-11-96

REV. DWG. DATE
08-17-00



3-RT