

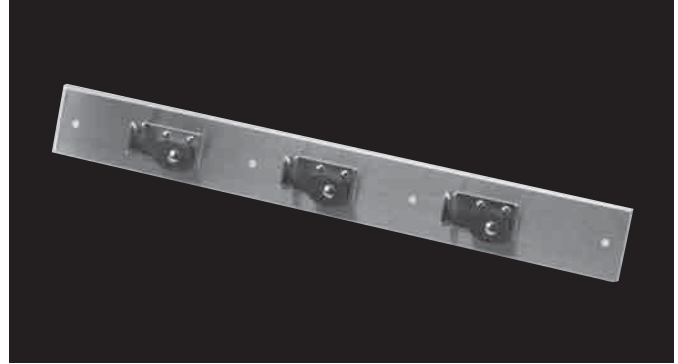

# Hose Bracket

## Product Specifications

- Mop hanger for service sink



## Product Numbers

- PF245 Three bracket hanger
- PF296 Single hose bracket, for use with service sink hose PFSSHE

PF245

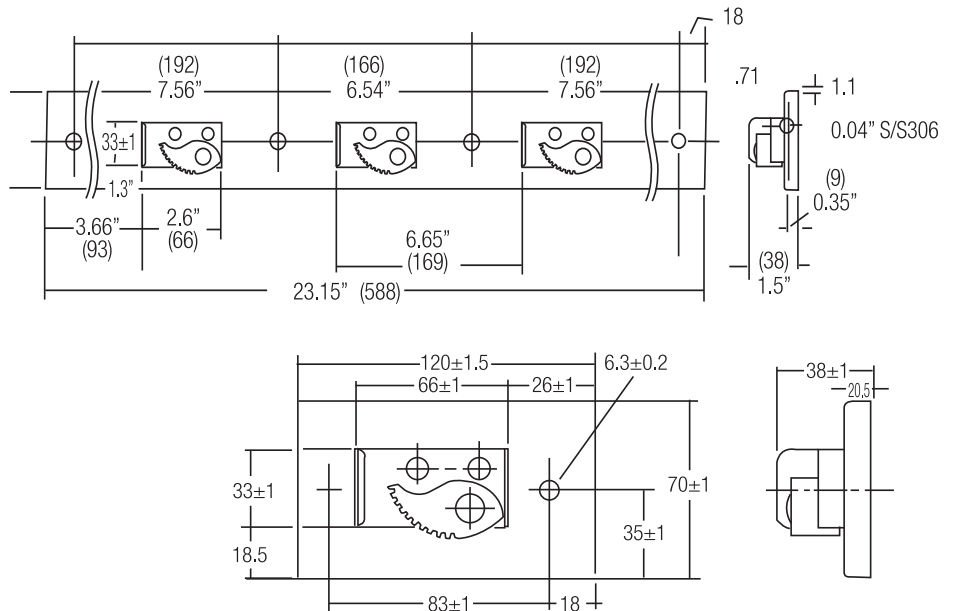

## Optional Accessory

- PFSSHE



I.D.	O.D.	Max Water Pressure	Weight per Foot
5/8" (16 mm)	29/32" (23mm)	300 PSI	.22

## Warranty and Codes

PROFLO toilet seats carry a 1-year limited warranty. In an effort to continually improve our products, We will make design changes from time to time. We reserve the right to ship newly designed product to fill any order unless we agree in writing to do otherwise.