

NOTES:

1. IN ORDER TO COMPLY WITH STATE CODES, THE USE OF A VACUUM BREAKER IS REQUIRED WITH ALL HAND HELD EYE/FACE WASH AND BODY SPRAY UNITS (HAWS OFFERS MODEL SP212).

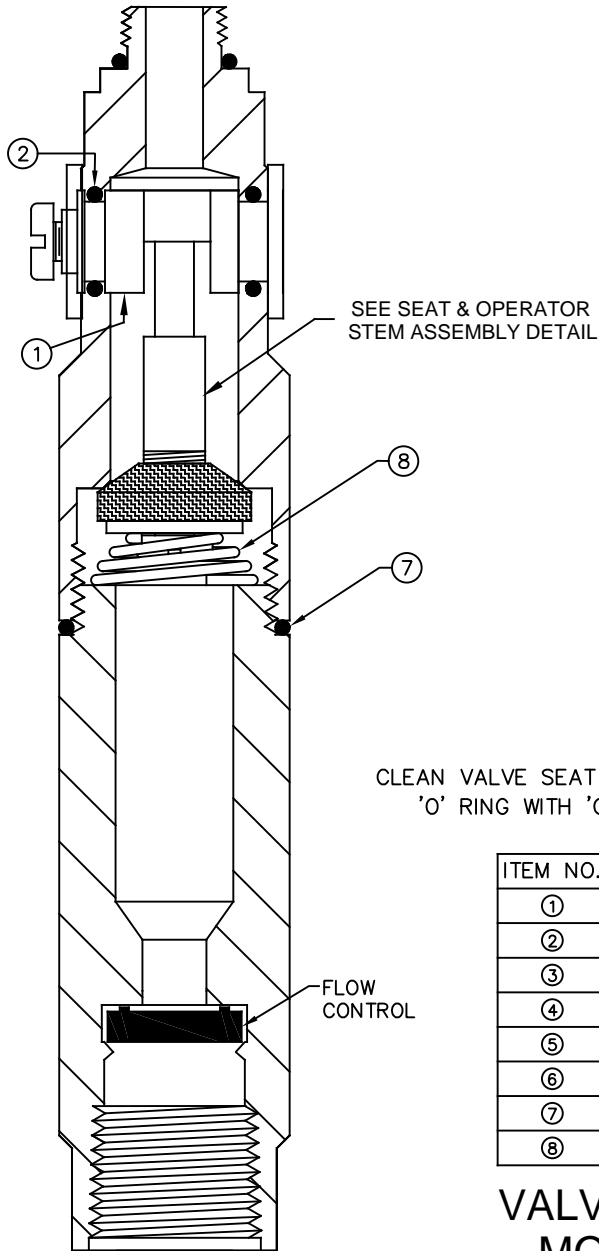

SEE SEAT & OPERATOR STEM ASSEMBLY DETAIL

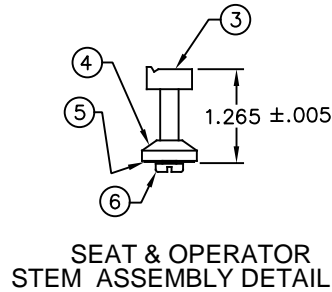

CLEAN VALVE SEAT AND WASHER THOROUGHLY, LUBRICATE 'O' RING WITH 'O' RING LUBE BEFORE REASSEMBLING.

ITEM NO.	QUANTITY	DESCRIPTION
①	1	CAM OPERATOR
②	2	'O' RING FOR CAM
③	1	OPERATOR STEM
④	1	SEAT WASHER
⑤	1	HOLDER WASHER
⑥	1	SCREW
⑦	1	'O' RING
⑧	1	SPRING

VALVE REPAIR DETAIL  
MODEL VRK SP248  
OPTIONAL

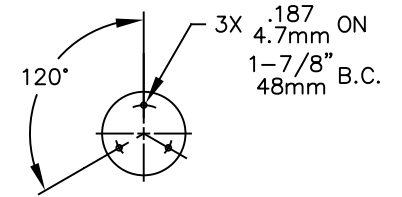

WALL BRACKET DETAIL

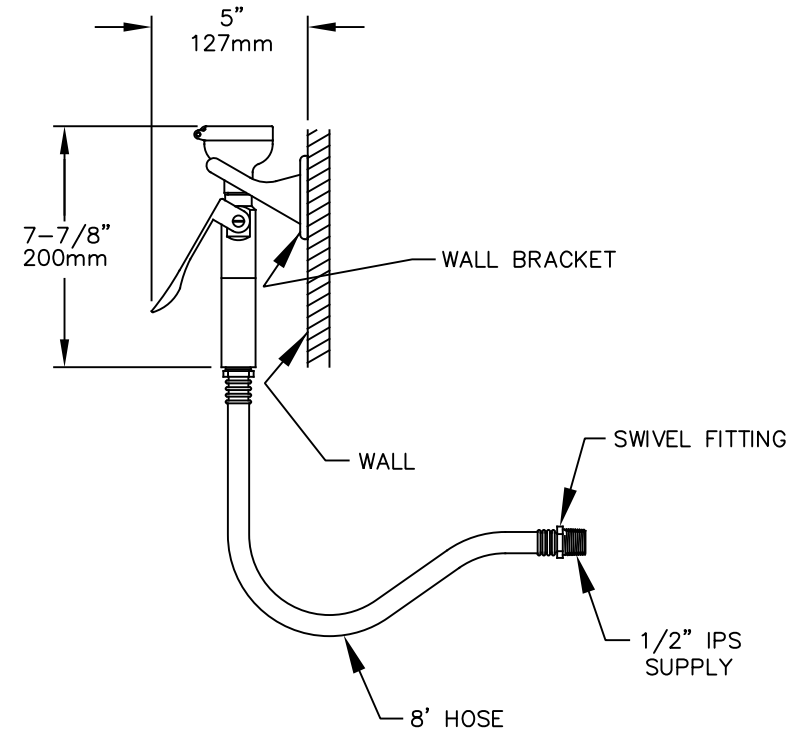



**Haws**

1455 KLEPPE LANE  
SPARKS, NEVADA 89431  
(775) 359-4712 FAX (775) 359-7424  
E-MAIL: HAWS@HAWS.CO.COM  
WEBSITE: WWW.HAWS.CO.COM

ECN NO.	REVISED PER	BY:	MODEL(S)	PART NUMBER
CH	DATE: 05/20/91	VWC	8901B	0002080191.D
DRAWN:	DATE:	CHKD.:	EYE/FACE WASH BODY SPRAY	REVISION
CH	05/20/91	VWC		9
APPROVED:	DATE:	SCALE:	DRAWING TYPE:	INSTALLATION
FV	11/23/17	NA		SIZE: A SHEET 1 OF 1