

# DIMENSIONS AND WEIGHTS

## SUBMITTAL AND DATA SHEET

### PERFORATED UNDERDRAIN PIPE ::

#### JM EAGLE™ PVC ASTM D3034 SOLVENT WELD SDR35 SEWER PIPE

JM EAGLE™ SOLVENT WELD SEWER PIPE CONFORMS TO SPECIFICATIONS PRIOR TO PERFORATION AND CELL CLASS 12454 OR 12364 AS DEFINED IN ASTM D1784

NOM. PIPE SIZE (IN)	O.D. (IN)	NOM. I.D. (IN)	MIN T. (IN)	APPROX. WEIGHT (LBS/FT)
4"	4.215	3.961	0.120	1.022
4" x 10' Perf	4.215	3.961	0.120	1.022
6"	6.275	5.893	0.180	2.285
6" x 10' Perf	6.275	5.893	0.180	2.285

:: Standard Color: Green, Standard length: 10' or 20' Overall, Belled End Only.

:: Standard perforations for pipe are two rows of holes ½" in diameter on 5" centers and 120° angle apart. Perforated pipe does not have ASTM designation on print line.

**When using JM Eagle™ PVC ASTM D3034 Solvent Weld Sewer Pipe for septic tank fields, please install in accordance with ASTM D2321, and JM Eagle™ Publication JME-05B, "Gravity Sewer Installation Guide."**

#### JM EAGLE™ PVC ASTM D2729 SOLVENT WELD DRAIN PIPE

JM EAGLE™ SOLVENT WELD DRAIN PIPE CONFORMS TO SPECIFICATIONS AND CELL CLASS 12454 OR 12164 AS DEFINED IN ASTM D1784

NOM. PIPE SIZE (IN)	O.D. (IN)	NOM. I.D. (IN)	MIN T. (IN)	APPROX. WEIGHT (LBS/FT)
3" Solid	3.250	3.102	0.070	0.465
3" Perf	3.250	3.102	0.070	0.465
4" Solid	4.215	4.056	0.075	0.648
4" Perf	4.215	4.056	0.075	0.648
6" Solid	6.275	6.063	0.100	1.300
6" Perf	6.275	6.063	0.100	1.300

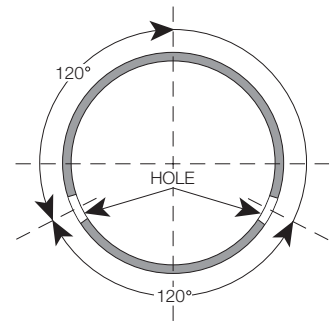

:: Standard Color: White, Standard length: 10' Overall, Belled End Only.

:: Standard perforations for pipe are two rows of holes ½" in diameter on 5" centers and 120° angle apart. Three perforation rows may be available.

**When using JM Eagle™ PVC ASTM D2729 Solvent Weld Drain Pipe for septic tank fields, please install in accordance with ASTM F481, and JM Eagle™ Publication JME-05B, "Gravity Sewer Installation Guide."**

\* Prior to ordering or specifying, please consult JM Eagle™ for product and /or listing availability.

I.D. : Inside Diameter

O.D. : Outside Diameter

T. : Wall Thickness