

GATE IB640 BRONZE

125 lb. SWP-200 lb. WOG† • General Service
Solid Wedge Disc • Rising Stem
Threaded Bonnet • Gland Packed • Threaded Ends

4" size has split wedge and bolted bonnet. It is not covered in MSS SP-80.

SPECIFICATIONS

IB640	Conforms to: MSS SP-80. Type 2, Class 125, Threaded Ends.
-------	--

MATERIAL LIST

NO.	PART	MATERIAL	SPECIFICATION
1	Body	Bronze	ASTM B 62
2	Bonnet	Bronze	ASTM B 62
3	Wedge	Bronze	ASTM B 62
4	Stem	Bronze	ASTM B 62
5	Stuff Nut	Brass	ASTM B 283 C37700
6 ¹	Gland	Brass	ASTM B 124 C37700
7	Wheel Nut	Brass	Commercial
8	Handwheel	Mall. Iron	Commercial
9	Packing	Non-Asbestos	
10	Name Plate	Sh. Alum.	Commercial

¹ Not used on 1/2" and smaller.

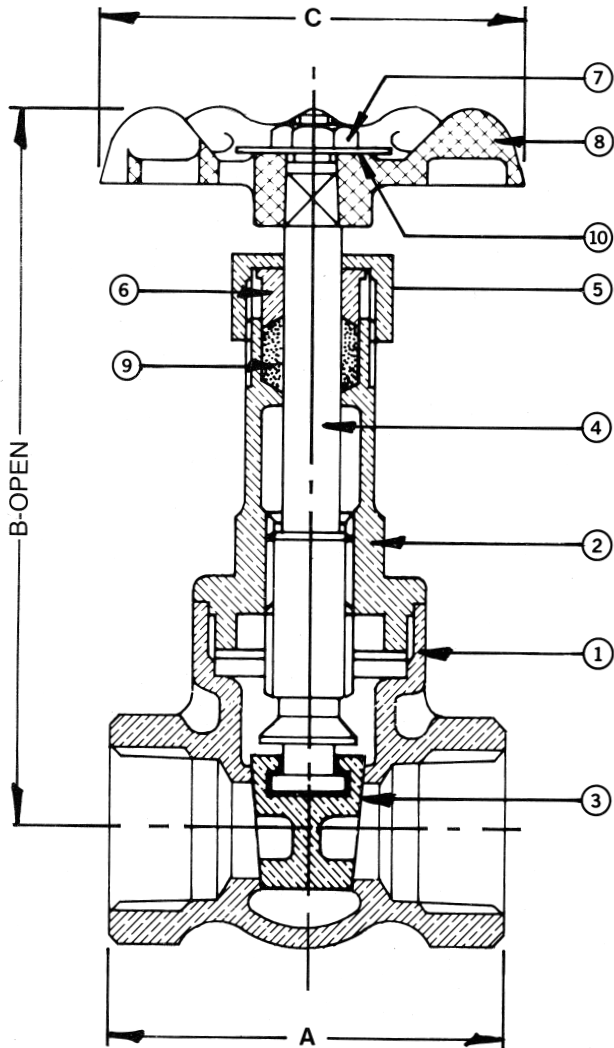

DIMENSIONS - INCHES / MILLIMETERS

Units	Size	A	B	C
Inches	1/4	1 3/4	4 3/8	2
MM	6.35	44.45	111.13	50.80
Inches	3/8	1 13/16	4 3/8	2
MM	9.53	46.05	111.13	50.80
Inches	1/2	2	4 3/8	2
MM	12.70	50.80	111.13	50.80
Inches	3/4	2 1/8	5 27/32	2 1/2
MM	19.05	53.98	148.44	63.50
Inches	1	2 9/16	7 1/16	2 3/4
MM	25.40	65.10	179.40	69.85
Inches	1 1/4	2 25/32	8 25/32	3 1/8
MM	31.75	70.64	223.04	79.38
Inches	1 1/2	2 13/16	9 1/2	3 1/2
MM	38.10	71.45	241.30	88.90
Inches	2	3 5/16	11 1/2	3 3/4
MM	50.80	84.15	292.10	95.25
Inches	2 1/2	4 3/16	14 5/16	4 3/4
MM	63.50	106.38	363.55	120.65
Inches	3	4 5/8	16 5/8	5 1/4
MM	76.20	117.48	422.28	133.35
Inches	4	5 1/2	15 1/2	5 1/4
MM	101.60	139.70	393.70	133.35

† Non-Shock

Rev. 1

BETTER AT EVERY TURN

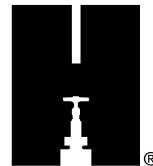

HAMMONDVALVE

www.hammondvalve.com

The information presented on this sheet is correct at the time of publication. Hammond Valve reserves the right to change design, and/or material specifications without notice. For the most current information access www.hammondvalve.com