

## 200 WOG SWING CHECK VALVE

**Features:**

- 200 WOG
- Temperature: -4°F to 356°F
- Investment Cast Components
- Stainless Steel Body and Trim
- Solid One-Piece Disc
- Threaded NPT Ends

**Standards:**

- Material: ASTM/ASME B16.34
- Connections: ANSI B1.20.1 (NPT)



**Cv & Weights**

Size	Cv	Wt. (lbs.)
1/4	3.2	1.2
3/8	6.7	1.1
1/2	9.0	1.0
3/4	16.6	1.7
1	27.0	2.1
1-1/4	45.0	3.2
1-1/2	72.4	4.4
2	118.9	6.0

**Figure Number Matrix**

FNW 16B 200 <u>Size</u>	
SIZE CODE	
1/4 = B	1 = G
3/8 = C	1-1/4 = H
1/2 = D	1-1/2 = J
3/4 = F	2 = K

## 200 WOG SWING CHECK VALVE

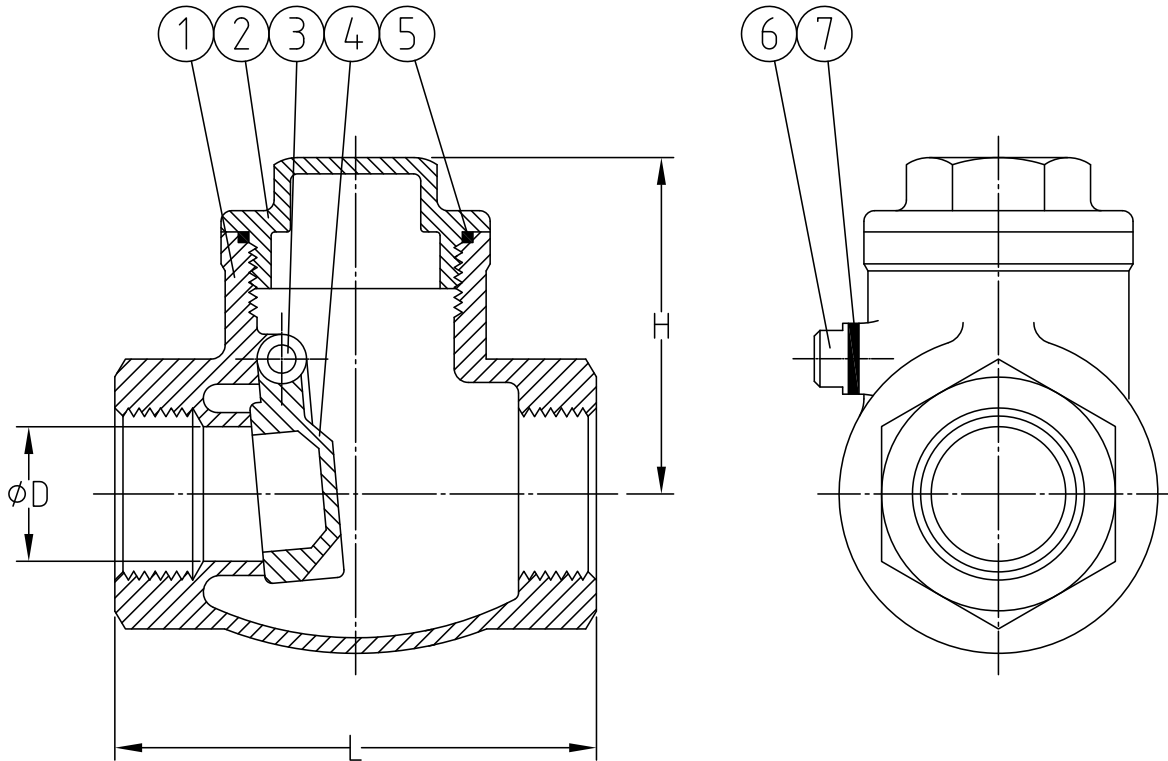

### Dimensions (inches)

Size	ØD	L	H
1/4	0.44	2.56	1.65
3/8	0.51	2.56	1.65
1/2	0.59	2.56	1.65
3/4	0.79	3.15	2.01
1	0.98	3.54	2.36
1-1/4	1.26	4.13	2.60
1-1/2	1.57	4.72	2.95
2	1.97	5.51	3.15

### Standard Materials

Ref. No.	Description	Material	Qty
1	Body	ASTM A351 Gr. CF8M	1
2	Cap	ASTM A351 Gr. CF8M	1
3	Hanger Pin	316SS	1
4	Disc	ASTM A351 Gr. CF8M	1
5	Body Seal	PTFE	1
6	Plug	316SS	1
7	Plug Gasket	PTFE	1

DOC: FNW16B06 Ver. 1/2012

© 2012 - FNW. All rights reserved.

The FNW logo is a trademark of Ferguson Enterprises, Inc., PL Sourcing, PO Box 2778, Newport News, VA 23609

The contents of this publication are presented for information purposes only, and while effort has been made to ensure their accuracy, they are not to be construed as warranties or guarantees, expressed or implied, regarding the products or services described herein or their use or applicability. All sales are governed by our terms and conditions, which are available on request. We reserve the right to modify or improve the designs or specifications of our products at any time without notice. Always verify that you have the most recent product specifications or other documentation prior to the installation of these products.