



INSTALLATION OPERATING MAINTENANCE

QUIET-ONE  TM
2000

Kickspace Heater Series

Models:
KS 2004, KS 2006
KS 2008, KS 2010

Please read these instructions thoroughly before beginning your installation!

Smith's Quiet-One 2000 Series kickspace heaters are designed for installation in a forced hot water (hydronic) heating system. They may also be used with conventional gas, oil, electric, or solar powered water heaters.

IMPORTANT: BEFORE INSTALLING ANY HEATING TERMINAL UNIT TO A DOMESTIC WATER HEATER, CONSULT THE LOCAL PLUMBING CODES.

When installing a kickspace heater, an accurate heat loss calculation of the space is required. Match unit selection with BTUH output at system water temperature and flow rate. See the capacity chart below for output at various water temperatures and flow rates.

Unit	Flow Rate	Pressure	Entering Water Temperature (in degrees F) - BTU/hrs.								
	GPM	Drop (ft)	130	140	150	160	170	180	190	200	210
KS 2004	1	.06	2095	2410	2700	3000	3350	3650	3860	4000	4105
	3	.422	2240	2650	3000	3350	3765	4350	4350	4530	4635
	5	1.026	2350	2755	3140	3530	3940	4590	4590	4810	4935
KS 2006	1	.12	3410	4050	4655	5265	5860	6700	6700	7110	7270
	3	1.19	3735	4395	5060	5735	6330	7120	7120	7530	7790
	5	2.6	3860	4540	5225	5910	6560	7415	7415	7800	8010
KS 2008	1	.12	4300	5000	5765	6500	7370	8400	8400	8735	8920
	3	1.19	4580	5380	6195	7050	7930	9010	9010	9445	9740
	5	2.6	4760	5625	6450	7290	8200	9360	9360	9785	10020
KS 2010	1	.41	5530	6350	7150	7975	8780	9975	9975	10330	10520
	3	2.78	5880	6710	7740	8710	9625	11060	11060	11530	11740
	5	3.92	6070	7030	8000	9030	10025	11525	11525	11995	12180

- All capacities are rated by RTS with the kickspace installed under a cabinet and all capacities include the heat effect factor.
- For low speed ratings use: .85 for the KS2004, .75 for the KS2006, .70 for the KS2008 and .65 for the KS2010.
- Heat throw: KS2004 = 10' @ 50 CFM; KS2006 = 10' @ 75 CFM; KS2008 = 10' @ 90 CFM; KS2010 = 10' @ 125 CFM.

NOTE: All kickspace heaters include a low limit aquastat which shuts off power to the fan when water temperature falls to 110°F. Power is restored when water temperature rises to 130°F. When installing units with low temperature systems (radiant or water heater), it may be necessary to change the aquastat to a special (90°/110°F) low temperature unit (part #S10046).

UNIT INSPECTION

Before starting the installation, carefully remove the kickspace heater from its box. Inspect for any damage caused in handling. The box should include:

- (1) Kickspace unit
- (2) Molded grille endcaps (KS 2004 only)
- (2) Mounting screws
- (2) Screw covers

LOCATING THE KICKSPACE HEATER

Quiet-One 2000 Series kickspace units are designed for installation under kitchen cabinets, bathroom vanities, built-in shelves or benches, and stairways. An available recessed wall mounting kit enables vertical installation with a flush mounted grille. Consideration should be given in regards to perishable goods stored in the cabinet above the unit.

PREPARING THE SITE

Once the location has been selected, it will be necessary to cut a 15" X 15" opening in the bottom shelf of the cupboard. This piece should be saved for replacement after installation, and may be hinged to ease access to the unit.

NOTE: WHEN USING THE QUICK FIT HOSE KIT ACCESSORY ITEM, THIS STEP IS NOT REQUIRED. REFER TO SEPARATE SHEET FOR INSTRUCTIONS.

The front kickboard must be cut to the A and B dimension listed for each unit. The box that your kickspace heater came in has a handy template to ensure accurate cuts. Holes must be drilled in the floor or back wall of the cabinet to allow for supply and return piping (1/2") and electrical connection.

	<u>A</u>	<u>B</u>
KS 2004	14"	3 1/2"
KS 2006	18 1/2"	3 1/2"
KS 2008	18 1/2"	3 1/2"
KS 2010	22 1/8"	3 13/16"

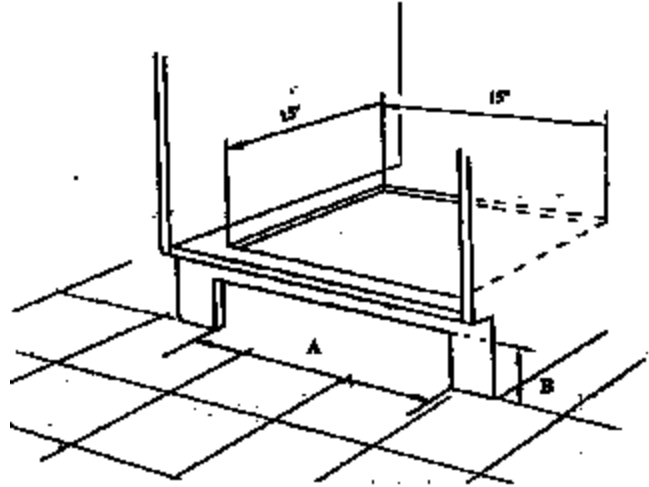

INSTALLING THE KICKSPACE HEATER

Place the molded grille endcaps on either side of the grille (KS 2004 only). Slide the kickspace unit backwards into the opening in the kickboard until the endcaps and grille are flush with the finished surface of the kickboard. Secure the unit with screws provided through holes in the endcaps (or grille), and place screw covers over the screws. Check to ensure that unit is both secure and level.

NOTE: UNLIKE COMPETITIVE MODELS, IT IS NOT NECESSARY TO SCREW THE QUIET-ONE UNITS TO THE FLOOR.

KS 2004



KS 2006, 2008, 2010



PIPING

Water supply and return connections are 1/2" copper tube. The water supply is the bottom tube and must be soldered first. After soldering the return connection (top tube), check that both connections are leak free.

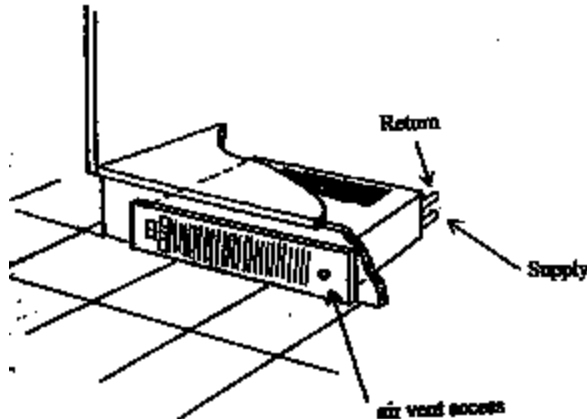

NOTE: ISOLATION VALVES ARE RECOMMENDED ON BOTH SUPPLY AND RETURN PIPING TO ALLOW FOR SERVICE AND BALANCING IF NECESSARY.

When filling the kickspace unit with system water, it will be necessary to remove the air from it. A built in bleeder air vent is accessible through the front of the unit by removing the rubber grommet. This vent may be operated with a screwdriver through the grille. Be careful as some water may be bled along with air. See diagrams for recommended piping arrangements.

Piping Diagrams

*Two Pipe
Reverse Return*

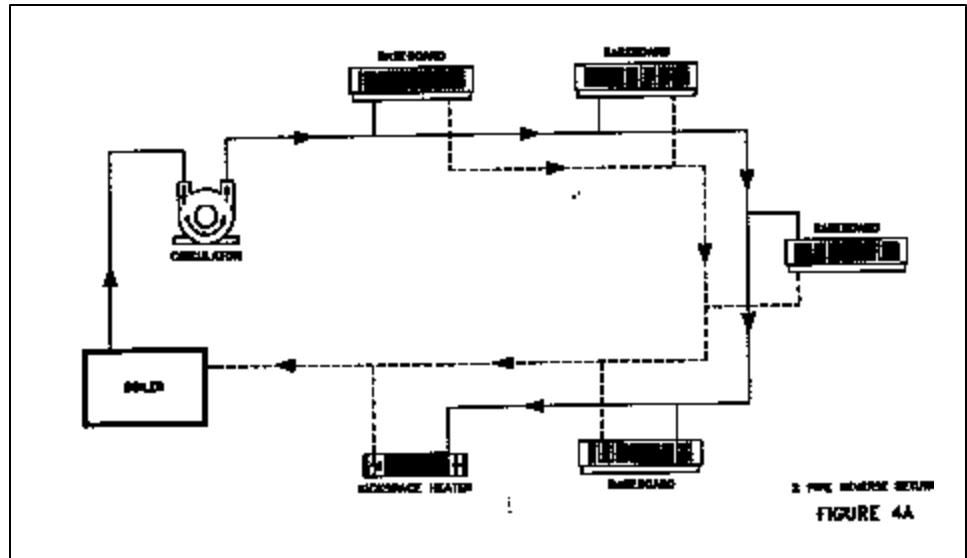

*One Pipe Series Loop
(Note: Monoflo fittings
may be required)*

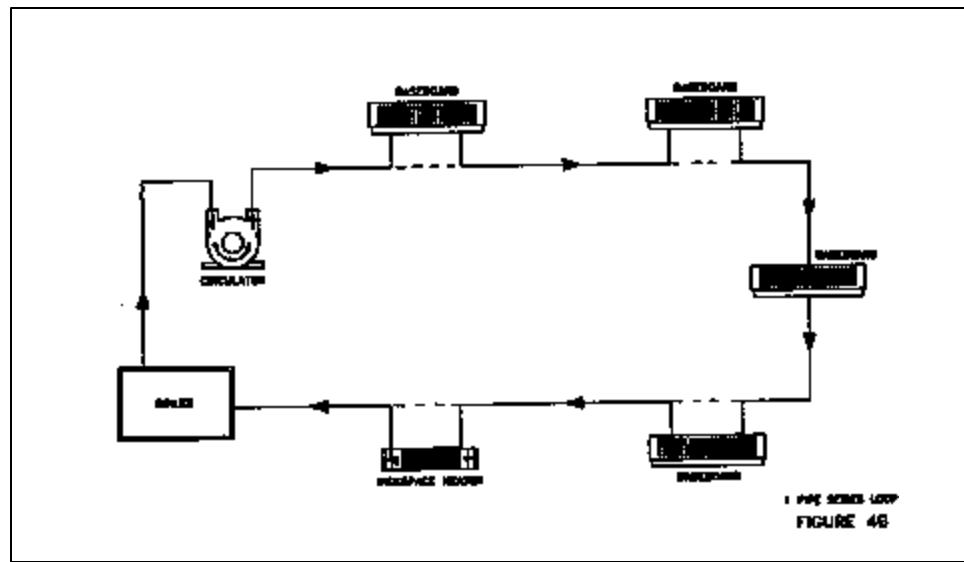

*Water Heater
As A Source*

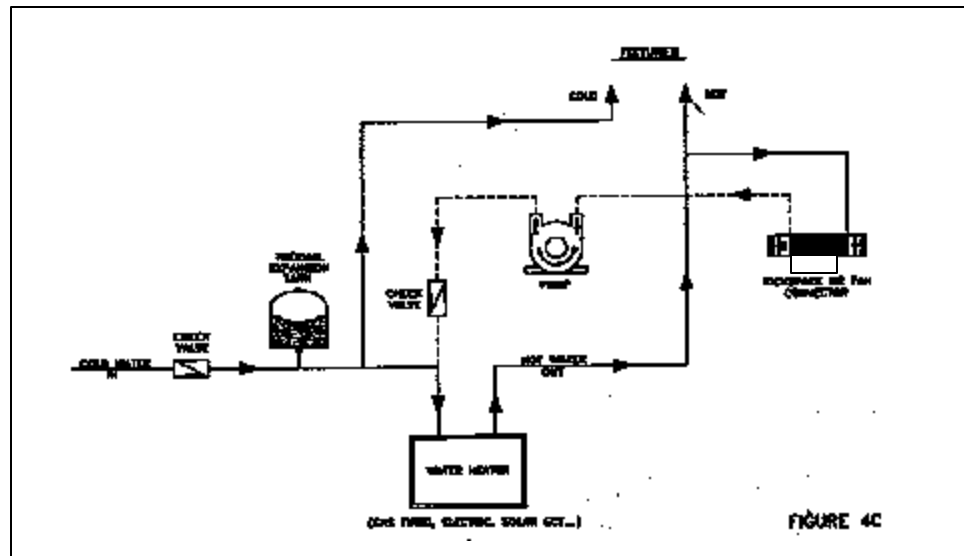

Replacement Parts

Part	Description	Replacement Part Number			
		KS 2004	KS2006	KS 2008	KS 2010
1	Coil	S10007	S10123	S10123	S10126
2 +	Grille	S10008	S10130	S10130	S10131
3 *	Fan motor	S10009	S10124	S10125	S10127
4 *	Outboard bearing	S10010	S10010	S10010	S10010
5 *	Blower wheel	S10011	S10011	S10011	S10128
6 **	Aquastat	S10012	S10012	S10012	S10012
7	Rocker switch	S10013	S10013	S10013	S10013

+ Grille parts for the KS 2004 are the end caps only.
 * Available as a complete unit (KS 2004-10229; KS 2006-10230; KS 2008-10231; KS 2010-10232).
 ** Available as a kit (Part #S10028 - 110°F-130°F)
 (Part #S10046 - 90°F-110°F)

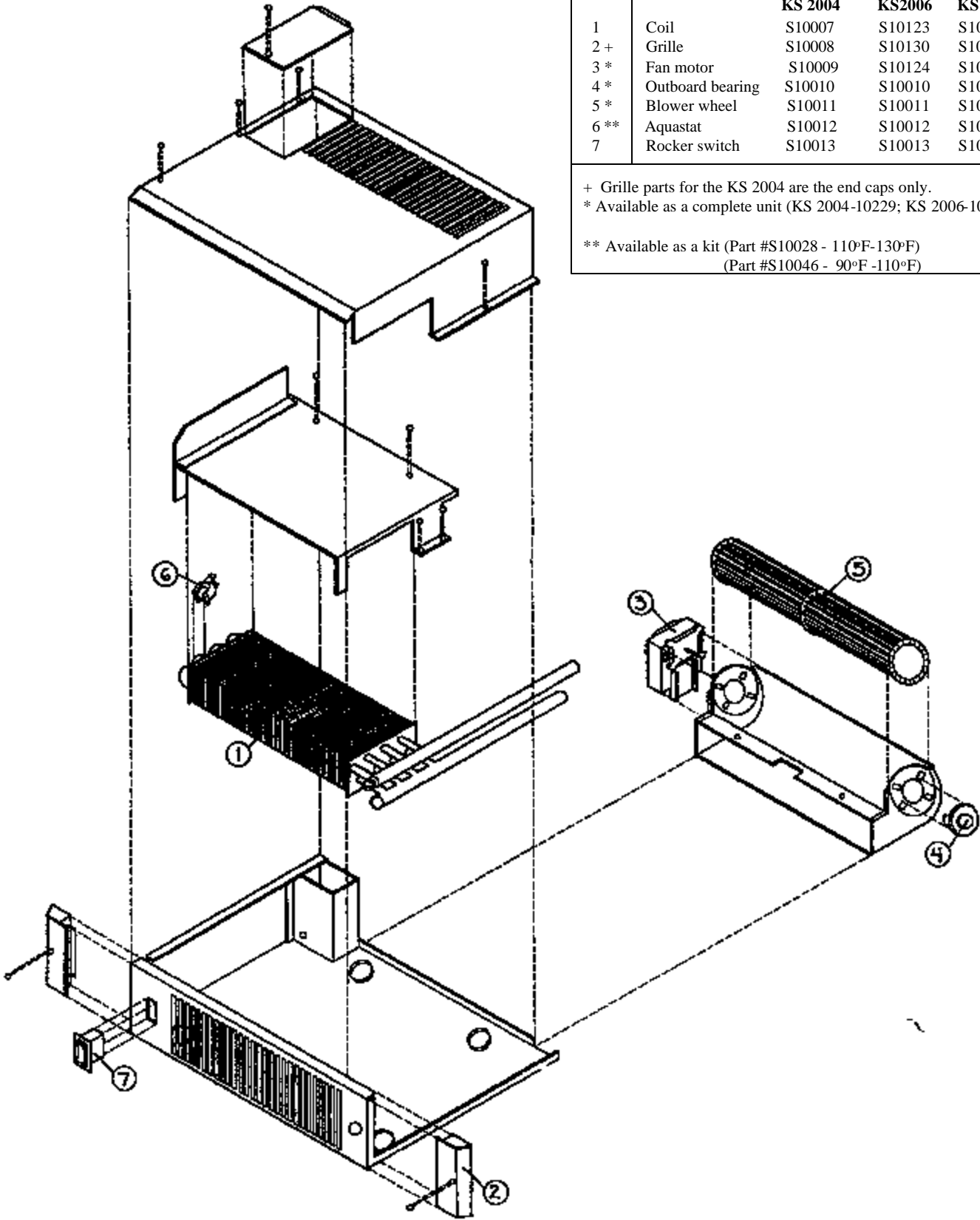

ELECTRICAL CONNECTIONS

ALL ELECTRICAL CONNECTIONS MUST COMPLY WITH LOCAL AND/OR NATIONAL REGULATIONS. IF IN DOUBT, CONSULT A QUALIFIED ELECTRICIAN.

Smith's Environmental Products' kickspace heaters are UL approved.

Remove the electrical junction box cover through the screw provided. There are two knockouts in the back and side of the junction box. Select the most convenient and bring wiring through it. **Supply conductors should be 14 AWG and protected by a 15 AMP over current protector.** Connect line input to black lead, neutral to white lead, and ground to pillar marked G inside the junction box. Refer to diagram below for complete wiring instructions.

Internal Wiring Diagram

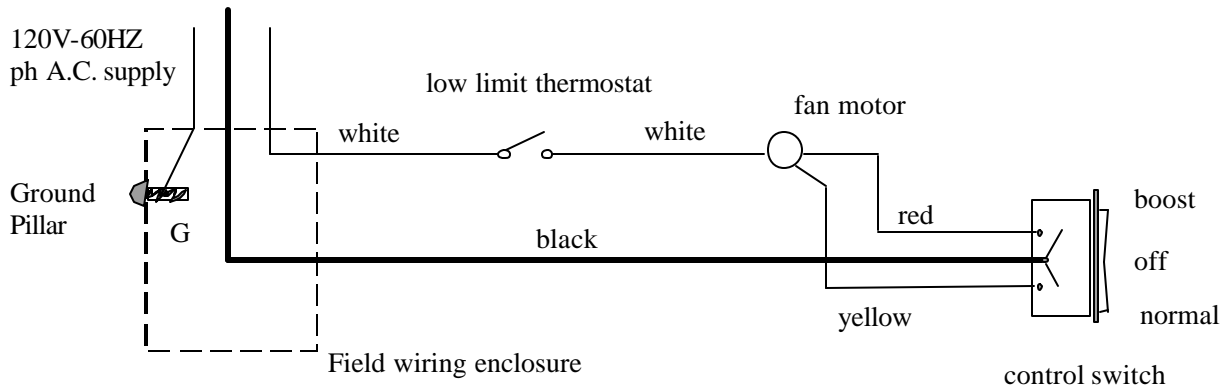

OPERATION

Before replacing the access cover in the cabinet bottom, ensure that the unit is operating properly. Activate the system thermostat and place speed switch on the front of the kickspace unit on MIN. Because of the low limit aquastat, it may take several minutes before the fan is activated. When the fan does come on, ensure that the switch is operational by moving position to OFF, then MAX. Best results are obtained by leaving the switch in the MIN position and reserving MAX for quick heat up or extreme conditions. If the unit is not operating, see troubleshooting tips at the end of this manual.

UNIT MAINTENANCE

The Quiet-One 2000 Series kickspace heaters are designed for years of trouble free operation with very little maintenance. It is recommended however that the unit be vacuumed occasionally through the front grille. This is especially important in areas with lots of dust, pet hair and dirt.

If servicing is required beyond this, contact the installing contractor or

Smith's Environmental Products

Customer Service

1875 Dewey Ave.

Benton Harbor, MI 49023

(269) 925-8818

www.smiths-env.com

TROUBLESHOOTING TIPS

If the kickspace heater fan does not operate:

1. Verify that supply voltage is 120 VAC, all wires are connected, and fan switch is in MIN or MAX position.
2. Verify that hot water is going to and through the unit at 130°F or above. Both supply and return pipes should be hot. An air bound coil will prevent the fan from operating. Bleed air from the coil if necessary.
3. By pass the low limit aquastat using a jumper wire. If the fan now runs, replace the aquastat.
4. If the fan does not run while the aquastat is jumped, replace the motor assembly.