

⚠ WARNING



Read and understand these instructions, and the warnings and instructions for all equipment and material being used before operating this tool to reduce the risk of property damage or serious personal injury.

SAVE THESE INSTRUCTIONS!

NOTICE Selection of appropriate materials and installation, joining and forming methods is the responsibility of the system designer and/or installer. Selection of improper materials and methods could cause system failure.

Stainless steel and other corrosion resistant materials can be contaminated during installation, joining and forming. This contamination could cause corrosion and premature failure. Careful evaluation of materials and methods for the specific service conditions, including chemical and temperature, should be completed before any installation is attempted.

If you have any questions concerning this RIDGID® product:

- Contact your local RIDGID distributor.
- Visit RIDGID.com to find your local RIDGID contact point.
- Contact Ridge Tool Technical Service Department at rttechservices.com, or in the U.S. and Canada call (800) 519-3456.

Description

The RIDGID® Precision Flare Tools are designed to form flares on steel, stainless steel, hard copper and brass tubing. The flare tools use an eccentric, needle bearing mounted flare cone to form the flare with less effort through a rolling action.

Precision Ratcheting and Non-Ratcheting Flare Tools have a clutch which automatically releases to iron and smooth the flare. The ratcheting flare tools include a reversible ratchet built into the feed screw handle.

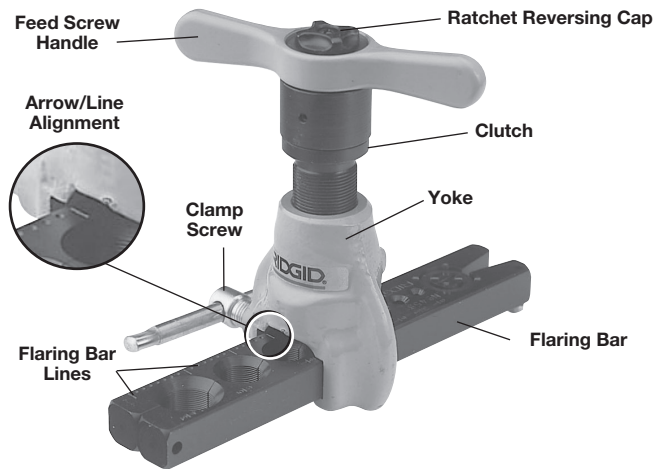

Figure 1 – Precision Ratcheting Flare Tools

Specifications

Precision Non-Ratcheting Flare Tools

Catalog No.	Model	Flare Type	Sizes	Weight	
				lb.	kg
41162	377	37° SAE	3/16, 1/4, 5/16, 3/8, 1/2, 5/8, 3/4"	4	1.6
50257	458MM	45° SAE	4, 4.75, 6, 8, 10, 12, 15, 16 mm	4	1.6
50262	458MMJ	45° SAE	4, 4.75, 6, 8, 10, 12, 15, 16 mm	4	1.6
41177	458 J	45° SAE	1/8, 3/16, 1/4, 5/16, 3/8, 1/2, 5/8, 3/4"	3.3	1.5
68302	456 J	45° R410A	1/4, 5/16, 3/8, 1/2, 5/8, 3/4"	3.3	1.5

Precision Ratcheting Flare Tools

Catalog No.	Model	Flare Type	Sizes	Weight	
				lb.	kg
42153	445R	45° SAE	1/4, 3/8, 1/2, 5/8, 3/4"	3.3	1.5
83037	458R	45° SAE	1/8, 3/16, 1/4, 5/16, 3/8, 1/2, 5/8, 3/4"	3.9	1.7
70677	456R	45° R410A	1/4, 5/16, 3/8, 1/2, 5/8, 3/4"	3.6	1.6

Max. Tube Wall Thickness..... 0.035" (0.9 mm)

Inspection/Maintenance

Clean equipment, including handle to aid inspection and improve control.

Inspect the flare tool for proper assembly, completeness, binding, wear or damage. Feed screw and clamp screw should move freely. If any problems are found, do not use until corrected. Only use with the assembled flaring bar – do not remove or interchange flaring bars to insure compatibility.

Lubricate screws and flaring bar hinge with a light weight general purpose lubricating oil. Wipe off any excess oil.

Set Up/Operation

1. Make sure tube end is cut square, reamed and free of burrs.
2. Loosen feed screw and clamp screw. Slide yoke to the hinged end of flaring bar. For the ratcheting flare tool, the ratcheting direction can be changed by rotating the reversing cap.
3. Open the flaring bar. If the flaring bar sticks closed, tighten clamp screw to force the flaring bar open.
4. Insert tube into proper size opening and close the flaring bar. Place the tube end even with top of flaring bar.

Flare diameter can be adjusting by placing tube end slightly above or below the top of flaring bar (Figure 2).

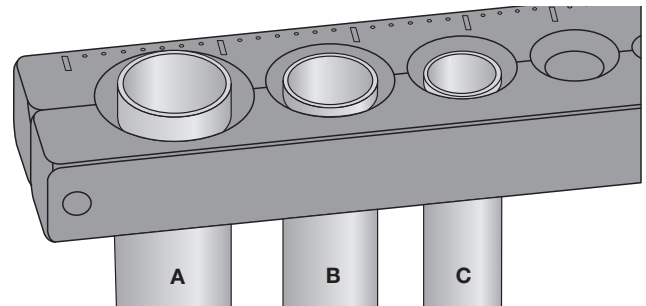

**Tube A – Increase Flare Diameter – Slightly Above
Tube B – Standard Flare – Even with Top
Tube C – Decrease Flare Diameter – Slightly Below**

Figure 2 – Tube Placement in Flare Bars

5. Slide yoke over tube to be flared. Align the arrow on the yoke with the appropriate line on the flaring bar (Figure 1).
Securely tighten clamp screw into the dimple in the side of the flaring bar, closing the flaring bar onto the tube.
6. Turn/ratchet the feed screw handle to bring the flare cone in contact with the end of the tube. Continue to turn/ratchet the handle to form the flare. Once the clutch releases, turn the handle at least two more full rotations to ensure a uniform, smooth flare surface.
7. Loosen the feed screw to retract the flare cone.
8. Loosen clamp screw. Slide yoke to the hinged end of flaring bar.
9. Open the flaring bar. If the flaring bar sticks closed, tighten clamp screw to force the flaring bar open.
10. Inspect the flare per the appropriate standard.