

**No. 458R**

Capacity: 1/8" through 3/4"

**No. FT-456R**

Capacity: 1/4" through 3/4"

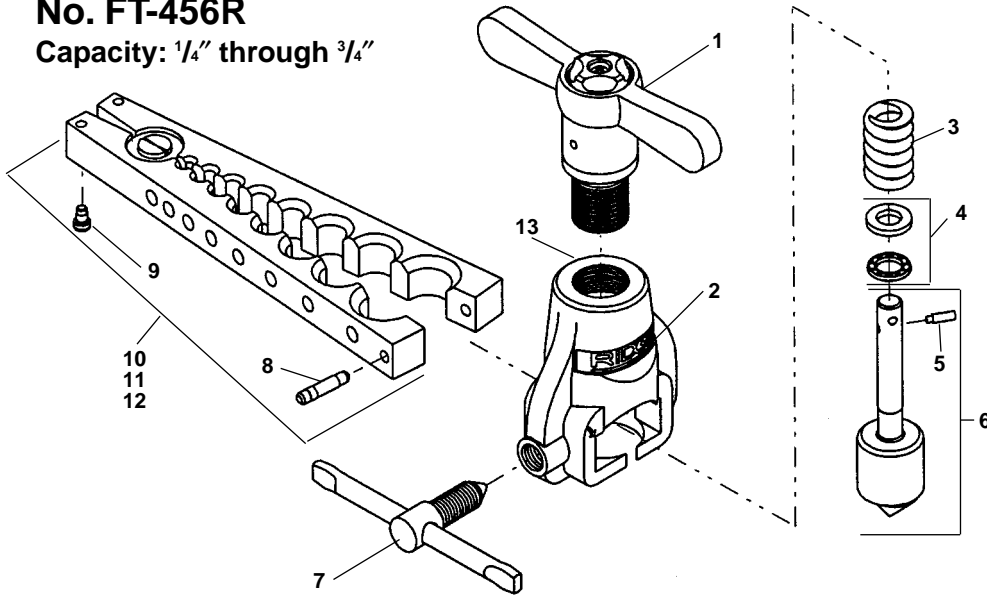

**NOTE: Order parts by Catalog Number only. DO NOT order by Reference Number.**

Ref. No.	Catalog No.	Description
—	70677	FT 456R Flare Tool F/Japan
—	83037	458R Flare Tool
1	83287	Ratchet Head Assembly
2	39722	Yoke Assembly
3	41485	Feed Spring
4	41520	Bearing Assembly
5	41505	Plunger Pin
6	41475	45° Shaft Assembly
7	41515	Clamp Screw Assembly
8	41455	Locating Pin
9	41450	Stop Pin
10	83282	FT 456R Flaring Bar Assembly
11	39727	458R Flaring Bar Assembly
12	50267	458mm Flaring Bar Assembly
13	76612	Plastic Washer - FT 456R

**Ratchet Head Assembly**

**45° Shaft Assembly**

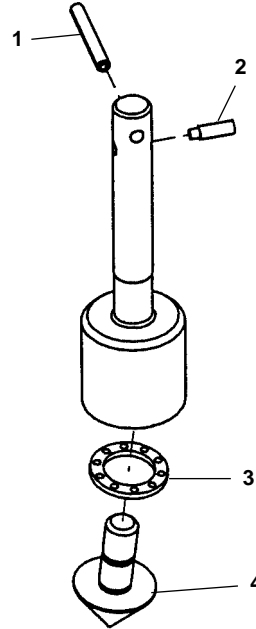
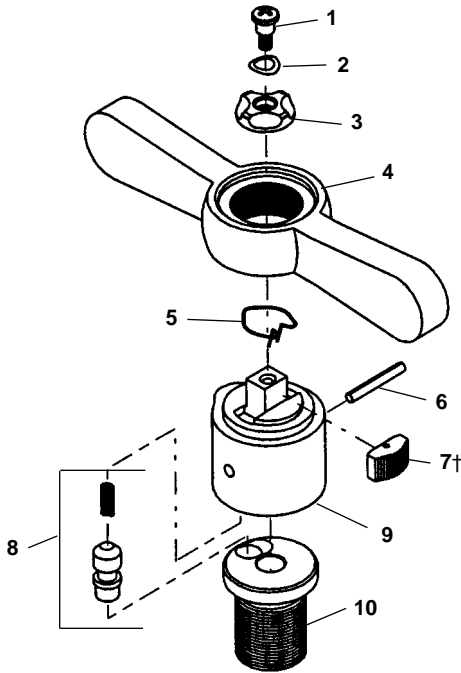

Ref. No.	Catalog No.	Description
—	83287	Ratchet Head Assembly
1	83232	Screw
2	83237	Wave Spring Washer
3	83242	Reversing Cap Assembly
4	83247	Ratchet Handle Assembly
5	83252	Pawl Spring
6	34400	Spring Pin
7†	83257	Pawl with Pawl Spring
8	83267	Square End Plunger Assembly
9	83362	Ratchet Adapter
10	83272	Ramp Style Feed Screw

Ref. No.	Catalog No.	Description
—	41475	45° Shaft Assembly
1	34400	Spring Pin
2	41505	Plunger Pin
3	41470	Thrust Bearing
4	41460	45° Cone

† Ref. 7 – Position Pawl with Dimple Side Up