

ANGLE 582 BRONZE

300 lb. SWP-600 lb. WOG† • General Service
Bronze Regrinding Disc • Union Bonnet • Gland Packed • Threaded Ends

Disc and stem integral on 1/8" through 1/2".

SPECIFICATIONS

| | |
|-----|--|
| 582 | Conforms to: MSS SP-80. Type 1, Class 300, Threaded Ends. |
|-----|--|

MATERIAL LIST

| NO. | PART | MATERIAL | SPECIFICATION |
|-----|-------------------------|------------|-------------------|
| 1 | Body | Bronze | ASTM B 61 |
| 2 | Bonnet | Bronze | ASTM B 61 |
| 3 | Disc | Bronze | ASTM B 61 |
| 4 | Stem | Bronze | ASTM B 61 |
| 5 | Union Bonnet Nut | Bronze | ASTM B 61 |
| 6 | Packing | Graphite | Commercial |
| 7 | Gland | Brass | ASTM B 124 C37700 |
| 8 | Packing Nut | Brass | ASTM B 16 |
| 9 | Handwheel | Mall. Iron | Commercial |
| 10 | Identification Plate | Aluminum | Commercial |
| 11 | Handwheel Nut | Brass | Commercial |
| 12 | Disc Ring | Brass | B 16 |

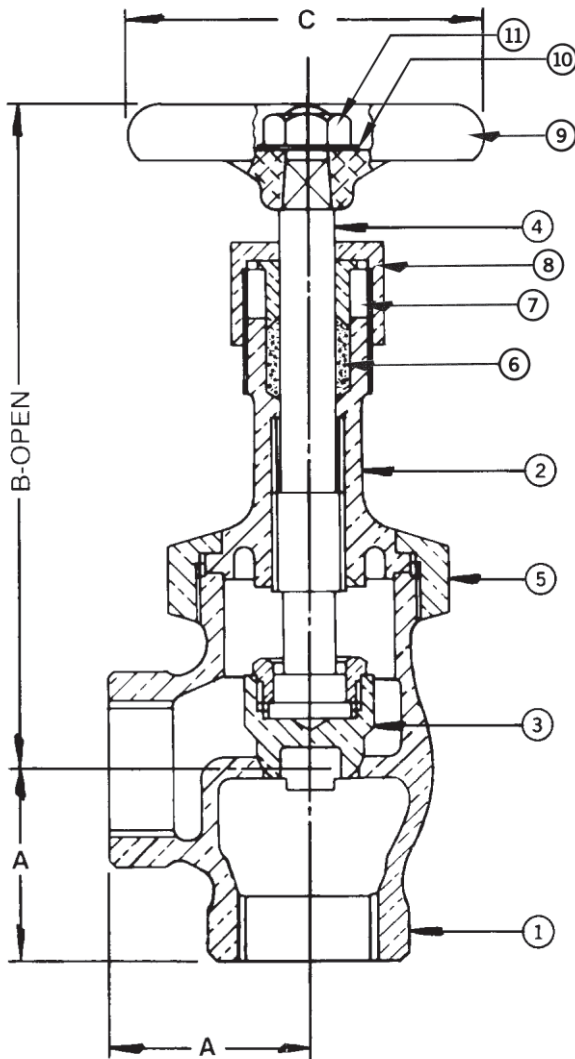

DIMENSIONS - INCHES / MILLIMETERS

| Units | Size | A | B | C | C _v |
|--------|-------|------|-------|-------|----------------|
| Inches | 1/4 | 1.06 | 4.00 | 2.25 | 1.60 |
| mm | 6.4 | 27.0 | 101.6 | 57.2 | 1.60 |
| Inches | 3/8 | 1.19 | 4.00 | 2.25 | 3.10 |
| mm | 9.5 | 30.2 | 101.6 | 57.2 | 3.10 |
| Inches | 1/2 | 1.25 | 4.50 | 2.50 | 5.10 |
| mm | 12.7 | 31.8 | 114.3 | 63.5 | 5.10 |
| Inches | 3/4 | 1.50 | 5.19 | 2.75 | 9.20 |
| mm | 19.1 | 38.1 | 131.8 | 69.9 | 9.20 |
| Inches | 1 | 1.75 | 6.38 | 3.25 | 16.00 |
| mm | 25.4 | 44.5 | 161.9 | 82.6 | 16.00 |
| Inches | 1 1/4 | 2.06 | 6.88 | 3.75 | 28.00 |
| mm | 31.8 | 52.4 | 174.6 | 95.3 | 28.00 |
| Inches | 1 1/2 | 2.25 | 7.50 | 4.25 | 39.00 |
| mm | 38.1 | 57.2 | 192.5 | 108.0 | 39.00 |
| Inches | 2 | 2.75 | 8.75 | 4.75 | 66.00 |
| mm | 50.8 | 69.9 | 222.3 | 120.7 | 66.00 |

† Non-Shock

Rev. 5

INNOVATION IN EVERY VALVE



MILWAUKEE VALVE

The information presented on this sheet is correct at the time of publication. Milwaukee Valve reserves the right to change design, and/or material specifications without notice. For the Installation, Operation and Maintenance Manual (IOM) see the engineering section on our website. For the most current information access www.milwaukeevalve.com

www.milwaukeevalve.com