

# GATE 2882A IRON

125 lb. SWP-200 lb. WOG† • Non-Rising Stem  
Solid Wedge Disc • Bolted Bonnet • Gland Packed • Flanged Ends

Flange shape and drilling to specification ASME B 16.1 (125 lb.)

## SPECIFICATIONS

2882A	Conforms to: MSS SP-70
-------	------------------------

## MATERIAL LIST

NO.	DESCRIPTION	MATERIAL & SPECIFICATION
1	Handwheel Nut	Steel
2	Identification Plate	Aluminum
3	Handwheel	Cast Iron ASTM A 126, Class B
4	Stem	Brass ASTM B 16
5	Gland Follower Nut	Bronze
6	Gland Follower	Cast Iron ASTM A 126, Class B
7	Gland Follower Bolt	Steel
8	Packing Gland	Brass ASTM B 16
9	Stuffing Box	Cast Iron ASTM A 126, Class B
10	Packing	Graphite Non-Asb. Fibers
11	Stuffing Box Gasket	Graphite Non-Asb. Fibers
12	Bonnet	Cast Iron ASTM A 126, Class B
13	Body Bolt	Steel
14	Body Gasket	Graphite Non-Asb. Fibers
15	Body Nut	Steel
16	Wedge Bushing	Cast Bronze ASTM B 62
17	Seat Ring	Cast Bronze ASTM B 62
18	Wedge Face Ring	Cast Bronze ASTM B 62
19 <sup>1</sup>	Wedge	Cast Iron ASTM A 126, Class B
20	Body	Cast Iron ASTM A 126, Class B
21	Stuffing Box Nut (not shown)	Bronze

<sup>1</sup> Sizes through 4" have bronze wedges. Sizes 5" through 12" made with cast iron wedge with bronze wedge face rings

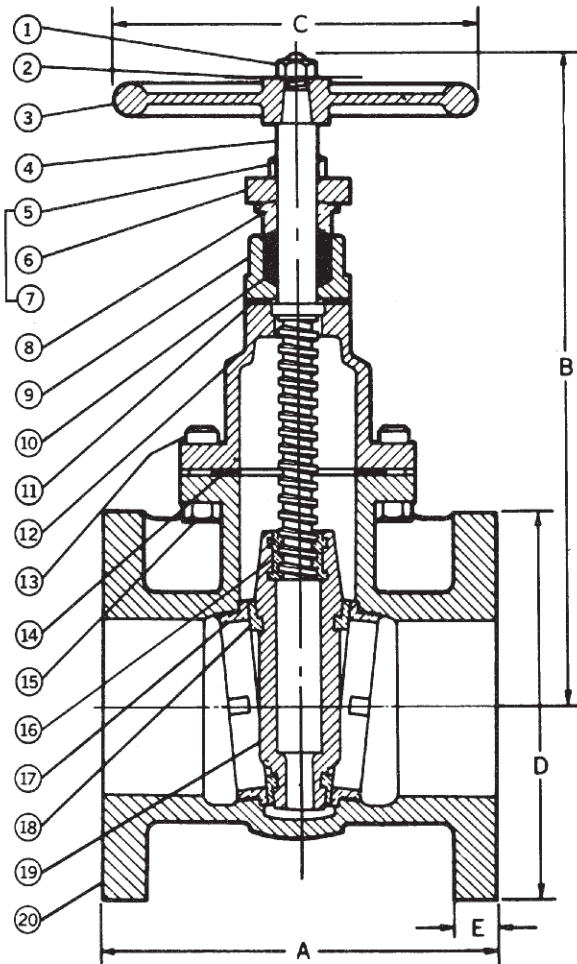

DIMENSIONS - INCHES / MILLIMETERS							
Units	Size	A	B	C	D	E	C <sub>v</sub>
Inches	2	7.00	12.00	7.00	6.00	0.63	215
mm	50.8	177.8	304.8	177.8	152.4	15.9	
Inches	2 1/2	7.50	13.25	7.00	7.00	0.69	335
mm	63.5	190.5	336.6	177.8	177.8	17.5	
Inches	3	8.00	13.50	8.00	7.50	0.75	510
mm	76.2	203.2	342.9	203.2	190.5	19.1	
Inches	4	9.00	17.00	10.00	9.00	0.94	945
mm	101.6	228.6	431.8	254.0	228.6	23.8	
Inches	5	10.00	18.00	12.00	10.00	0.94	1525
mm	127.0	254.0	457.2	304.8	254.0	23.8	
Inches	6	10.50	22.00	12.00	11.00	1.00	2250
mm	152.4	266.7	558.8	304.8	279.4	25.4	
Inches	8	11.50	26.50	14.00	13.50	1.13	4150
mm	203.2	292.1	673.1	355.6	342.9	28.6	
Inches	10	13.00	30.00	16.00	16.00	1.19	6700
mm	254.0	330.2	762.0	406.4	406.4	30.1	
Inches	12	14.00	35.00	18.00	19.00	1.25	9925
mm	304.8	355.6	889.0	457.2	482.6	31.8	

† Non-Shock

Rev. 4

**INNOVATION** IN EVERY VALVE



**MILWAUKEE VALVE**

www.milwaukeevalve.com

The information presented on this sheet is correct at the time of publication. Milwaukee Valve reserves the right to change design, and/or material specifications without notice. For the Installation, Operation and Maintenance Manual (IOM) see the engineering section on our website. For the most current information access www.milwaukeevalve.com