

Super Centurion® 250 Fire Hydrant

Mueller Co.



PRODUCT FEATURES

- 3-way and 4-way hydrant: 250psig/17barg maximum working pressure, 500psig/34barg test pressure.*
- UL Listed and FM Approved (CE marked to EN14384 available).
- Meets or exceeds all applicable requirements of ANSI/AWWA C502 and ANSI/NSF 61/372.
- O-ring sealed Bonnet, Ground, and Shoe Flange – better leak resistance, easier maintenance.
- O-ring sealed Oil Reservoir with Filler Plug – permits easy check of oil level and refill without removing Bonnet; filled at factory.
- Automatic operating mechanism lubrication – positive lubrication of stem threads and bearing surfaces each time hydrant is operated.
- Super Centurion 350 Hydrants with 350psig/24barg maximum working pressure, 700psig/48barg test pressure available.
- Full flow performance – large radius hose and pumper openings and conical Upper Valve Plate reduce turbulence and provide low friction loss.
- Field replaceable, O-ring sealed Hose and Pumper Nozzles – threaded in place and retained by stainless steel locks – NST or BSP threads. Integral Storz connector also available to order.
- O-ring sealed Bronze Seat Ring – Resists corrosion and easily removed for maintenance through top of hydrant.
- Traffic Flange and stainless steel Stem Coupling – if hydrant is hit, flange and coupling break free preventing damage to stem and main valve, and uncontrolled water flow – coupling will not break into pieces that could drop down and affect valve operation.
- Double Bronze Drains – each time main valve opens or closes, drain valves force-flush drain openings to keep them open for barrel drainage.
- Inlet Connections: 6"/DN150 Flanged ANSI B16.1 Class 125 Flat Face (optional PN10, PN16 drilling).

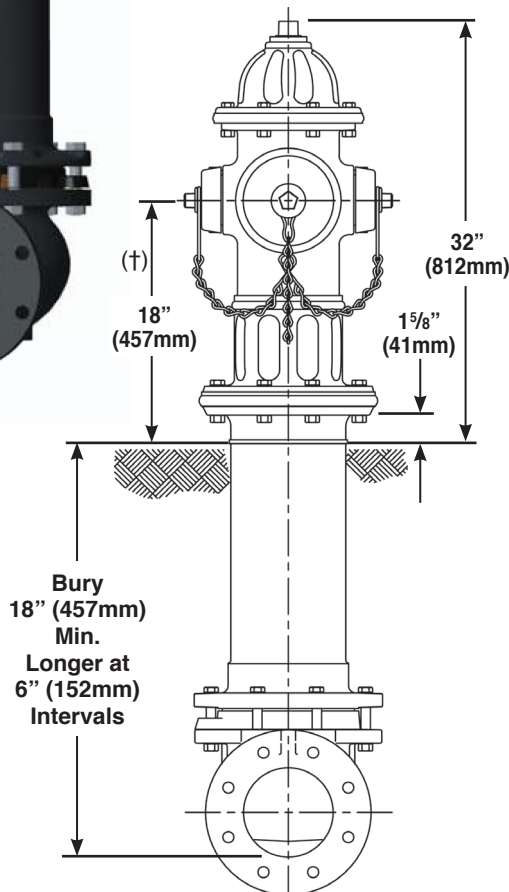

AVAILABLE AS: 3-HOSE, 4-HOSE, 3-HOSE AND 1-PUMPER; 2-HOSE AND 2-PUMPER CONFIGURATIONS

- A421 4 1/2" (114mm) main valve opening 3-way (2-hose nozzle/1-pumper nozzle)
- A423 5 1/4" (133mm) main valve opening 3-way (2-hose nozzle/1-pumper nozzle)
- A454 5 1/4" (133mm) main valve opening 3-way (3-hose nozzle)**
- A455 5 1/4" (133mm) main valve opening 4-way (4-hose nozzle)**
- A458 5 1/4" (133mm) main valve opening 4-way (3-hose nozzle/1-pumper nozzle)**
- A459 5 1/4" (133mm) main valve opening 4-way (2-hose nozzle/2-pumper nozzle), UL Listed and ANSI/AWWA C502



*2-way is a 200psig/12barg rated Centurion Hydrant.

**Hose Gate Valves required on FM Approved Models.

† Tall snow bury version (24"/600mm) available. Details upon request.

Super Centurion® 250 Fire Hydrant



PARTS LIST

ID	PART NAME	MATERIAL
A-1 ¹	Operating Nut	Bronze ASTM B584
A-3	Hold Down Nut O-Ring	Rubber ASTM D2000 BUNA N
A-5	Bonnet O-Ring	Rubber ASTM D2000 BUNA N
A-6	Anti-Friction Washer	Acetal
A-7	Oil Filler Plug	Brass ASTM B16
A-8	Bonnet	Cast Iron ASTM A126 CL.B
A-9	Bonnet Bolt & Nut	Steel J429 GR. 2
A-10	Upper Barrel O-Ring ²	Rubber ASTM D2000 BUNA N
A-11	Upper Stem	Steel ASTM A576 GR.1117
A-12	Stem O-Ring	Rubber ASTM D2000 BUNA N
A-13	Nozzle Lock	Stainless Steel ASTM A276
A-14	Pumper Nozzle	Bronze ASTM B584
A-15	Pumper Nozzle Cap Gasket	Rubber ASTM D2000 Neoprene
A-16	Pumper Nozzle O-Ring	Rubber ASTM D2000 BUNA N
A-17	Pumper Nozzle Cap	Cast Iron ASTM A126 CL.B
A-18	Hose Nozzle	Bronze ASTM B584
A-19	Hose Nozzle Gasket	Rubber ASTM D2000 Neoprene
A-20	Hose Nozzle O-Ring	Rubber ASTM D2000 BUNA N
A-21	Hose Nozzle Cap	Cast Iron ASTM A126 CL.B
A-22	Cap Chain	Plated Steel
A-23	Chain Hook	Plated Steel
A-24	Upper Barrel	Cast Iron ASTM A126 CL.B
A-25	Stem Coupling	Stainless Steel ASTM A890
A-26	Traffic Flange Bolt & Nut	Steel SAE J429 GR. 2
A-27	Traffic Flange O-Ring ³	Rubber ASTM D2000 BUNA N
A-28	Traffic Flange	Cast Iron ASTM A126 CL.B
A-29	Cotter Pin	Stainless Steel ASTM A276
A-30	Clevis Pin	Stainless Steel ASTM A276
A-31	Lower Stem	Steel ASTM A576 GR.1144
A-32	Lower Barrel	Cast Iron ASTM A126 CL.B
A-33	Stem Pin	Stainless Steel ASTM A582
A-34	Drain Valve Facing	Plastic
A-35	Drain Valve Screw	Stainless Steel
A-36	Upper Valve Plate	Bronze ASTM B584
A-37	Shoe Bolt & Nut	Steel SAE J429 GR. 2
A-38	Drain Ring Housing O-Ring ⁴	Rubber ASTM D2000 BUNA N
A-39	Top Seat O-Ring	Rubber ASTM D2000 BUNA N
A-40	Drain Ring Housing	Cast Iron ASTM A126 CL.B
A-41	Drain Ring Housing Nut/Bolt ⁵	Steel ASTM A307 Plated
A-42	Drain Ring	Bronze ASTM B584
A-43	Seat Ring	Bronze ASTM B584
A-44	Bottom Seat O-Ring	Rubber ASTM D2000 BUNA N
A-45	Reversible Main Valve ⁶	Rubber ASTM D2000 SBR
A-46	Lower Valve Plate ⁷	Cast Iron ASTM A126 CL.B
A-47	Cap Nut Seal	Rubber ASTM D2000 BUNA N
A-48	Lock Washer	Stainless Steel ASTM A276
A-49	Lower Valve Plate Nut	Cast Iron ASTM A126 CL.B
A-50	Shoe ⁸ – Flanged	Cast Iron ASTM A126 CL.B
A-84 ¹	Hold Down Nut	Bronze ASTM B584
A-85 ¹	Weather Seal	Rubber ASTM D2000 EPDM
A-51	10.5 oz. Hydrant Lubricating Oil	(not shown)

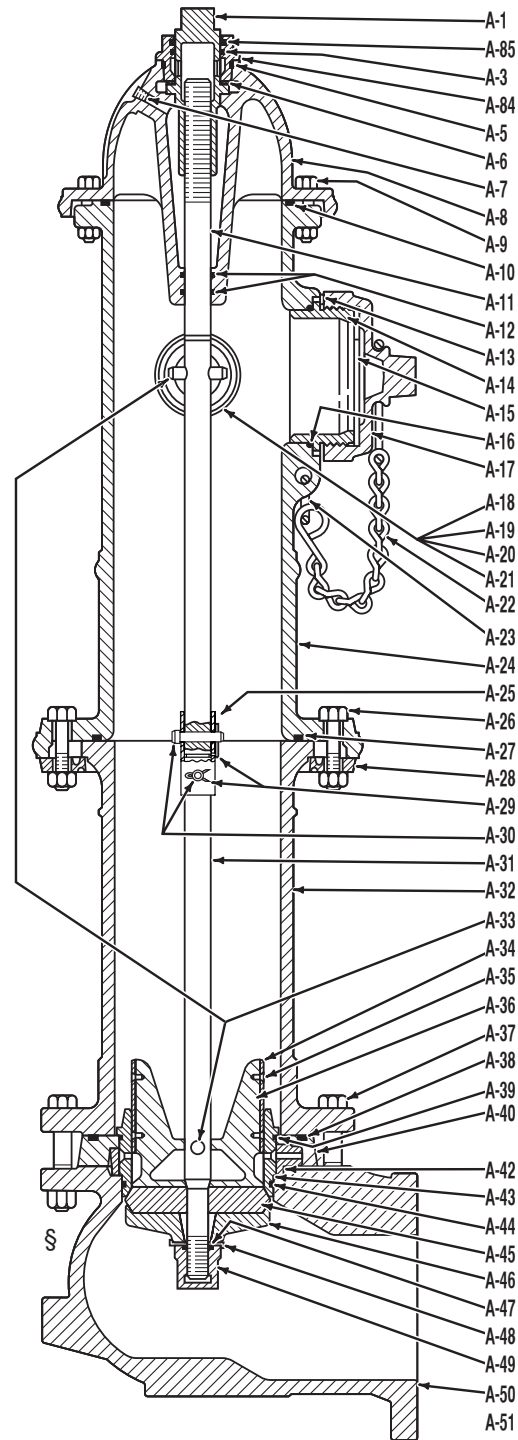

- 1 – 1988 & newer models; all pre-1988 models use parts A-2 Weather Cap & A-4 Hold Down Nut. These parts are not shown & must be used with a pre-1988 style Operating Nut, A-1.
- 2 – 1997 & newer 3-way models; all pre-1997 models have flat gasket
- 3 – 1997 & newer models; all pre-1997 models have flat gasket
- 4 – 1997 & newer models; all pre-1997 models have square gasket
- 5 – Used only on pre-1997 model hydrant – Not Shown
- 6 – 1997 & newer models only; pre-1997 models use non-reversible main valve & lower valve plate – Not Shown
- 7 – 1997 & newer models for reversible main valve; pre-1997 models use non-reversible main valve – Not Shown
- 8 – 6" MJ Shoe is Ductile Iron, ASTM A536

Nozzle Information:

- 1/Pumper Nozzle (4 1/2"/DN110 NST or BSP)
- 2/Hose Nozzles (2 1/2"/DN65 NST or BSP)



Copyright © 2017 Mueller Co., LLC. All Rights Reserved. The trademarks, logos and service marks displayed in this document herein are the property of Mueller Co., LLC, its affiliates or other third parties. Products marked with a section symbol (§) are subject to patents or patent applications. For details, visit www.mwppat.com. These products are intended for use in potable water applications. Please contact your Mueller Sales or Customer Service Representative concerning any other application(s).