



INSTALLATION, OPERATION & MAINTENANCE INSTRUCTIONS

1455 Kleppe Lane ♦ Sparks, NV 89431-6467 ♦ (775) 359-4712 ♦ Fax (775) 359-7424
E-mail: haws@hawsco.com ♦ website: www.hawsco.com

No. 2076860(17)

Model 1435 Drinking Fountain

NOTE TO INSTALLER: Please leave this information with the Maintenance Department.

LIMITED WARRANTY

HAWS warrants that this specific product is guaranteed against defective material or poor workmanship for a period of **one year from date of shipment**. HAWS liability under this warranty shall be discharged by furnishing without charge F.O.B. HAWS Factory any goods, or part thereof, which shall appear to the Company upon inspection to be of defective material or not of first class workmanship, provided that claim is made in writing to Haws within a reasonable period after receipt of the product. Where claims for defects are made, the defective part or parts shall be delivered to the Company, prepaid, for inspection. HAWS will not be liable for the cost of repairs, alterations or replacements, or for any expense connected therewith made by the owner or his agents, except upon written authority from HAWS, Sparks, Nevada. HAWS will not be liable for any damages caused by defective materials or poor workmanship, except for replacements, as provided above. Buyer agrees that HAWS shall not be liable for general, special, or consequential damages claimed to arise under the contract of sale. The drinking fountain manufactured by HAWS is warranted to function if installation and maintenance instructions provided are adhered to. The units also must be used for the purpose for which they were intended.

**NO OTHER WARRANTIES EXPRESSED OR IMPLIED ARE AUTHORIZED,
PROVIDED OR GIVEN BY HAWS.**

**SHOULD YOU EXPERIENCE DIFFICULTY WITH THE INSTALLATION OF THIS
MODEL PLEASE CALL:**

TECHNICAL SUPPORT: 1-800-766-5612

FOR CUSTOMER SERVICE: 1-888-640-4297

RECOMMENDED TOOLS: Hack saw, pipe joint sealant, screwdriver, level, 12" adjustable wrench, 10" pipe wrench, 5/64" and 5/32" hex key wrench, 9/16", 1/2", 7/16" socket wrench or open-end wrench.

LOCATION OF UNIT: When installing this unit, local, state or federal codes should be adhered to. (If height other than shown is required, then dimensions must be adjusted accordingly).

SUPPLY LINE: The minimum recommended line size is 1/2" IPS with 30-90 PSI (2-6 ATM) flowing pressure. Where sediment or mineral content is a problem, an inlet filter is recommended.

PLUMBING CONNECTIONS: Inlet is 3/8" O.D. tube fitting. Waste outlet is female 1-1/2" IPS.

MAINTENANCE: Periodically clean the strainer. Refer to 5874 Series Valve Manual for more information.

INSTALLATION PROCEDURE

GENERAL NOTES:

1. For all plastic push-in type fitting connections, only connect NSF-61 copper or plastic tubing. Stainless steel or glass tubing is not recommended. The following assembly instructions must be followed to ensure a watertight connection:
 - a. Cut tubing square and clean.
 - b. Mark from end of tube the length of insertion (See table below).
 - c. Push tube into the fitting until it bottoms out.
 - d. To remove, depress collet and pull tubing out.

Tube Sizes	O.D. Tolerance	Insertion Depth
1/4"	±.005"	11/16"
3/8"	±.005"	3/4"
1/2"	±.005"	7/8"

Refer to Installation drawing for mounting. For assembly steps below refer to exploded view in Parts Breakdown drawing.

STEP 1: Remove nut and washers from bubbler heads. Install bubbler heads through receptor. Install, respectively, rubber washer, fiber washer and nut onto bubbler shank. Securely tighten nut.

STEP 2: Remove pushbutton assembly from valve with spanner wrench provided. Be sure to also remove (chrome plated) ring nut and (chrome plated) washer from valve. At this point, carefully follow installation instructions shown on **5874 Series Valve/Push Button Operation and Maintenance Manual** under heading: **"INSTALLATION INSTRUCTIONS FOR 5874PB"**

INSTALLATION PROCEDURE

- STEP 3:** Make tubing connections from bubbler to the outlet side of control valve (Refer to Installation drawing). Follow instructions for tubing preparation, and insertion depths from Step 3.
- STEP 4:** Place strainer into receptor, using putty; secure in place using fiber washer and lock nut.
- STEP 5:**
1. Attach mounting brackets to wall using 3/8-16 mounting hardware (not supplied); **Hand tighten only** at this point.
 2. Align bowl over brackets such that bowl alignment tabs slide into slots at tops of brackets and bottom bowl tabs slide between or around brackets.
 3. Adjust brackets as needed to align bracket slots with bowl bottom tab holes and attach bowl to brackets using (1) 1/4-20 screw, (2) 1/4 ID Fender washers, (1) 1/4-20 hex nut per bracket. Insert mounting hardware such that screw heads cover holes in bowl bottom tabs, and Fender washers & nuts cover bracket slots; **Hand tighten only** at this point.
 4. Level bowl and **fully tighten** all mounting hardware such that bowl does not move when rocked up and down, nor move away from wall when pulled on.
- STEP 6:** Flush supply line to clear debris. Connect to a 1/2" IPS supply line and tighten.
- STEP 7:** Connect waste trap (supplied) to 1-1/2" IPS waste pipe (not supplied).
- STEP 8:** Completely open the screwdriver stop (not supplied) and check for leaks.
- STEP 9:** Adjust valves for desired flow height. See 5874 Series Valve Manual (supplied).
- STEP 10:** Attach bottom plate to fountain using #10-24 hardware provided.

TROUBLESHOOTING			
PROBLEM		REPAIR CHECKLIST	
1.	Insufficient bubbler flow.	1a.	Check that inlet screwdriver stop valve is in wide-open position.
		b.	Verify minimum 30 psi flowing supply pressure.
		c.	Clean strainer. See 5874 Series Valve Manual.
		d.	Adjust valve to increase flow. Use front adjust screw or see 5874 Series Valve Manual.

For more information about Haws products, see our website: www.hawsc.com

NOTES:

- 1 APPLY ONE DOT OF LOCTITE 222MS THREADLOCKER ON FEMALE THREADS OF PUSH BUTTON. SEE 5874 SERIES OPERATION AND MAINTENANCE MANUAL FOR PROPER APPLICATION PROCEDURE.
- 2 5874PB INCLUDES VRK5874 CARTRIDGE ASSEMBLY (NOT SHOWN) AND PBA7 PUSHBUTTON.
- 3 REFER TO 5874 SERIES/VRK5874 OPERATION AND MAINTENANCE MANUAL FOR INSTALLATION INSTRUCTIONS.
4. FOR TUBING ROUTING AND LENGTHS SEE SHEET 2 OF INSTALLATION DRAWING.

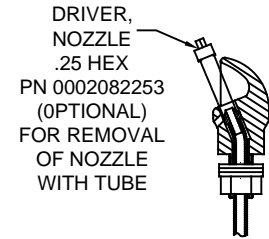

VIEW A
DETAIL OF 5703M

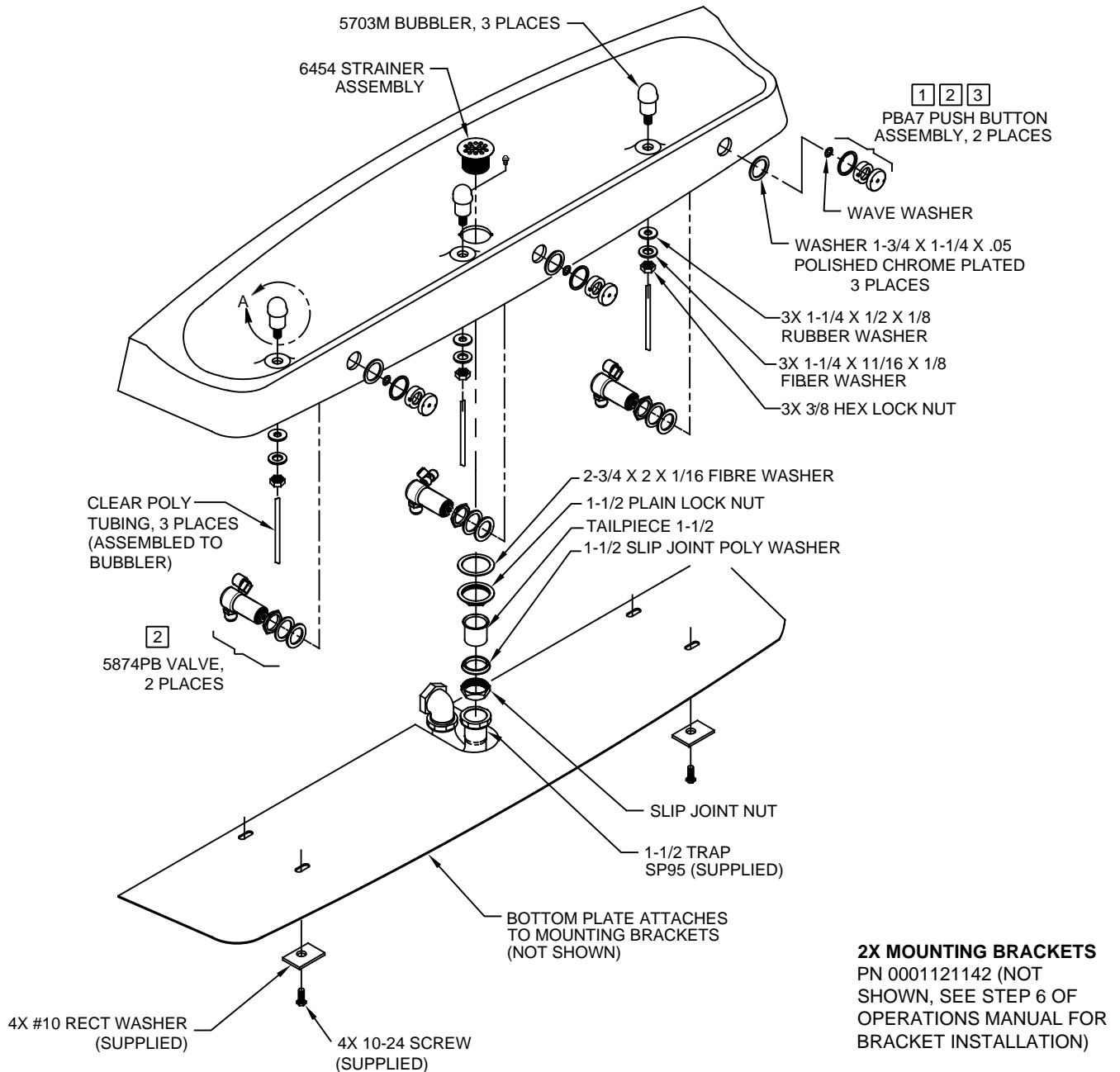

2X MOUNTING BRACKETS
PN 0001121142 (NOT SHOWN, SEE STEP 6 OF OPERATIONS MANUAL FOR BRACKET INSTALLATION)

PARTS BREAKDOWN

		Haws [®]		1455 KLEPPE LANE SPARKS, NEVADA 89431 (775) 359-4712 FAX (775) 359-7424 E-MAIL: HAWS@HAWS.CO.COM WEBSITE: WWW.HAWS.CO.COM				
				ECN NO. REVISED PER BY ECN: 5188 VWC	MODEL(S) 1435 THREE-BUBBLER FOUNTAIN	PART NUMBER 0002076860		
DRAWN D.OLLOM	DATE 08/29/97	CHKD VWC	APPROVED FV	DATE 07/06/17	SCALE: 1:14	DRAWING TYPE: PARTS BREAKDOWN	SIZE: A	SHEET 1 OF 1
WHEN ORDERING PARTS PLEASE SPECIFY MODEL NUMBER.				REVISION 17				

NOTES:

1. ROUGH-IN DIMENSIONS MAY VARY $\pm 1/4"$ (6.4mm)
2. WHEN INSTALLING THIS UNIT LOCAL, STATE OR FEDERAL CODES SHOULD BE ADHERED TO. FOR INSTALLATION HEIGHTS OTHER THAN SHOWN, DIMENSIONS MARKED (*) MUST BE ADJUSTED ACCORDINGLY.
- 3 REFER TO 5874 SERIES OPERATION AND MAINTENANCE MANUAL FOR PUSH BUTTON AND VALVE INSTALLATION/MAINTENANCE INSTRUCTIONS.

(NOTES CONTINUED ON SHEET 2 OF 2)

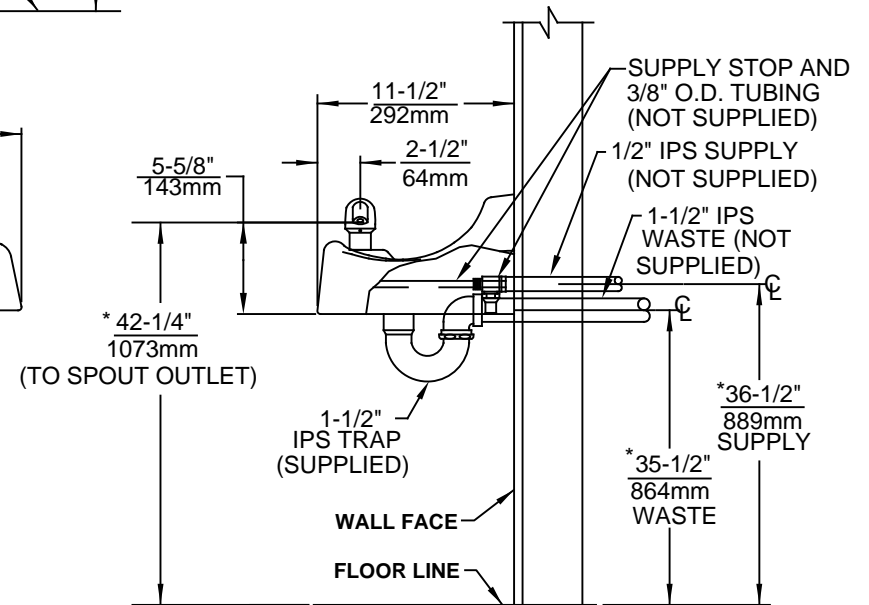
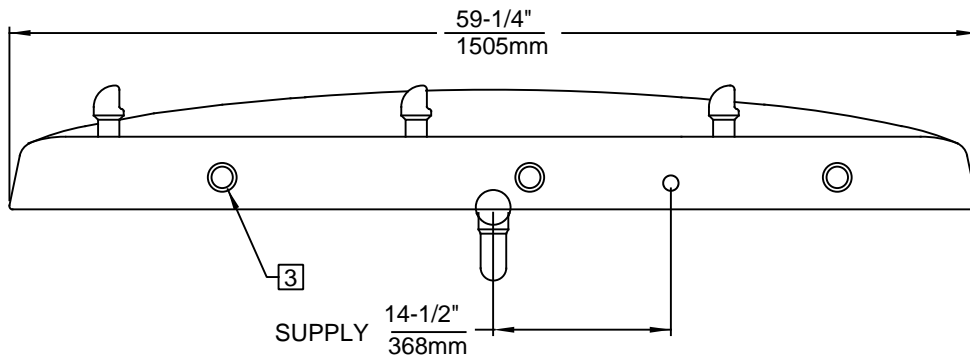
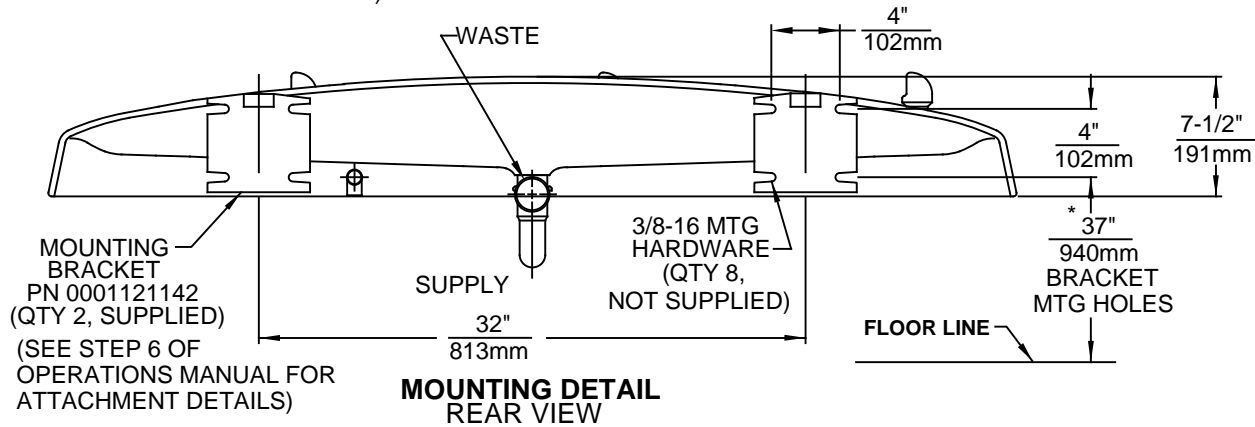

1455 KLEPPE LANE
SPARKS, NEVADA 89431
(775) 359-4712 FAX (775) 359-7424
E-MAIL: HAWS@HAWSCO.COM
WEBSITE: WWW.HAWSCO.COM

ECN NO. REVISED PER BY:		MODEL(S)		PART NUMBER	
. ECN: 5188 JP		1435		0002076860.D	
DRAWN:	DATE:	CHKD.:	REVISION		
CJL	01-01-91	VWC	17		
APPROVED:	DATE:	SCALE: 1:11		DRAWING TYPE:	SHEET 1 OF 2
FV	07/06/17			INSTALLATION	

NOTES: (CONTINUED)

4. CONNECT WHITE "POLYPROPYLENE" TUBING ON PRESSURE SIDE (INLET) OF VALVE.
5. CONNECT CLEAR "POLYETHYLENE" TUBING ON FREE FLOW SIDE (VALVE TO BUBBLER HEAD) ONLY.

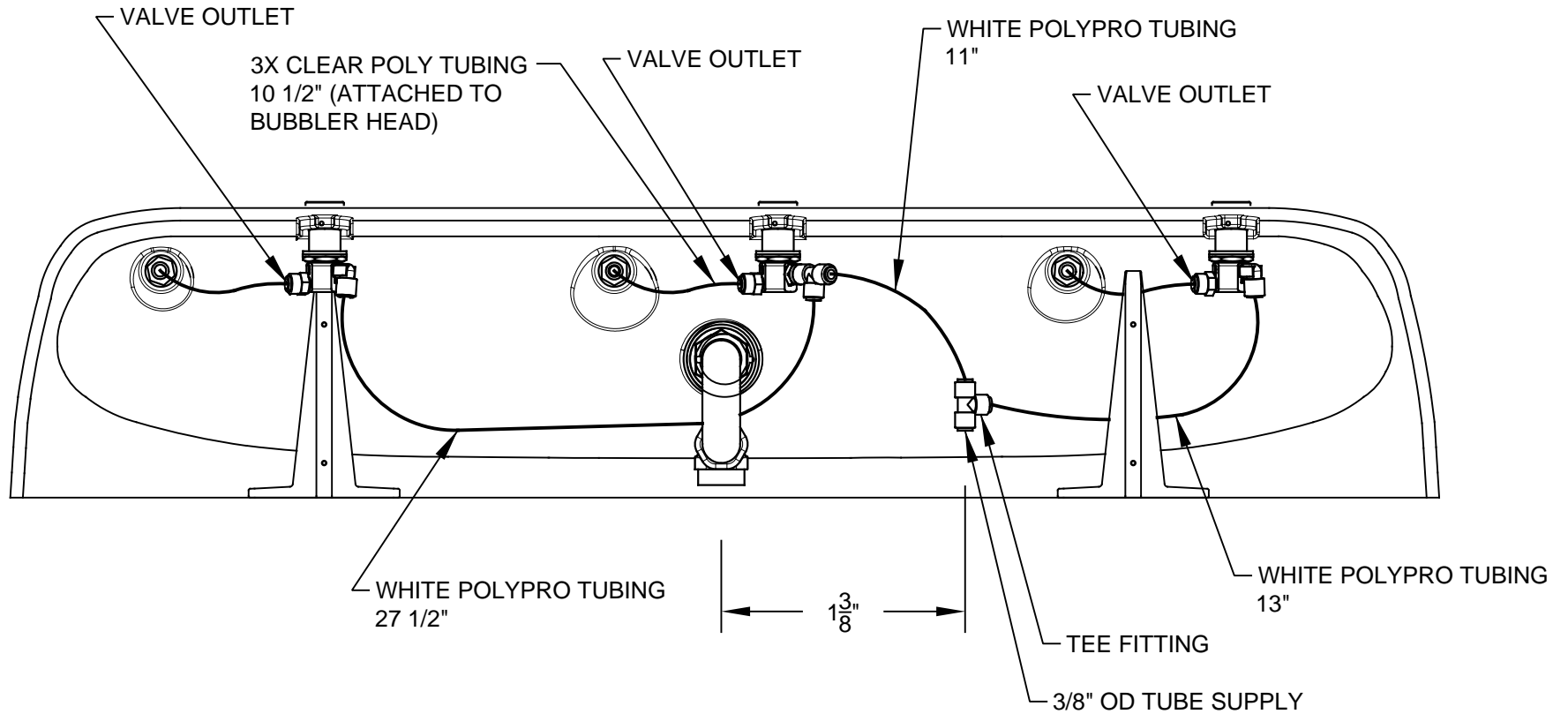

TUBING ROUTING DETAIL
BOTTOM VIEW

		Haws [®]		1455 KLEPPE LANE SPARKS, NEVADA 89431 (775) 359-4712 FAX (775) 359-7424 E-MAIL: HAWS@HAWS.CO.COM WEBSITE: WWW.HAWS.CO.COM	
				ECN NO. 5188 DRAWN: CJL APPROVED: FV	REVISED PER: JP DATE: 11-01-91 DATE: 07/06/17
SCALE: 1:11		DRAWING TYPE: INSTALLATION		SIZE: A SHEET 2 OF 2	