

6030CT – A² COMPOSITE TUB

60 x 30 x 15 inches



FEATURES

- Pre-leveled base
- Slip resistant, textured bottom
- Available in White & Biscuit only
- Left, right drain
- Durable high gloss finish
- 15-year residential limited warranty

AQUATIC ADVANTAGE

- National distribution
- 6 manufacturing facilities
- Private fleet
- Centralized customer service
- Field support



6030CT

60 x 30 x 15
inches

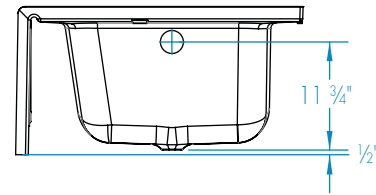
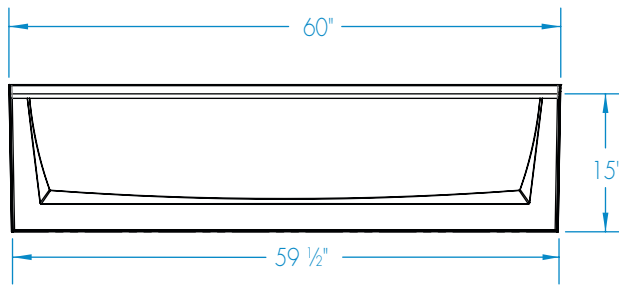
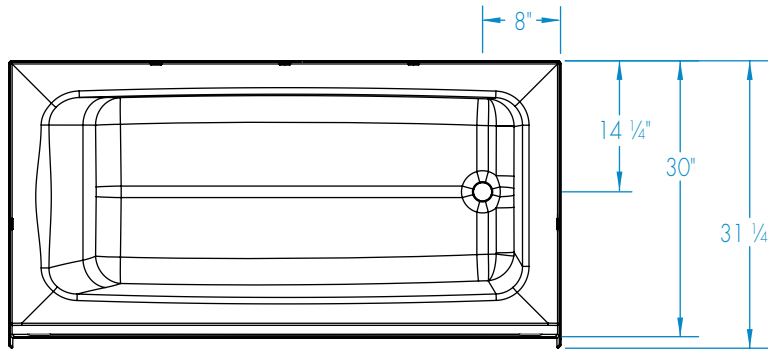

FEATURES lbs Dimensional Tolerance $\pm 3/16"$. Dimensions needed for site preparation should be measured from the unit. Aquatic assumes no responsibility for preparatory work.

Model #	Material	Jets	Motor	Controls	Drain	Net Wt.	Pkg. Wt.
Soaker #6030CT	Composite	-	-	-	LH or RH	54	59

DIMENSIONS

Specifications	inches
Width: Overall / Net	60
Depth: Overall / Net	31 1/4 / 30
Height: Overall / Net	16 1/2 / 15
Enclosure Opening	-
Skirt Height	15
Drain Rough-In (from Back Wall)	14 1/4
Drain Rough-In (from Side Wall)	2 7/8
Drain: Diameter / Clearance	2 / 1/2

FRAMING DIMENSIONS

 inches

Type	D Depth	W Width	H Height	A	B	C
Alcove	31 1/4	60	16	Box Out	2 7/8	14 1/4

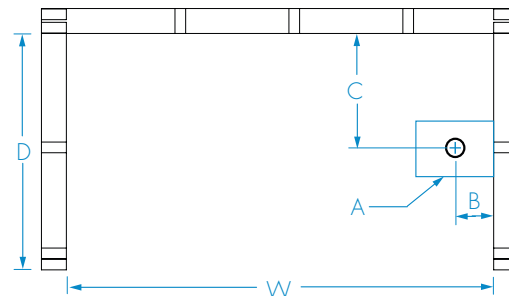

SUMP DATA

Top of Drain to Bottom of Overflow	Capacity to Overflow gal	Min. Operating Capacity gal	WIDTH @ centerline		DEPTH @ centerline	
			Top	Bottom	Top	Bottom
9 7/8	37	-	51 1/2	45 1/2	22 1/4	20 1/2