



Series **36**  
**Combination Air Valves**  
 (Single Body Type)

**INTRODUCTION**

This manual will provide you with the information to properly install and maintain this valve to ensure a long service life. The valve has been designed with stainless steel trim to give years of trouble-free operation. The Combination Air Valve is typically mounted at the high points in a piping system and performs the functions of both an air release valve and air/vacuum valve.

The Combination Air Valve automatically vents air which accumulates at high points in a system during its operation. The valve will also exhaust and admit large quantities (volumes) of air during filling or draining operations and after emergency conditions such as a power failure. Both the air release and air/vacuum functions are needed to maintain pipeline efficiency while providing protection from adverse pressure conditions.

The valve is a float-operated, resilient-seated valve designed to handle fluids having minimal suspended solids. The Maximum Working Pressure and Model No. are stamped on the nameplate for reference.

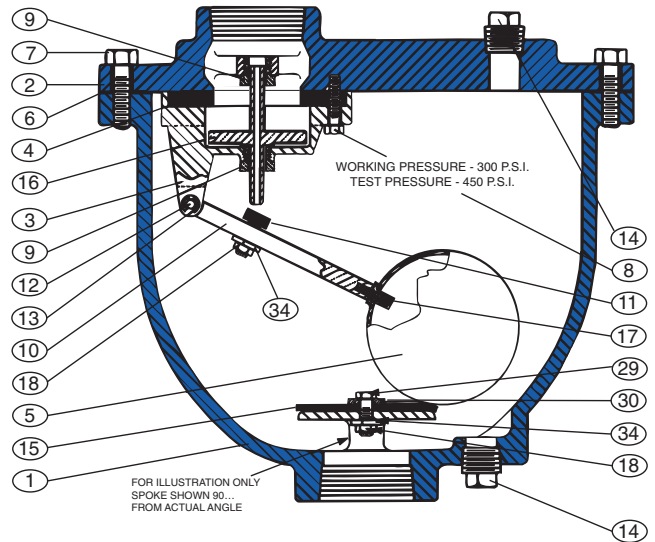

Figure 1. Custom Combination Air Valve

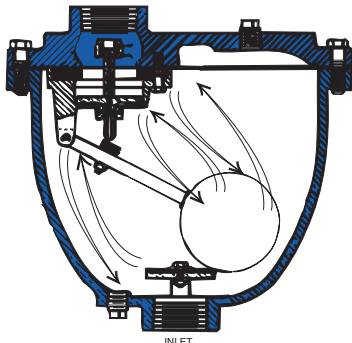

Figure 2. Air Exhausted and Air Intake During Pipeline Fill and Drain.

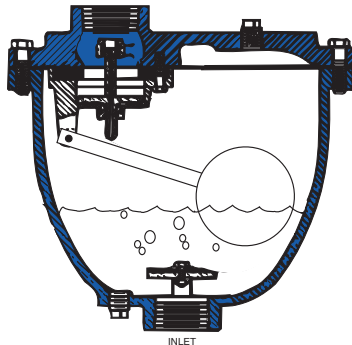

Figure 3. Accumulated Air Continuously Released

Sizes 1" - 4" Threaded Inlet

**RECEIVING AND STORAGE**

Inspect valves upon receipt for damage in shipment. Handle all valves carefully without dropping. Valves should remain boxed, clean and dry until installed to prevent weather related damage. For long term storage greater than six months, the valves must remain in the box and stored indoors. Do not expose valves to sunlight or ozone for any extended periods.

**DESCRIPTION OF OPERATION**

The Combination Air Valve is fully automatic and designed to continuously remove air accumulating at high points in a piping system. It also will exhaust and admit air during filling and draining of the pipeline or tank. The valve, as shipped, is a normally open valve and has three functions.

Detail No.	Part Name
1	Body
2	Cover
3	Baffle
4	Seat
5	Float
6	Gasket
7	Cover Bolt
8	Retaining Screw
9	Guide Bushing
10	Float Arm
11	Orifice Button
12	Pivot Pin
13	Retaining Ring
14	Pipe Plug
15	Cushion
16	Plug
17	Float Retainer
18	Lock Nut
29	Cushion Retainer
30	Washer (internal)
34	Washer (external)

1. During System start-up, the open valve will exhaust large quantities of air until fluid enters the valve. The float will then rise and press the orifice button located in the float arm, against the plug stem and raise the plug. Pressure within the valve body will force the plug upward tightly against the seat. When system is drained the plug will open allowing air to reenter the system.
2. As air accumulates in the piping system and enters the valve, the float drops and the orifice button breaks contact with the plug stem. Accumulated air will vent through the plug stem. As the air is vented, the float raises once again and closes the plug stem orifice. See Figure 2.

- When the system is drained, the plug will reopen allowing air to rapidly re-enter the piping system. See Figure 2.

### INSTALLATION

The installation of the valve is important for its proper operation. Valves must be installed at the system high points in the vertical position with the inlet down. For pipeline service, a vault with freeze protection, adequate screened venting, and drainage should be provided. During closure, some fluid discharge will occur so vent lines should be extended to an open drain area in plant services. A shut-off valve should be installed below the valve in the event servicing is required.

**CAUTION:** Always Install valve with "INLET" port down or flooding will occur.

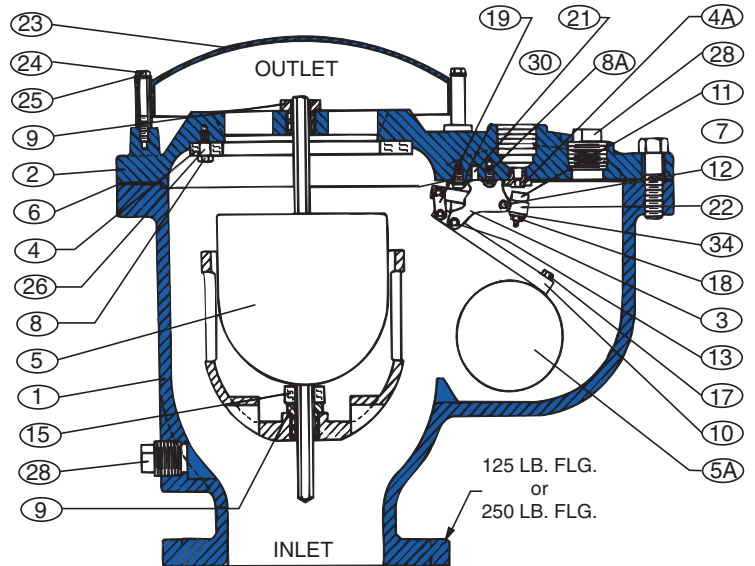

Sizes 6" & 8" Flanged Parts List

Detail No.	Part Name
1	Body
2	Cover
3	Leverage Frame
4	Seat
4a	Seat
5	Float
5a	Float
6	Gasket
7	Cover Bolt
8	Retaining Screw
8a	Retaining Screw
9	Guide Bushing
10	Float Arm
11	Orifice Button

Detail No.	Part Name
12	Pivot Pin
13	Retaining Ring
15	Cushion
17	Float Retainer
18	Lock Nut
19	Link
21	Locating Pin
22	Orifice Button Arm
23	Hood
24	Hood Retaining Screw
25	Washer - External
26	Seat Retaining Sleeve
28	Pipe Plug
30	Washer
34	Lock Washer

### MAINTENANCE

The Combination Air Valve requires no scheduled lubrication or maintenance.

**INSPECTION:** Periodic inspection to verify operation can be performed. A manual drain valve can be installed in the lower drain plug to plug to perform this operation as shown in Figure 7.

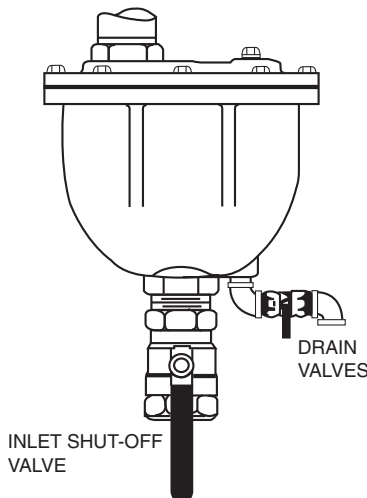

FIGURE 5. INSPECTION PIPING

- With the inlet shut-off valve open, partially open the drain valve until flow can be heard. If the air valve is working properly, water should be exhausted from the drain valve. If air is exhausted, follow steps 2-6.
- Close the inlet shut-off valve.
- Slowly open the drain valve to allow the fluid in the valve to drain. If draining is difficult, the valve may be clogged (valve requires service).
- Close the drain valve
- Slowly open the inlet shut-off valve to fill the valve with water. Observe the seating action and verify that the valve closes without leakage.
- If leakage occurs, the valve should be removed and inspected for water or possible damage from foreign matter.

## TROUBLESHOOTING

Several problems and solutions are presented below to assist you in troubleshooting the valve assembly in efficient manner

### Leakage at Bottom Connection:

Tighten valve threaded connection. If leaks persist, remove valve and seals threads with pipe sealant or tape.

### Leakage at Cover:

Tighten bolts per Table 2, replace gasket.

### Valve Leaks when Closed:

Flush valve to remove debris. Disassemble and inspect seat, orifice button and float. NOTE: Many floats contain sand for weight but if water is detected replace float.

### Valve not venting Air:

Check that operating pressure does not exceed Working Pressure on nameplate. Perform inspection steps 2-6 and disassemble valve if problem persists.

## DISASSEMBLY

The valve can be disassembled without removing it from the pipeline. Or for convenience, the valve can be removed from the line. All work on the valve should be performed by a skilled mechanic with proper tools. No special tools are required.

**CAUTION:** The valve must be drained before removing the cover or pressure may be released causing injury.

1. Close inlet shut-off valve. Slowly open drain valve or remove drain plug. Remove the covers bolts (7) on the top cover.
2. Pry cover (2) loose and lift off valve body.
3. Remove the retainer ring (13) and pivot pin (12) that pass through the float arm (10).
4. To remove baffle (3), remove fasteners (8).
5. Remove lock nut (18) and orifice button (11).
6. Clean and inspect parts. Note: some floats contain sand for extra weight; if water is detected, replace float. Replace worn parts as necessary and lubricate parts with FDA grease such as Lubriko #Cw-606. Remove all foreign matter from body and cover.

## REASSEMBLY

All parts must be cleaned and gaskets surfaces should be cleaned with a stiff wire brush in the direction of the serration or machine marks. Worn parts, gaskets and seal should be replaced during reassembly. Refer to Figure 6.

1. Apply Loctite Primer and 680 Compound to float threads and assemble to arm (10). Apply Loctite to bushing (9) and install into baffle (3).
2. Lay cover on flat surface with outlet faced down. Lay seat (4), plug (16), and baffle (3) over cover with screws (8) loosely engaged. Verify that plug moves up and down freely. Lift plug and drop into seat until baffle is positioned and plug contacts seat smoothly; tighten screws to 5-10 ft. lbs.
3. Screw new orifice button (11) into arm (10) with lock washer (34) and lock nut (18). Do not tighten nut at this time.

4. Connect arm (10) to baffle (3) with pivot pin (12) and retaining rings (13).
5. Adjust orifice button so that when it is in light contact with the plug stem, the arm (10) slopes away from the cover about 1/15". Lock orifice button with lock nut (18).
6. Install new cushion (15) with fastener items (29, 30, 34, & 18).
7. Lay new cover gasket on clean surface and apply a gasket compound such as Permatex #80065 to both surfaces. Assemble gasket (6) and cover (2) over bolt holes in body (1).
8. Insert lubricated bolts (7) and tighten to the torques listed in Table 2.
9. Place valve back in service. Slowly open inlet isolation valve.

<u>BOLT SIZE</u>	<u>TORQUE (FT. LBS.)</u>
7/16"-14	30
1/2"-13	45
5/8"-11	93
3/4"-10	150
7/8"-9	200

TABLE 2. VALVE COVER BOLT TORQUES

## PARTS AND SERVICE

Parts and service are available from your local representative or the factory. Make note of the valve Model No. and Working Pressure located on the valve nameplate.

