

LIST OF MATERIAL

| NO. | DESCRIPTION        | MATERIAL | PART   | QTY. |
|-----|--------------------|----------|--------|------|
| 1   | SCREW              | BRASS    | 92865  | 1    |
| 2   | WING NUT           | BRASS    | 51039  | 1    |
| 3   | STRAINER           | BRASS    | 51015  | 1    |
| 4   | GASKET             | BRASS    | 51016  | 1    |
| 5   | NUT                | SS304    | 51017  | 1    |
| 6   | SPINDLE            | BRASS    | 51019  | 1    |
| 7   | BODY ASM, WING NUT | -        | 20-303 | 1    |
| 8   | MTG HDWR KIT       | -        | 5-063  | 1    |

1 APPLY LOCTITE 680 OR EQUIVALENT

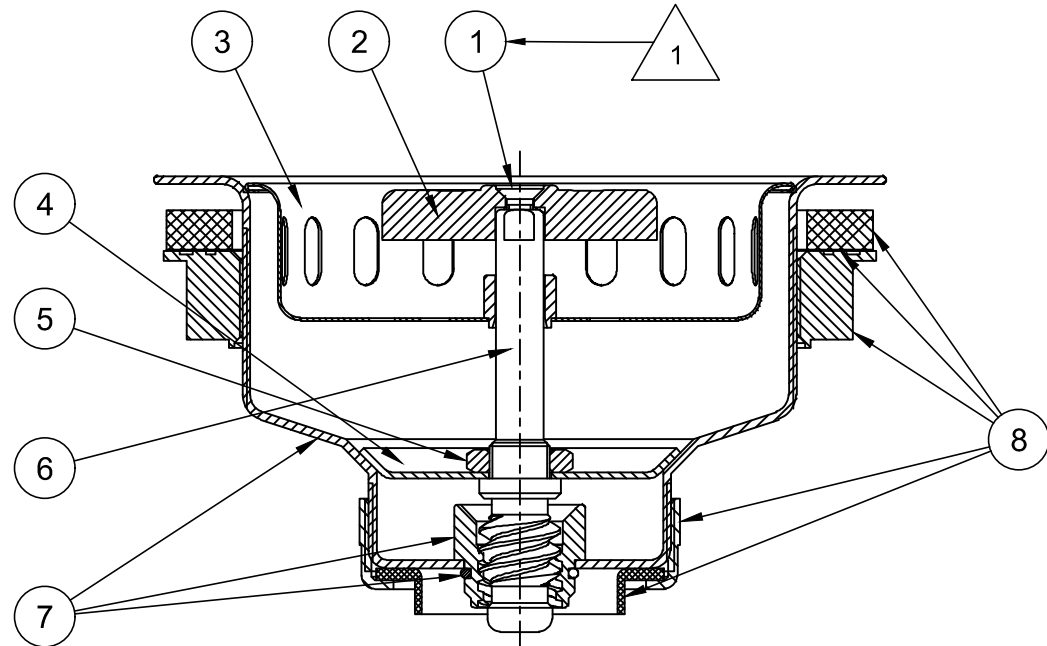
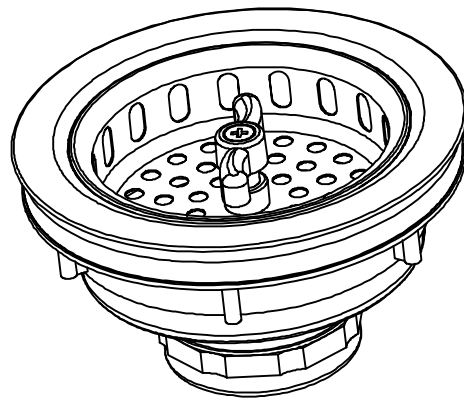

LARGE BASKET STRAINER, WING NUT LOCKING STYLE

EN-3401



DWG NO. **#120**  
 SHEET 1 OF 1  
 SCALE 1:1

REV. C  
 TOLERANCES (INCH) :  
 .X ± 0.04  
 .XX ± 0.03  
 .XXX ± 0.02  
 ANGLES ±1.5°

UNITS: INCH[mm]  
 FACTORY: Zhejiang

MATERIAL: -  
 WEIGHT(g): -  
 NEXT ASSY: -  
 USED ON: -

|     |              |           |          |
|-----|--------------|-----------|----------|
| C   | NEW BOM      | SEP/20/17 | BAU      |
| B   | NEW ITEM NO. | JUL/31/17 | BAU      |
| REV | DESCRIPTION  | DATE      | APPROVED |