

NOTES:

1. FIT / FORM / FUNCTION SHALL FOLLOW PS-E.008.

BILL OF MATERIAL (CURRENT LEVEL)

| ITEM | PT/ASSY | DESCRIPTION | TYPE | QTY. |
|------|---------|--------------------------|----------|------|
| 1 | 2-817 | SOAP DISPENSER BODY ASM | ASSEMBLY | 1 |
| 2 | 125-6 | SOAP DISPENSER PUMP HEAD | ASSEMBLY | 1 |
| 3 | 125-9 | SOAP DISPENSER BOTTLE | PART | 1 |

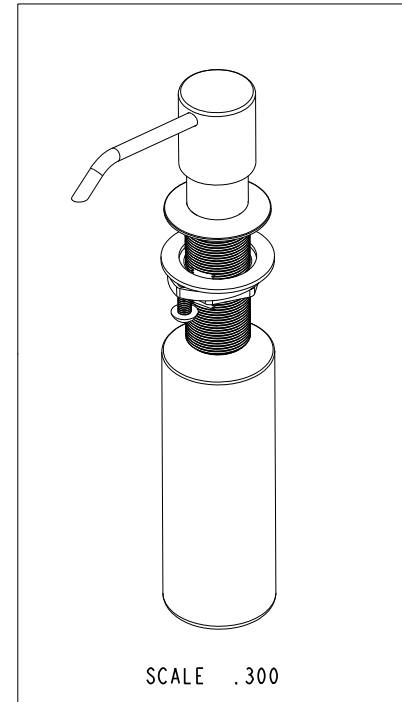
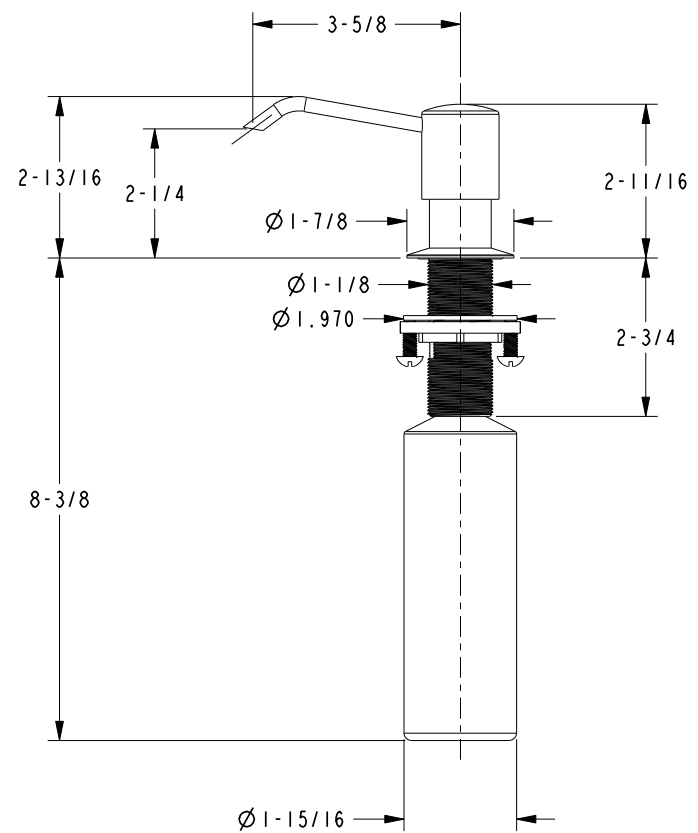
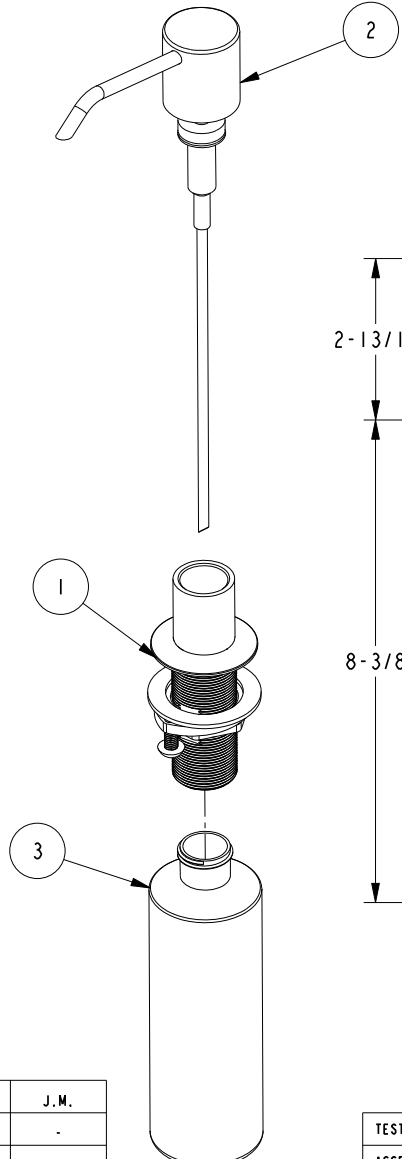

| - | E | EN-3763 | 11/30/18 | J.M. |
|------|-----|-------------|----------|----------|
| - | D | EN-2033 | 02/15/12 | - |
| - | C | EN-1751 | 05/11/11 | - |
| - | B | EN-1201 | 10/07/09 | - |
| - | A | EO-0529 | 07/05/05 | - |
| - | - | RELEASED | PRE 95' | - |
| ZONE | REV | DESCRIPTION | DATE | APPROVED |

COPYRIGHT 2005 BRASSTECH, INC. THESE DRAWINGS AND THE DESIGNS DEPICTED HEREIN ARE THE PROPRIETARY PROPERTY OF BRASSTECH. ANY USE OR REPRODUCTION IS SUBJECT TO THE EXPRESS APPROVAL OF BRASSTECH. UNAUTHORIZED USE IS STRICTLY PROHIBITED. ALL RIGHTS RESERVED.

| | | | |
|-----------|-----------|----------------------------------|---------|
| TESTING | - | - | - |
| ASSEMBLY | - | - | - |
| PLATING | - | - | - |
| POLISHING | - | NEXT ASSY | USED ON |
| MACHINING | - | APPLICATION | |
| TOOLING | FIXTURE # | REMOVE ALL BURRS AND SHARP EDGES | |

| | |
|---|----------------------|
| UNITS ARE: INCHES [MM] | |
| TOLERANCES ARE: | |
| FRACTIONS | DECIMALS |
| ±1/16" | ±.005 |
| .X ±.1 [2.5] | ±1° |
| .XX ±.06 [1.5] | |
| (X.XXX) DENOTES CRITICAL DIMS. ALL THREADS ARE CRITICAL | |
| DRAWN | ANDY NGUYEN 02/16/12 |
| CHECKED | - 02/16/12 |
| APPROVED | - 02/16/12 |

BRASSTECH 2001 CARNEGIE AVE. SANTA ANA, CA 92705 (949) 417-5207
INCORPORATED

SOAP/LOTION DISPENSER

DWG NO. **125** REV **E**

SCALE **.300** REF. - SHEET **1** OF **1**