

NOTES:

(NI) 1. TO INSPECT ASSEMBLY, FOLLOW FIRST ARTICLE AND IN PROCESS INSPECTION SHEET.

BILL OF MATERIAL (CURRENT LEVEL)

ITEM	PT/ASSY	DESCRIPTION	TYPE	QTY.
1	6-412	S.V. 1/2" CU X 3/8" CMP	ASSEMBLY	1
2	50355	HANDLE	PART	1
3	92073	SCREW #0 X 3/8" PHIL OVAL HD BRASS	PART	1

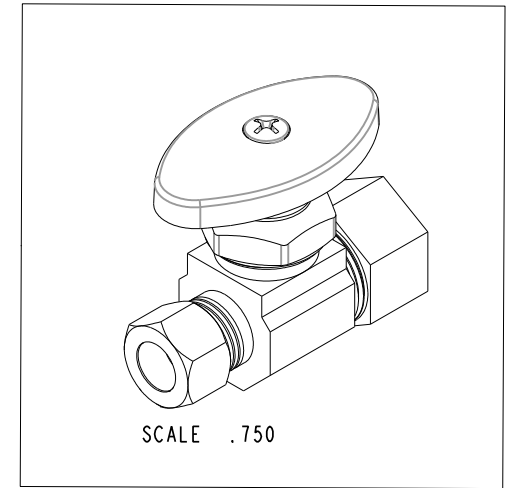
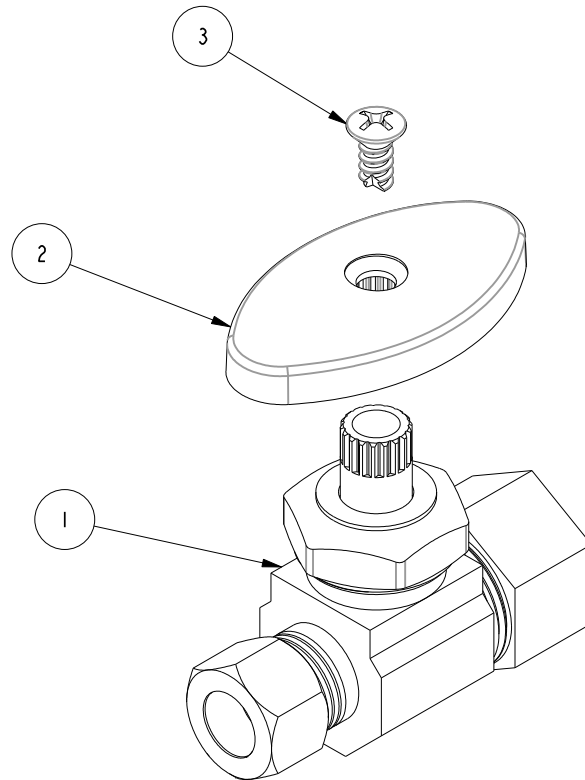

TESTING	-	-	-
ASSEMBLY	-	-	-
PLATING	-	-	-
POLISHING	-	NEXT ASSY	USED ON
MACHINING	-	APPLICATION	
TOOLING FIXTURE #		REMOVE ALL BURRS AND SHARP EDGES	

**BRASSTECH** 2001 CARNEGIE AVE.  
INCORPORATED SANTA ANA, CA 92705  
(949) 417-5207

**STRAIGHT VALVE 1/2" CU X 3/8" CMP**

DWG NO. **412** REV **A**

SCALE 1.000 REF. - SHEET 1 OF 2

COPYRIGHT 2005 BRASSTECH, INC. THESE DRAWINGS AND THE DESIGNS DEPICTED HEREIN ARE THE PROPRIETARY PROPERTY OF BRASSTECH. ANY USE OR REPRODUCTION IS SUBJECT TO THE EXPRESS APPROVAL OF BRASSTECH. UNAUTHORIZED USE IS STRICTLY PROHIBITED. ALL RIGHTS RESERVED.

ZONE	REV	DESCRIPTION	DATE	APPROVED
-	A	EN-4407	10/11/21	N.S.
-	-	EN-2537	05/17/13	J.M.

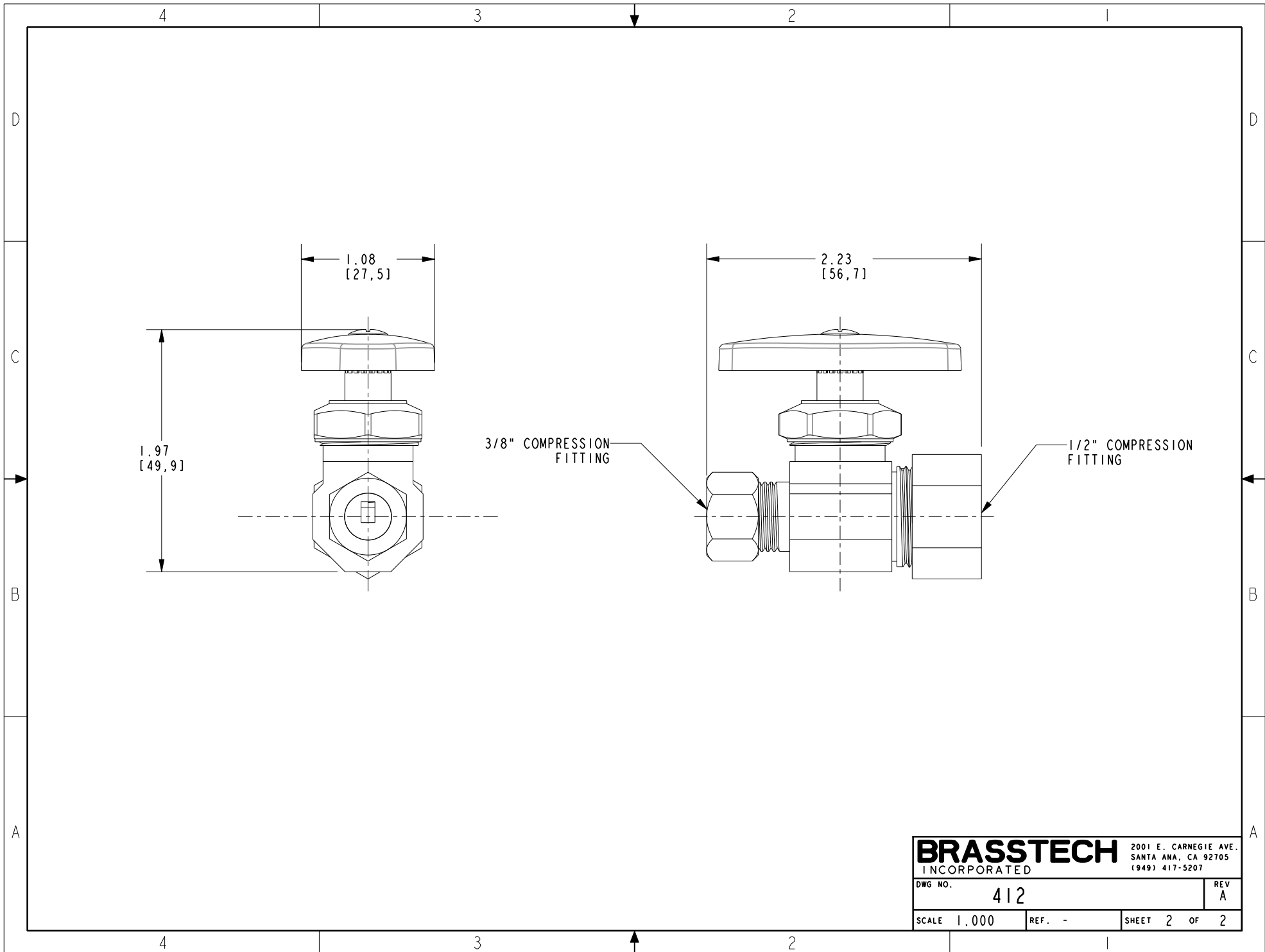

<b>BRASSTECH</b>		2001 E. CARNEGIE AVE.	
INCORPORATED		SANTA ANA, CA 92705	
DWG NO. 412		REV A	
SCALE 1.000	REF. -	SHEET 2 OF 2	