

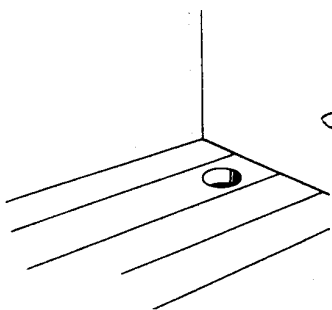

***It's easy
to install
Slant/Fin
baseboard.***

Here's how...

highlights of quick, easy



1. Drill holes for risers and connecting piping.

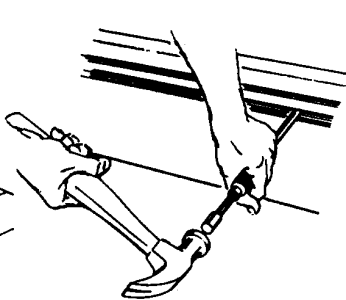

2. Nail baseboard to wall. For faster installation, use "T-Shot" Nailing Tool, or, use power screw gun.

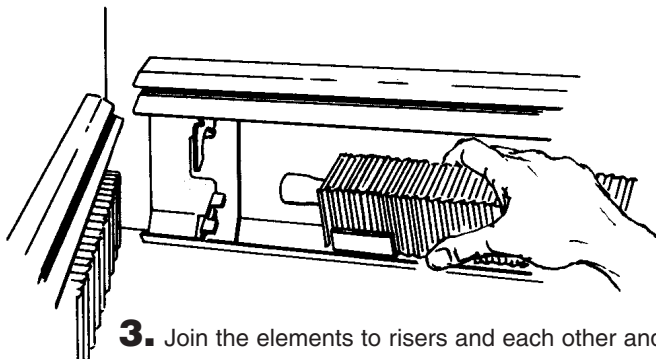
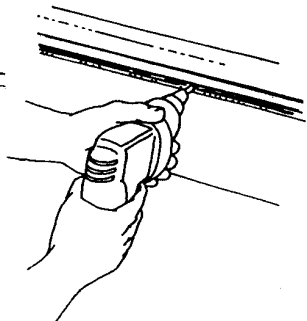

3. Join the elements to risers and each other and rest on brackets.

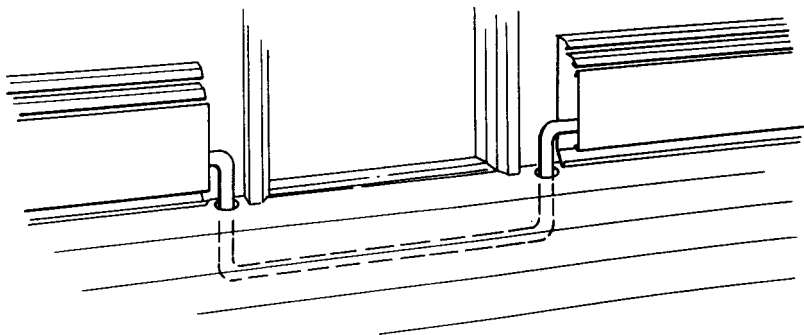

4. Drop piping under doorways.

Slant/Fin installation

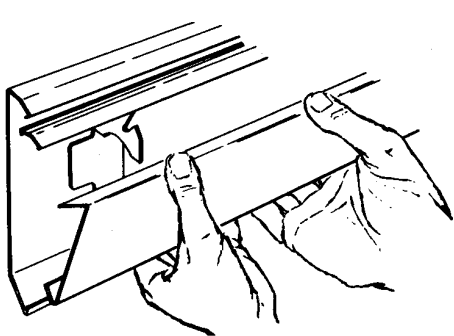

5. Snap front panel back in place.

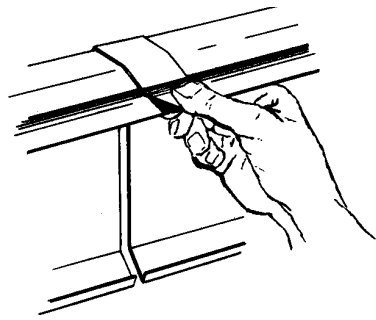

6. Join baseboard lengths with splice plates.

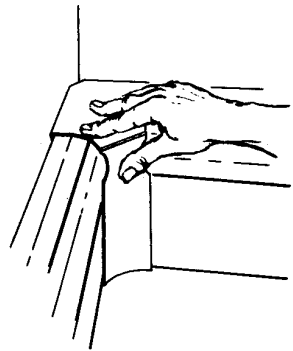

7. Snap on inside corners and outside corners.

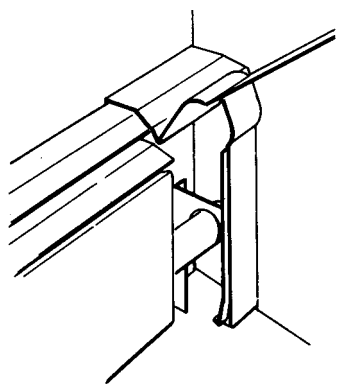
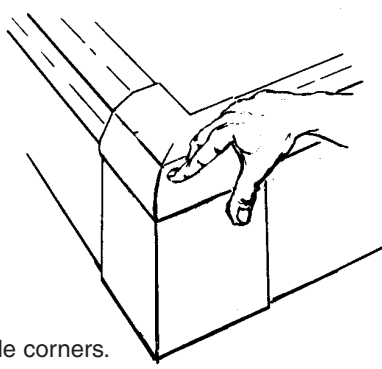

8. Install wall trims at partitions.

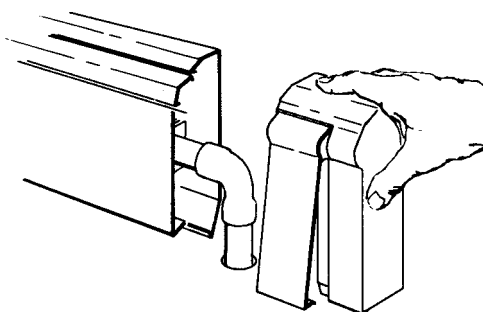

9. Slide on end caps for finishing touch.

Slant/Fin[®]

easiest kind of heating to install (and the most beautiful)

You'll find that pre-assembled Slant/Fin baseboard is surprisingly easy to handle. With Slant/Fin pre-cut lengths and telescoping accessories you can leave your hacksaw at home. All parts snap together securely at the touch of your fingers, and they stay together. You end up with a neat, wall-to-wall installation of beautiful and efficient baseboard heating, without a shortened temper or bleeding hands. And you're in and out in half the time you'd need with most other baseboards.

what the parts are called...

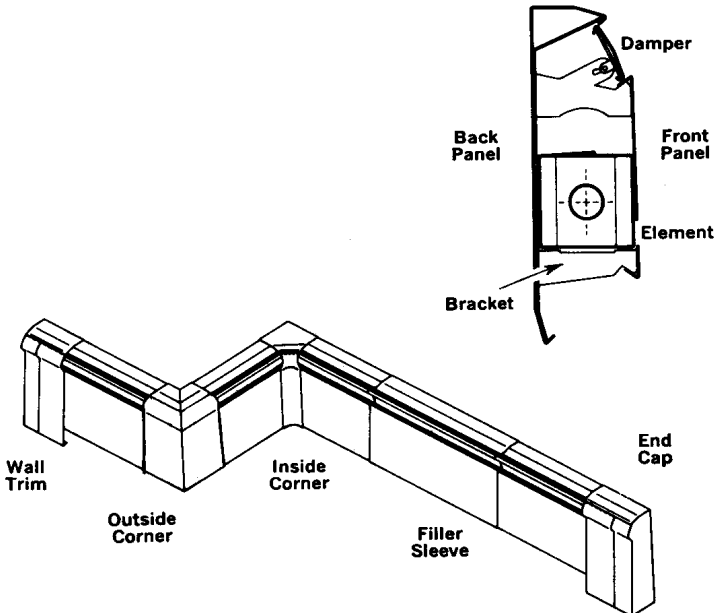

Baseboard and all accessories serve both flush or recessed installation.

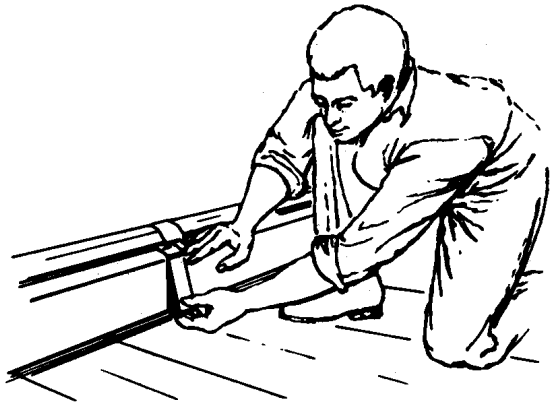

variety of stock lengths and adjustable accessories assure neat fit without cutting...

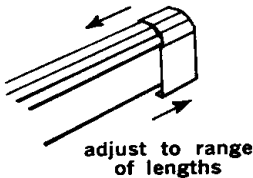

Slant/Fin baseboard units come in a wide variety of standard lengths. The Slant/Fin accessories simply snap over and behind the baseboard units permitting them to slide left or right. The amount of overlap can be adjusted from only 1/2" to almost the full width of the accessory. This way you can virtually "stretch" or compress standard lengths of baseboard and accessories to fit any length of wall without cutting them. Slant/Fin installs faster than any other baseboard in the world.

LENGTH NEEDED: (Simply determine which combination satisfies requirements).

These stock lengths are available in both the complete baseboard package and enclosure only (the unit without heating element, sometimes referred to as dummy cover).

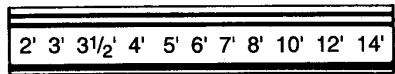

S/F accessories adjust telescopically to these lengths:



End Cap
1/2" - 3 1/2"



Inside Corner
2 1/4" - 3 1/4"



7" Filler Sleeve
1/2" - 6"



Valve Cover
1/2" - 7 1/2"



Wall Trim
1/2" - 3 1/2"



Outside Corner
0" - 1"

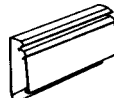

14" Filler Sleeve
1/2" - 13"



2" Splice Plate
0" - 1"
(Free with every unit
5 feet and over)

plan your piping...

Here are examples of **three** basic piping systems, shown with and without options for zoning.

1. SERIES LOOP

Series loop--single zone

(The simplest, most economical system to install.) The Slant/Fin baseboard damper provides individual room control. A single circuit runs from the boiler to the first run of baseboard, continues from there to the next room and so on. The last baseboard unit in the series is connected to the return at the boiler. It keeps pipe, fittings, controls and labor costs to a minimum. Use separate loop for each zone.

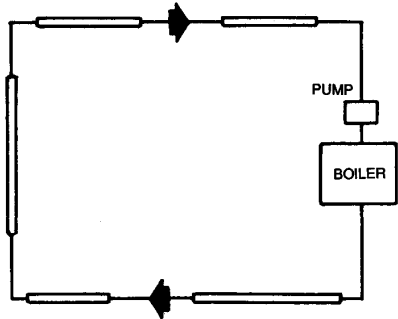

Series loop--single zone

Series loop--multiple zones

Each zone is a "Series loop" with any number of Slant/Fin baseboard units and controlled by its own room thermostat.

In the *zone valve* arrangement, each zone has an electrically operated zone valve and there is a single pump for the whole system.

In the *zone pump* arrangement, each zone is provided with a pump, a flow control valve and a relay.

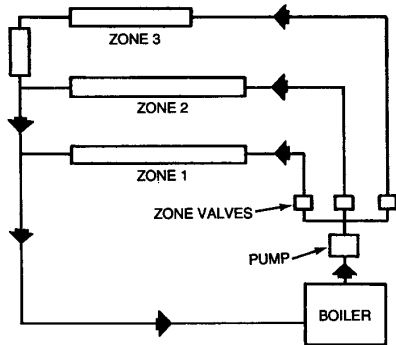

Series loop--multi-zone with zone valves

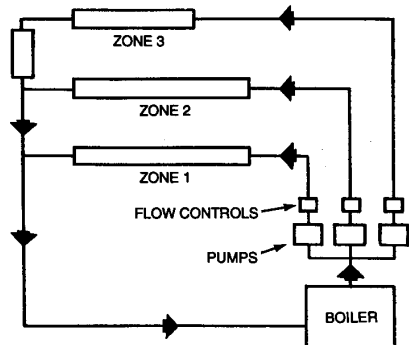

Series loop--multi-zone with individual pumps

2. SPLIT LOOP Provides more even heat distribution and the option of separate zone control. The house is "divided" into two (or more) sections, each with its own circuit. Each circuit draws water of the same temperature from a central trunk line. Balancing valves should be installed in each circuit at return end just before entering circulator.

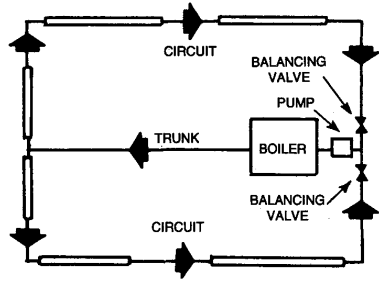

3. ONE PIPE WITH DIVERTER TEES Permits individual room shut-off or thermostatic control. Each baseboard unit is connected to the main by a supply and return branch connection (usually with a shut-off valve at the diverter tee). This offers a sophisticated system of room temperature control, particularly in conjunction with Slant/Fin's fully modulating damper.

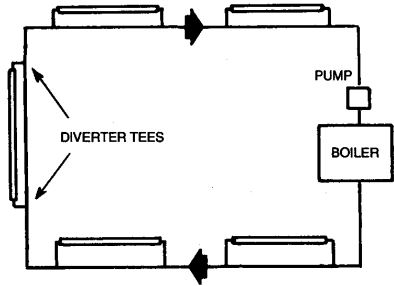

air elimination...

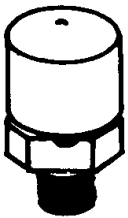

Provision must be made for venting air from system, to prevent noise or blockage of circulation by air pockets. Either install a manual air vent at every drop, or install an automatic air eliminator device at the boiler and a vent at highest point of the system for extra safety. A vent at every drop is an advantage in case the system is later drained and refilled without purging.



figure out what material to order...

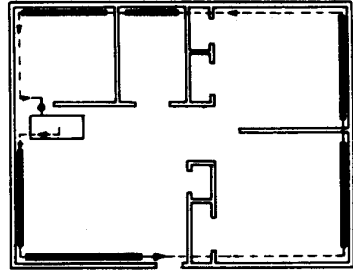

*Solid line indicates baseboard.
Broken line indicates piping below
floor, or in "enclosure only".*

First take wall to wall measurements of all rooms from the plan or by actual field measurement. Next, calculate the heat loss for each room, using the IBR or equivalent method. Then translate the output required into the list of materials needed for each room and wall.

NOTE: Often a shorter-than-wall length of radiation is called for. For instance, only 8 feet of radiation may be required on a 12 foot wall. You can drop the pipe through the floor after 8' (Method A) or continue the run to the far wall for an attractive wall-to-wall look, using enclosure only with plain tubing inside (Method B). Although this uses more material, it's often the simplest way to do the job. At the far wall you can drop the pipe through the floor or run it through the wall to the next room. Straight through eliminates potential air problems. (See page 15 for tips on installing enclosure only.)

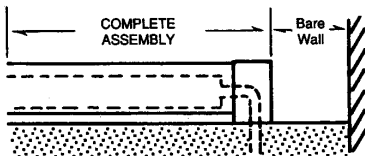

*Method A: pipe drops through the
floor at end of "complete assembly"
baseboard.*

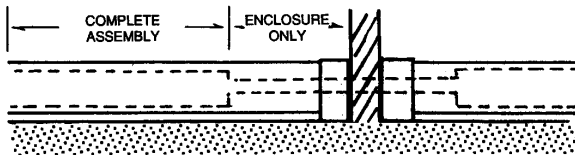

*Method B: bare
pipe runs to far wall
inside "enclosure
only".*

Make out a schedule of the material you need, room by room, so when you get it you can sort it out easily for quick installation. Then place your order.

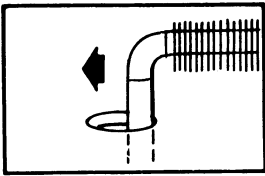
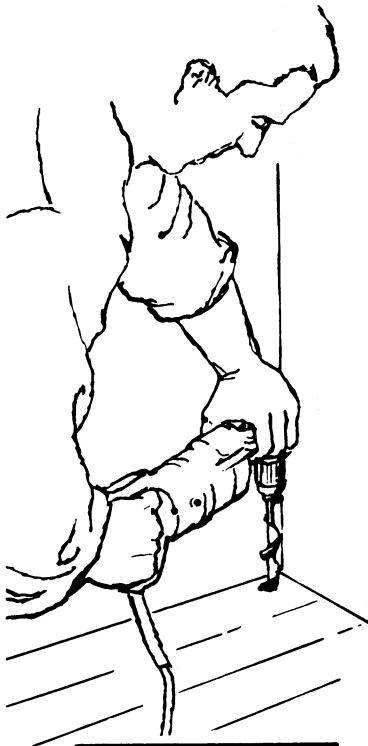

begin by drilling riser holes...

The riser connects sub-floor supply tubing to the baseboard. The diameter of the riser hole and the location of the hole with respect to the walls will vary depending on the type of baseboard you're using. Here is a handy chart to follow:



Model	Diameter		Back Wall to Center (floor holes)	Floor to Center (partition holes)
	Pipe	Hole*		
BL-50/75	1/2" or 3/4"	1 1/4"	1 3/8"	2 5/16"
15-50	1/2"	1"	1 21/64"	3"
15-75	3/4"	1 1/4"	1 21/64"	3"
30-75	3/4"	1 1/4"	1 3/8"	3 3/16"
81A	3/4"	1 1/4"	1 3/4"	3 7/8"
83A2	3/4"	1 1/4"	1 9/16"	3 1/2"
84A3	1"	1 1/2"	1 9/16"	3 1/2"
85A/86AX	1 1/4"	1 3/4"	1 3/4"	3 7/8"

* Hole is 1/2" larger than pipe to allow for expansion. Install riser snug to inside edge of hole to allow maximum room for riser to move to outside edge of hole when pipe expands.

distribute the cartons along the walls...

To make installation easy, lay out the cartons of material and accessories along the wall in the order in which they will be installed. Pre-planning should specify which combination of baseboard and accessories fits best.

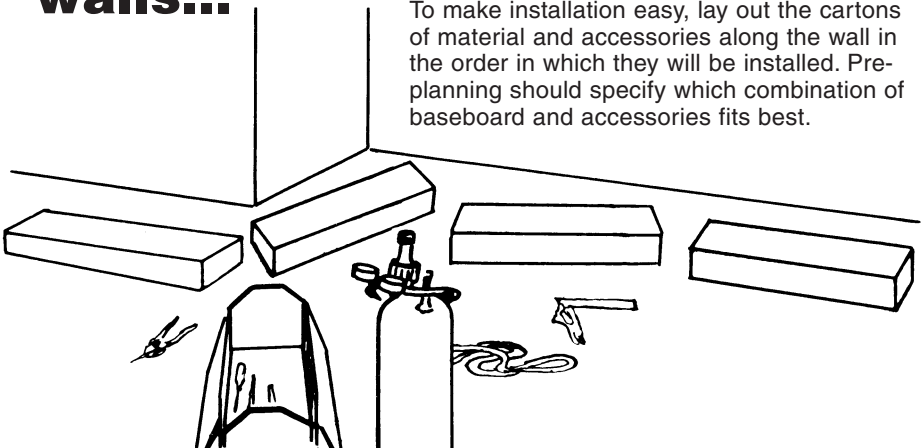

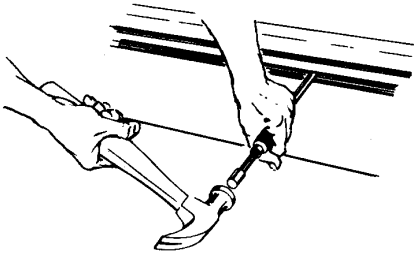

nail it up...

The pre-assembled baseboard goes right from carton to wall with Slant/Fin's "T-Shot" Nailing Tool (or power screw gun). You can load the Nailing Tool with any nail up to $\frac{5}{16}$ " round head. Just place the baseboard against the wall, and slip the Nailing Tool between the damper and front panel. Hit the drive rod with the hammer and that's it. Add another row of nails below the front panel. If you're working without a "T-Shot" or screw gun, snap off the front panel by lifting it upward so the bottom bracket bends slightly upward, then pull toward you with thumb.

1. for plaster walls...

Locate the studs in the wall and mark location above baseboard, or on floor. It's best to nail the baseboard at top and bottom to each stud.

2. for concrete or cinder block walls...

Use masonry nails, or install a furring strip and nail into it.

3. for a particularly solid installation...

Slide the bracket to the stud position and drive nail through the bracket holes and the back panel.

before you drive your nails...

Make sure you leave enough room at the ends of the baseboard or other points where accessories will have to be installed later.

NOTE: To avoid scratching or cutting yourself, always handle baseboard with care.

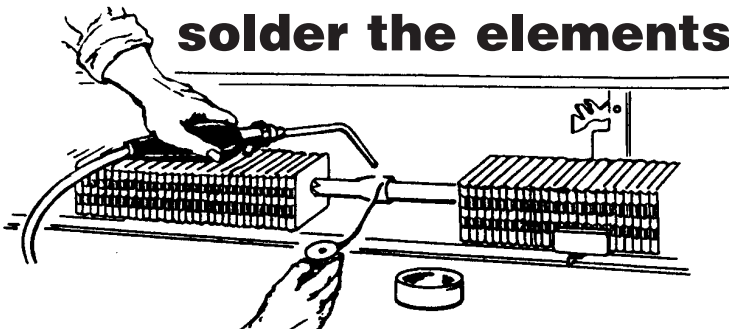

solder the elements...

1. Clean and solder the adjoining element ends together using a non-corrosive flux, and connect elements to risers.
2. Immediately upon completion, flush system thoroughly. Left unflushed, flux can cause pitting in copper tubing of unfilled systems.
3. Fill system as soon as possible but prevent from freezing.
4. Make sure cradles are centered over brackets to allow for smooth expansion without scraping noises.

Provide for expansion with HYDRO/TITE expansion couplings on long straight runs.

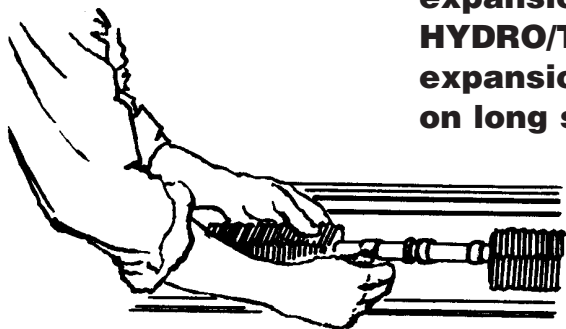

All piping expands when heated. In shorter runs, the movement of the risers in their holes will take care of expansion. But on longer runs, it's wise to install an expansion compensator to prevent strains at the joints and buckling of the elements. Install a Hydro/Tite at the center of a long run.

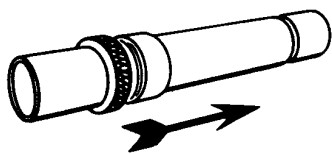

FLOW DIRECTION must be as shown, to keep sludge from clogging the seals inside the Hydro/Tite.

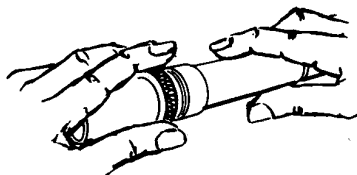

DON'T LOOSEN or tighten the knurled collar. Proper adjustment (set at factory) is hand-tight only.

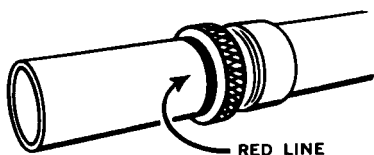

PULL OPEN until red line just shows under the knurled collar. Install in this extended position.

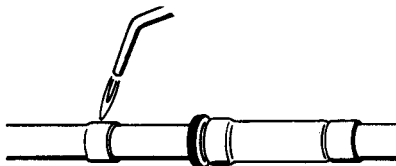

KEEP HEAT AWAY from the knurled collar and the coupling body, to avoid damage. Use soft solder only.

replace front cover...

BASELINE 2000, FINE/LINE 30 & MULTI/PAK 80

Place lower edge underneath lower bracket.
Lift slightly and press upper edge forward
with thumb till panel snaps into place.



FINE/LINE 15

Place top edge of front panel on bracket
with panel in "up" position, swing down.
Important: to lock the panel to the bracket,
pull cover outward away from bracket,
while swinging down. Push bottom of
panel to engage lower bracket.

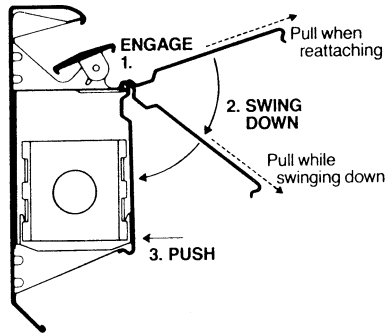

snap on the accessories...

WALL TRIMS, END CAPS, CORNERS

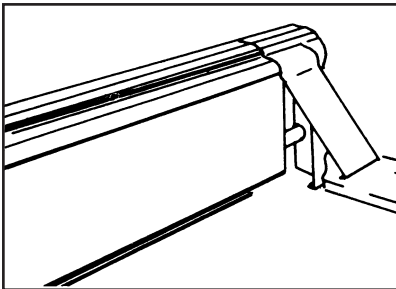

For a neat finish at partitions, use the wall trim (adjustable up to 3 1/2"). Air vents are recommended at each drop; either wall trim or end caps (both hinged) provide easy access to vent. These accessories eliminate the wasteful need for cutting large baseboard units to fit small gaps, and save you time and effort. Attractive inside and outside corners assure a custom look.

FILLER SLEEVE, SPLICE PLATES

The Filler Sleeve has 4 parts: back piece, damper sleeve, top sleeve, front sleeve. The Splice Plate is exactly the same, but without a back piece.

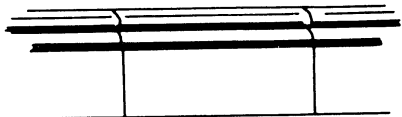

FILLER SLEEVES (cont'd)

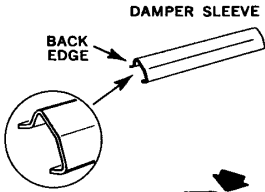
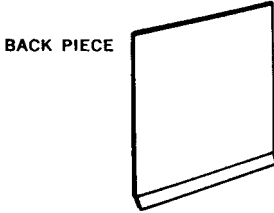

1. When mounting the baseboard to the wall, be sure the filler sleeve will overlap each baseboard unit by at least $\frac{1}{2}$ ".
2. Slip in the back piece so that the bent edge rests in the bottom channel of the baseboard. Nail the back piece to the wall to hold it in place.
3. Move both dampers to half-open position. Hold the damper sleeve with the crimped edge away from you. Hook its front edge over the front edges of the dampers. Snap the back edge of the sleeve into place by pinching -- with thumb pressure on the baseboard top panel and finger pressure up under the back edge of the damper.

- 3A. (For Multi/Pak 80) Move both dampers to half open position. Hook the damper sleeve's top edge over the top edge of the dampers. Press down on the sleeve and snap the bottom edge into place.

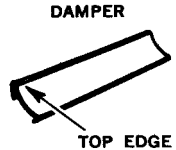

4. Hook the sharp angle of the top sleeve over the front edge of the baseboard's top panel. Press down on the back edge until the sleeve snaps into place.
5. Replace baseboard front covers. Hook the front sleeve's top edge over the front covers and snap the bottom edge into place.

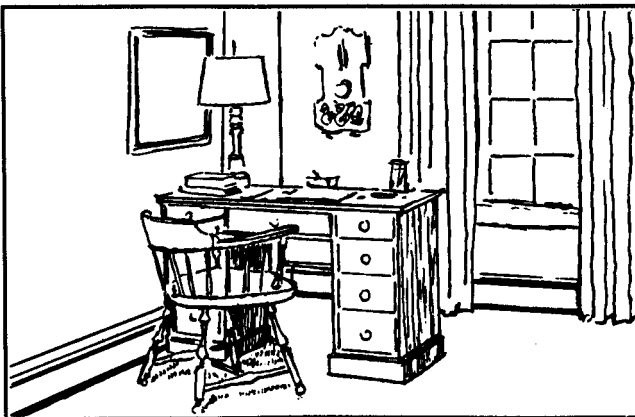

fine points, for a perfect job

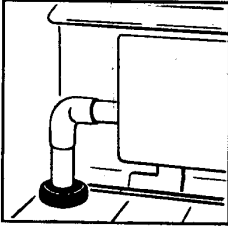

RISER-RINGS slip around tubing where it passes through flooring. They provide neat, clean, sanitary seal and absorb expansion squeaks and vibration noises. May be installed after connections are made.

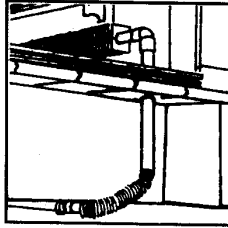

FAST/FLEX CONNECTORS can be hand-formed to fit varied piping problems. Use them to fit around obstructions, compensate for misalignment, soak up vibration and expansion at turns, eliminate many solder joints. Cannot be used as an expansion compensator.

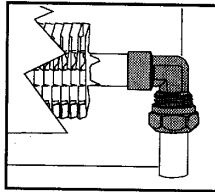
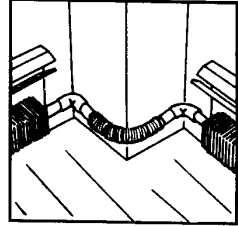

PEX-TO-BASEBOARD CONNECTOR When PEX tubing is used to and from the boiler, Slant/Fin Terra Therma PEX adapters connect tubing to copper baseboard heating element.

for problem areas...



HYDRONIC FLOOR BOX HEATER recesses neatly into the floor for uninterrupted heating comfort at patio doors and floor length windows. Ask for publication HFB-10

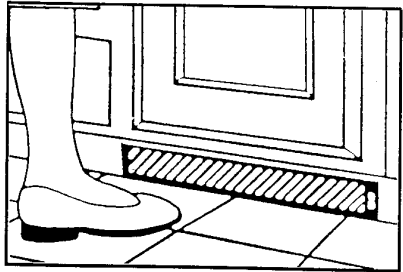

THE KICKER multi-purpose fan convection heater fits in kickspace under kitchen cabinets or bathroom vanities. Ask for publication TK-10

fine points using enclosure only...

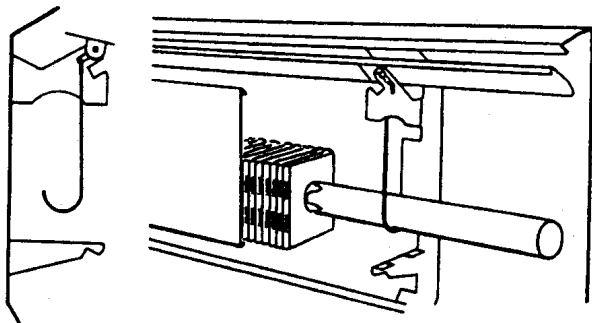

Use Slant/Fin hanger to support the bare tubing at the same height as adjoining heating elements. Insert the short hook of the hanger as shown. Install from the left side, so that the large hook (which holds the tubing) faces the rear panel.

when a normal loop can't be run...

In some installations, it's not possible to drop the return line below the floor. In this case, run the return tubing within the baseboard enclosure. Support with wire hanger which you can shorten to hold the tubing in the space between the heating element and bracket arm. For Base/Line 2000, a special cutout in the bracket arm accommodates return tubing. Use a Slant/Fin return bend to connect the heating element with the return line above it. This fitting has a convenient $\frac{1}{8}$ " IPS threaded opening to receive an air vent.

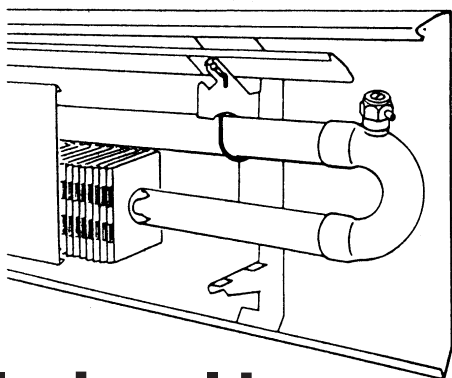

Note: If the baseboard is installed below the boiler level, as in many slab jobs, the return bend may be installed with the vent opening pointed downward, and plugged. This permits easy drainage if needed.

replacing old standing radiators...

A handy illustrated guide from Slant/Fin helps you figure how many feet of baseboard it takes to equal the heat output of most styles of standing cast-iron radiators. Ask for publication RC-40.

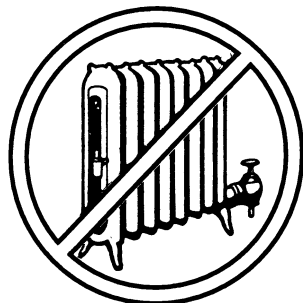

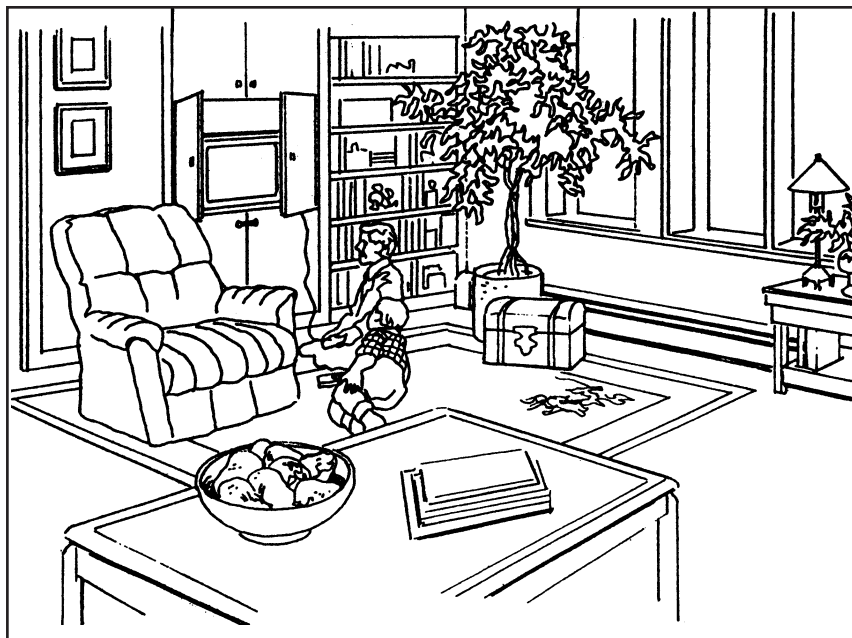

...wasn't that easy?

©Slant/Fin Corp. 1994. Printed in USA 103. Publication No. BB-40

www.slantfin.com

Slant/Fin[®]

America's No. 1 brand of
baseboard convection heating

SLANT/FIN CORPORATION, Greenvale, N.Y. 11548 • Phone: (516) 484-2600