



PS10-1A Single Switch - Stock No. 1340101
PS10-2A Double Switch - Stock No. 1340102

UL and CSFM Listed, FM and LPC Approved, NYMEA Accepted, CE Marked

Dimensions: 4 3/4" (12,1cm)W x 2 1/4" (5,7cm)D x 4 3/8" (11,1cm)H

Enclosure: Cover - Die-cast with textured red powdercoat finish
Base - Plated Steel

Pressure Connection: 1/2" NPT Male

Factory Adjustment:

Operates on Pressure increase at 6 ± 1 PSI (0,41 \pm 0,07 BAR)

Operates on Pressure decrease at 5 ± 1 PSI (0,35 \pm 0,07 BAR)

Maximum Differential: 1 PSI (0,06 BAR)

Maximum System Pressure: 250 PSI (17,2 BAR)

Switch Contacts: SPDT (Form C)

15.0 Amps at 125/250VAC, 2.5 Amps at 30VDC

One set in PS10-1A, Two sets in PS10-2A

Environmental Specifications: Indoor or outdoor use

NEMA 4/IP55 Rated Enclosure - when used with proper conduit fittings

Temperature range: -40°F to 140°F (-40°C to 60°C)

(Not for use in hazardous locations)

Service Use:

Automatic Sprinkler

NFPA-13

One or two family dwelling

NFPA-13D

Residential Occupancy up to four stories

NFPA-13R

National Fire Alarm Code

NFPA-72

Tamper: Cover incorporates tamper resistant fasteners that require a special key for removal. One key is supplied with each device. For optional cover tamper switch kit, order Stock No. 0090134.

INSTALLATION AND TEST PROCEDURES

The Potter PS10A Series Pressure Actuated Switches are designed for the detection of a waterflow condition in automatic fire sprinkler systems of particular designs such as wet systems with alarm check valves or dry pipe systems. They may also be used to provide a low pressure supervisory signal. They may be adjusted to operate on pressure between 4 and 20 PSI (0,27 and 0,4 BAR).

MOUNTING: Device should be mounted in upright position (threaded connection down). Requires NEMA type 4 conduit hub for outdoor installations.

TESTING: The operation of the pressure alarm switch should be tested upon completion of installation and periodically thereafter in accordance with the applicable NFPA codes and standards and/or the authority having jurisdiction (manufacturer recommends quarterly or more frequently).

WET SYSTEM:

METHOD 1: When using PS10A and control unit with retard - connect PS10A into alarm port piping on the input side of retard chamber and electrically connect PS10A to control unit that provides a retard to compensate for surges. Insure that no unsupervised shut-off valves are present between the alarm check valve and PS10A.

METHOD 2: When using the PS10A for local bell application or with a control that does not provide a retard feature - the PS10A must be

installed on the alarm outlet side of the retard chamber of the sprinkler system.

TESTING: Accomplished by opening the inspector's end-of-line test valve. Allow time to compensate for system or control retard.

CAUTION: Method 2 is not applicable for remote station service use, if there is an unsupervised shut-off valve between the alarm check valve and the PS10A.

WET SYSTEM WITH EXCESS PRESSURE:

Connect PS10A into alarm port piping extending from alarm check valve. Retard provisions are not required. Insure that no unsupervised shut-off valves are present between the alarm check valve and the PS10A.

TESTING: Accomplished by opening the water by-pass test valve or the inspector's end-of-line test valve. When using end-of-line test, allow time for excess pressure to bleed off.

DRY SYSTEM:

Connect PS10A into alarm port piping that extends from the intermediate chamber of the alarm check valve. Install on the outlet side of the in-line check valve of the alarm port piping. Insure that no unsupervised shut-off valves are present between the alarm check valve and the PS10A.

TESTING: Accomplished by opening the water by-pass test valve.

CAUTION: The above tests may also activate any other circuit closer or water motor gongs that are present on the system.

DIMENSIONS

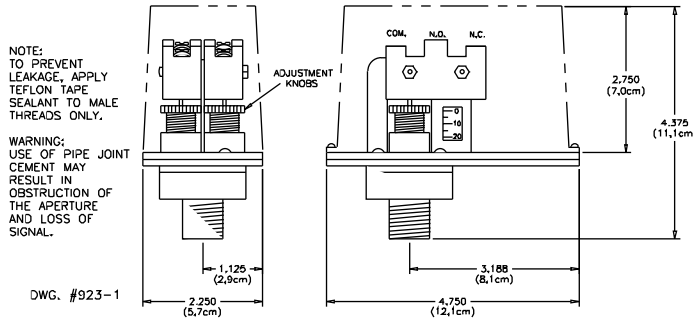

SWITCH TERMINAL CONNECTIONS CLAMPING PLATE TERMINAL

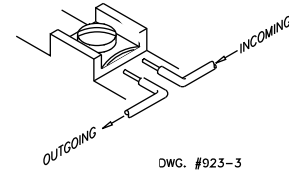

CAUTION:

An uninsulated section of a single conductor should not be looped around the terminal and serve as two separate connections. The wire must be severed, thereby providing supervision of the connection in the event that the wire becomes dislodged from under the terminal.

TYPICAL SPRINKLER APPLICATIONS

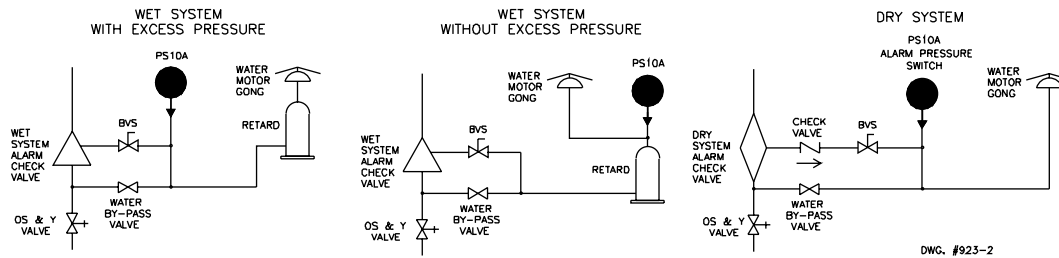

CAUTION: Closing of any shutoff valves between the alarm check valve and the PS10A will render the PS10A inoperative. To comply with NFPA-72 any such valve shall be electrically supervised with a supervisory switch such as Potter Model BVS.

TYPICAL ELECTRICAL CONNECTIONS

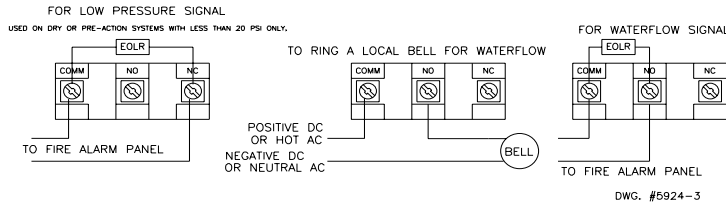

ORDERING INFORMATION

Model No.	Description	Stock
PS10-1A	Pressure switch with one set SPDT contacts	1340101
PS10-2A	Pressure switch with two sets SPDT contacts	1340102
	Hex Key	5250062
	Cover Tamper Switch Kit	0090134
BVS	1/2" Ball Valve with tamper switch	1010150

APPLICATION WARNING!

Due to the possibility of unintended discharges caused by pressure surges, trapped air, or short retard times, waterflow switches that are monitoring wet pipe sprinkler systems should not be used as the sole initiating device to discharge AFFF, deluge, or chemical suppression systems.

ENGINEER/ARCHITECT SPECIFICATIONS

Pressure type waterflow switches shall be a Model PS10A as manufactured by Potter Electric Signal Co. of St. Louis, Mo. and shall be installed on the sprinkler systems as shown on the drawings and/or specified herein.

Switches shall be provided with a 1/2" NPT male pressure connection to be connected into the alarm check valve of a "wet" sprinkler system or into the intermediate chamber of a "dry" pipe system and shall be actuated by any flow of water to or in excess of the discharge from one sprinkler head.

Switches shall have a maximum service pressure rating of 250 PSI (17,2 BAR) and shall be factory adjusted to operate on pressure increase at 6 ± 1 PSI ($0,4 \pm 0,06$ BAR). There shall be one (1) or two (2) SPDT contacts rated at 15.0 Amps at 125/250VAC and 2.5 Amps at 30VDC.

The switch housing shall be weather proof and oil resistant. The cover shall incorporate tamper resistant screws.

The unit shall be UL and CSFM Listed, FM and LPC Approved, and NYMEA Accepted.

PRESSURE SWITCH TERMINATION

