



BRADFORD WHITE[®]
W A T E R H E A T E R S

**COMMERCIAL STORAGE TANK
REPLACEMENT PARTS LIST
80, 120 and 200 Gallon Models**



*Effective: January, 2019
ECO 8240*

**NOTE: BOTH MODEL AND SERIAL
NUMBERS ARE REQUIRED FOR
ORDERING REPLACEMENT PARTS**

Dimensions and specifications
subject to change without notice.



As required by the state of California Proposition 65.

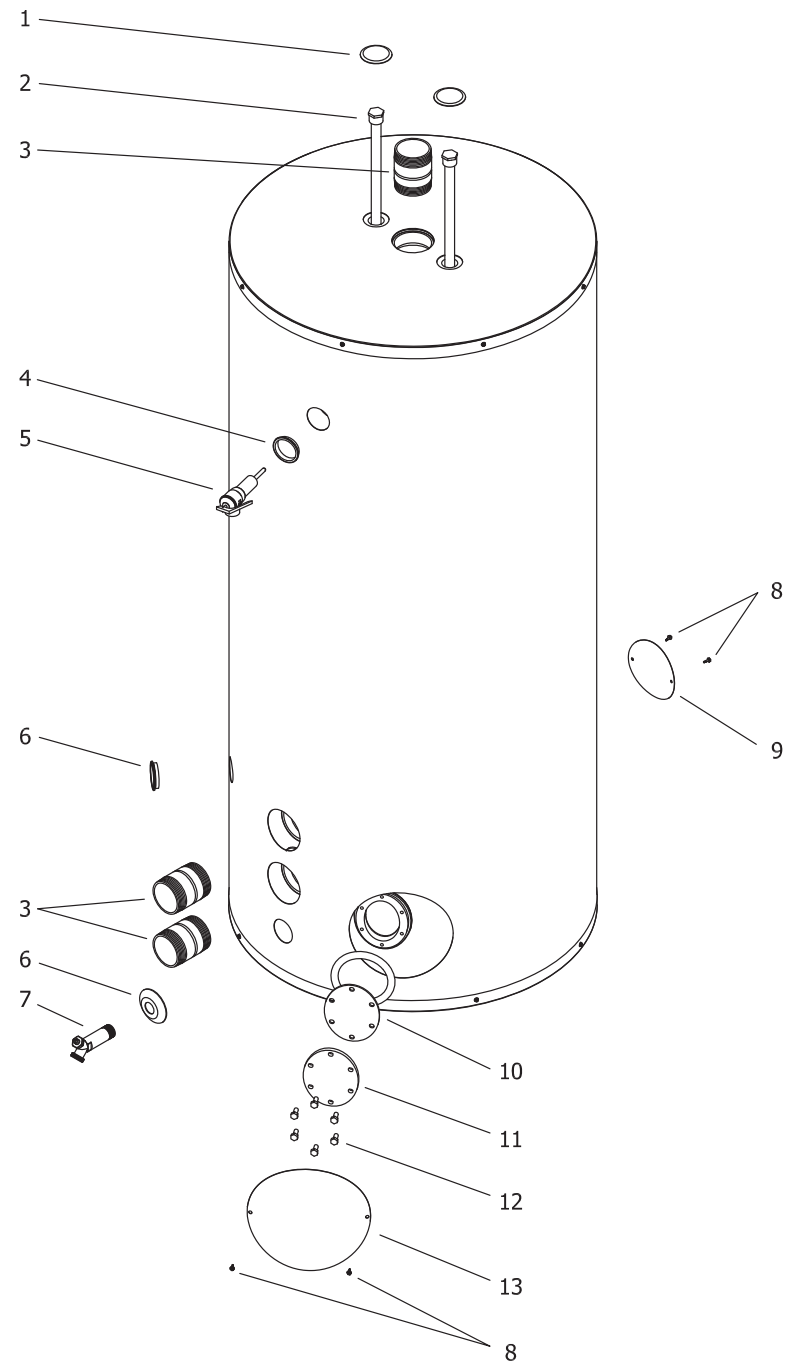

Item	Description	Model	Model	Model	Model
		M3ST80R5A	M3ST120R5	M3ST120R5A	M3ST200R5A
1	Hole Closure	N/A	239-31547-02	239-31547-02	239-31547-02
2	Anode Rod (Magnesium)#	224-47782-08	224-47782-08	224-47782-08	224-47782-12
	Anode Rod (Aluminum) (Optional)#	224-47783-08	224-47783-08	224-47783-08	224-47783-08
	Anode Rod (A420) (Optional)#	224-49559-04	224-49559-04	224-49559-04	224-49559-04
3	Inlet/Outlet Nipple 2" NPT X 3 1/2	229-32762-17	229-32762-17	229-32762-17	---
	Inlet/Outlet Nipple 2 1/2" NPT X 3 1/2 (Optional)	---	229-32762-22	229-32762-22	229-32762-22
4	Trim Ring-Grey	239-32793-05	239-32793-05	239-32793-05	239-32793-05
5	T&P Relief Valve*	---	---	---	---
6	Finished Flange	239-41414-00	239-41414-00	239-41414-00	239-41414-00
7	Brass Drain Valve	265-42351-02	265-42351-04	265-42351-04	265-42351-04
8	Screw #8-18 x 1/2	239-32761-00	239-32761-00	239-32761-00	239-32761-00
9	Cover Aux.	---	243-47670-00	243-47670-00	---
10	Clean Out O-Ring Gasket	---	205-18427-00	---	---
	Clean Out Gasket (ASME)	205-32942-00	---	205-32942-00	205-32942-00
11	Clean Out Cover	---	205-18428-00	---	---
	Clean Out Cover (ASME)	205-32941-00	---	205-32941-00	205-32941-00
12	Clean Out Cover Screws	---	239-82166-00	---	---
	Clean Out Cover Screws (ASME)	239-32970-00	---	239-32970-00	239-32970-00
13	Clean Out Access Cover	243-20299-00	243-20299-00	243-20299-00	243-20299-00
14	Escutcheon-2"	---	---	---	---

* A combination temperature and pressure relief valve is required by code as a protective device. It is not normally supplied by the tank manufacturer as original equipment. It is traditionally provided by the installer and is shown here for replacement parts purposes. The T&P valve for these storage tanks must be rated for the BTU input of the heater of the system where installed. P/N 230-33630-04 T&P valve 1" NPT female thread rated for 750,000 BTU.

Anode may need to be cut to length

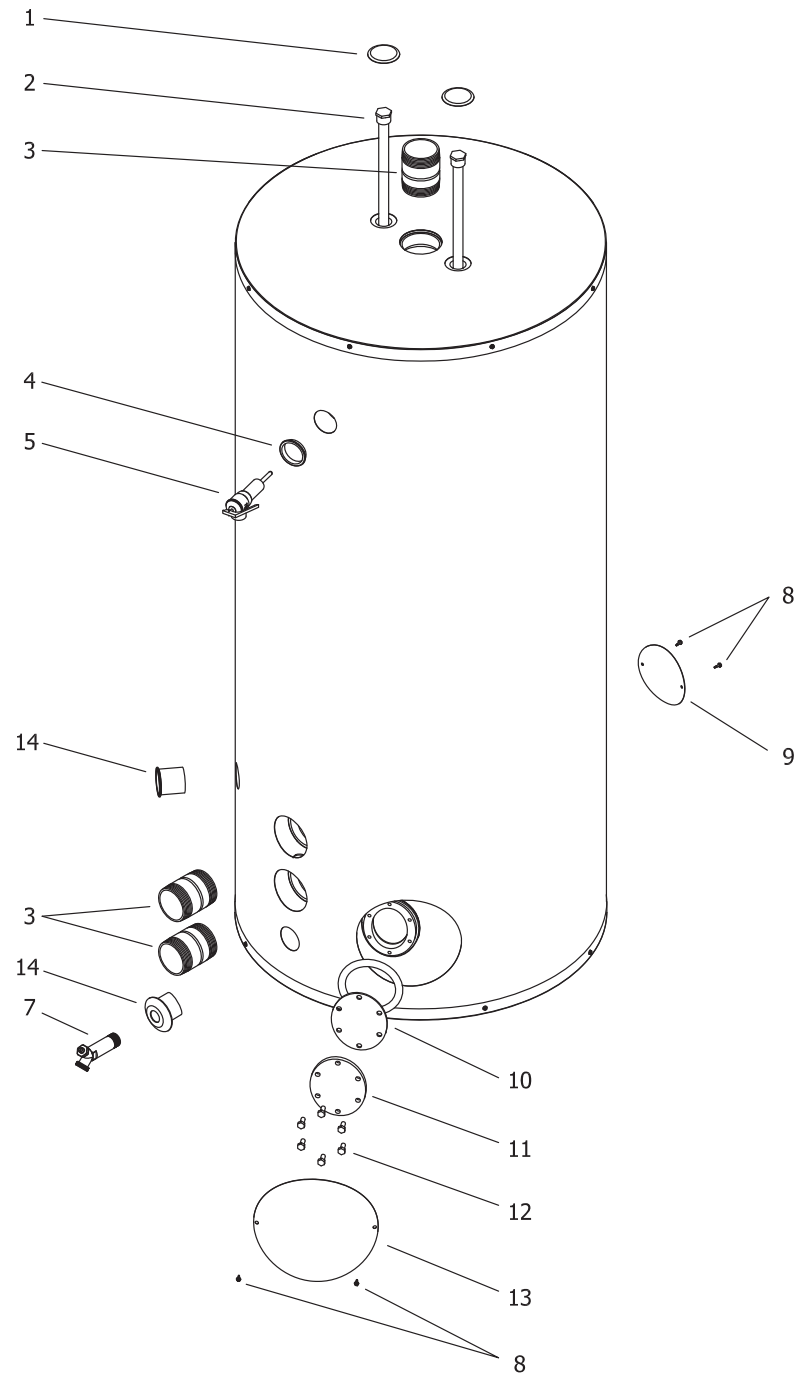

Item	Description	Model
		M3ST80R5
1	Hole Closure	N/A
2	Anode Rod (Magnesium)#	224-47782-08
	Anode Rod (Aluminum) (Optional)#	224-47783-08
	Anode Rod (A420) (Optional)#	224-49559-04
3	Inlet/Outlet Nipple 2" NPT X 3 1/2	229-32762-17
	Inlet/Outlet Nipple 2 1/2" NPT X 3 1/2 (Optional)	---
4	Trim Ring-Grey	239-32793-05
5	T&P Relief Valve*	---
6	Finished Flange	---
7	Brass Drain Valve	265-42351-02
8	Screw #8-18 x 1/2	239-32761-00
9	Cover Aux.	---
10	Clean Out O-Ring Gasket	205-18427-00
	Clean Out Gasket (ASME)	---
11	Clean Out Cover	205-18428-00
	Clean Out Cover (ASME)	---
12	Clean Out Cover Screws	239-82166-00
	Clean Out Cover Screws (ASME)	---
13	Clean Out Access Cover	243-20299-00
14	Escutcheon-2"	239-41337-00

* A combination temperature and pressure relief valve is required by code as a protective device. It is not normally supplied by the tank manufacturer as original equipment. It is traditionally provided by the installer and is shown here for replacement parts purposes. The T&P valve for these storage tanks must be rated for the BTU input of the heater of the system where installed. P/N 230-33630-04 T&P valve 1" NPT female thread rated for 750,000 BTU.

Anode may need to be cut to length



BRADFORD WHITE®

W A T E R H E A T E R S

Ambler, PA

For U.S. and Canada field service,
contact your professional installer or
local Bradford White sales representative.

Sales/800-523-2931

Technical Support/800-334-3393
Email/techserv@bradfordwhite.com

Warranty/800-531-2111
Email/warranty@bradfordwhite.com

Service Parts/800-538-2020
Email/Parts@bradfordwhite.com

International:
international@bradfordwhite.com



BRADFORD WHITE™

CANADA

Halton Hills, Ontario, Canada

Sales & Technical Support/866-690-0961
905-203-0600

Fax/905-636-0666

Email

Warranty/bwccwarranty@bradfordwhite.com
Technical Support/BWCCTech@bradfordwhite.com
Parts/orders@bradfordwhitecanada.com
Orders/ca.orders@bradfordwhite.com

www.bradfordwhite.com