



Fantech

Your Ventilation Solutions Company

Installation Instructions for Model DBF4XL Dryer Exhaust Booster

READ & SAVE THESE INSTRUCTIONS!

Installation Guidelines

Please note: DBF4XL fans **are not** explosion proof. **Do not use the fans if a potentially explosive situation may exist. DO NOT USE with heated air in excess 140°F (60°C).**

Do not install in an exhaust ductwork where the equivalent duct length is < 25 feet (7.62 meters). The DBF4XL is suitable to overcome an equivalent duct length of 130 feet (40 meters) of 4 inch diameter galvanized steel duct, and to maintain a air velocity of 1200fpm (6.10 m/s).

Calculating Duct Run

To calculate the length of your planned duct run, measure from the dryer to external venting point in roof or wall. For each bend or elbow add 5-7 feet to your total duct run calculations. The DBF4XL can be used on runs up to 130 feet.

Fan and Switch Mounting

The recommended location of the booster fan is a minimum of 15 linear (not equivalent) feet of duct from the dryer outlet. If the fan is mounted closer than the recommended 15 feet, it may develop enough pressure to lift wet lint into the fan impeller resulting in excessive lint loading in the fan. The best location for the fan to be mounted is as close as possible to the termination of the duct work. Exception: If a secondary lint filter is installed between the dryer and the booster fan, the booster fan may be mounted within the minimum distance otherwise recommended (See illustration on right). A mounting bracket (included) attached to a rafter or joist should be used to stabilize the fan. Although not recommended, a vertical rigid duct may support the fan if the duct is securely stabilized. (Consult local codes prior to supporting the fan in the duct alone.) It is recommended that duct work be attached to the inlet and outlet of the fan by means of **FC** vibration isolation clamps (optional) to permit periodic inspection of the blower. Refer to maintenance instructions for inspection recommendations. All duct connections should be properly sealed to prevent leakage and loss of fan performance. Flex duct connections between the dryer duct connection and exhaust duct should be stretched as smooth as possible.

Pressure Sensor Switch Operation

The DBF4XL contains a positive pressure sensing switch which recognizes dryer operation and activates the booster fan from an independent electrical circuit. This eliminates connections through the dryer circuit which may void the manufacturers' warranty as well as manual systems which require the attention of the operator or costly current/temperature sensing systems.

Power to the booster fan is connected in series through a normally open terminal on the switch. A pressure tap is connected to a nipple on the side of the switch. When the dryer begins operation, positive pressure in the duct causes the switch diaphragm to expand closing the circuit to the booster fan. An integral delay-on-break timer in the switch will cycle the fan on for intervals of 10 minutes. Cycle will reinitiate after a few seconds as long as the dryer is operating. This will continue until the dryer has stopped and the timer delay period has lapsed. Drying cycles, the booster fan, the delay timer and the pressure switch are not adversely affected by the starting/stopping intervals.



Includes:

- 1 DBF4XL Dryer Exhaust Booster
- 1 Fan Mounting Bracket and Hardware
- 1 Wall Label (Mount on wall near dryer.)
- 1 Tubing & Grommet

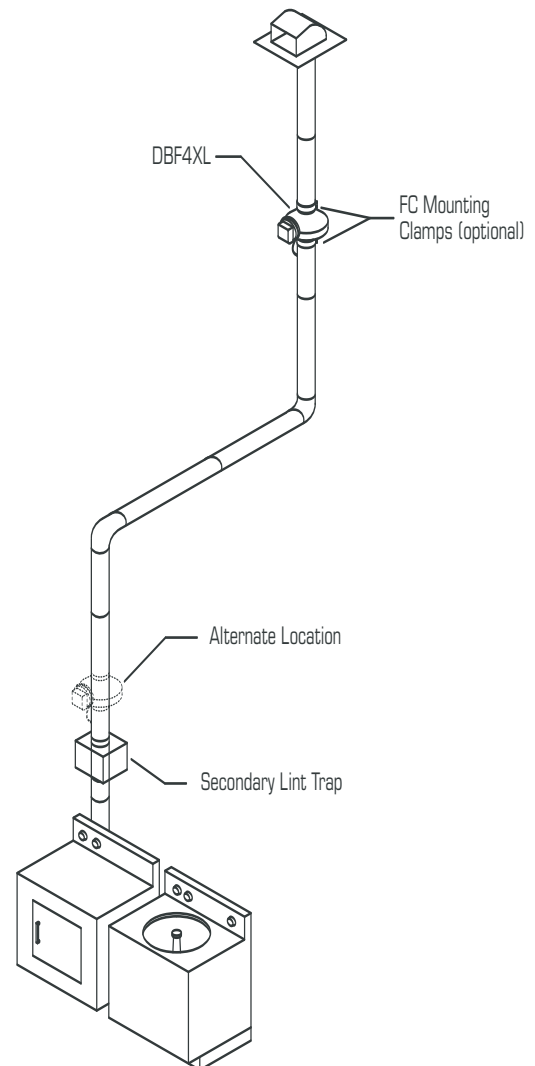

DBF4XL FAN/SWITCH INSTALLATION INSTRUCTIONS

Fan Installation

Step 1. Selecting Fan Location

Fan **must** be mounted a minimum of 15 feet from the dryer outlet. *If the fan is mounted closer than the recommended 15 feet, it may develop enough pressure to lift wet lint into the fan impeller resulting in excessive lint loading in the fan.* *Note: See exception on the front page of these instructions. In any application, the fan should be mounted as close as possible to the termination of the duct work. In order to perform recommended maintenance, fan location should allow sufficient access for service. Refer to dimensional drawings shown below.

Step 2. Mount Bracket

Using the wood screws provided, attach the mounting bracket to a support beam at the selected location. Fan mounting can be in any angle, however, vertical mounting is recommended to reduce condensation buildup in the fan. If a horizontal installation is necessary and condensation buildup may pose a problem, a 1/4" hole drilled in the bottom of the housing (along with an NPT insert and drain tubing) will allow condensation to drain.

Step 3. Mount Fan

For proper operation, the switch diaphragm should be positioned vertically. (Illustrations below show diaphragm position for horizontal, vertical and ducts installed at an angle.) Wiring box should be positioned for easy access. Attach fan to the mounting bracket with the self tapping screws provided. Care should be taken not to strip the housing. Although screw pilot holes are not required, 3/32" (or smaller) pilot holes are recommended.

NOTE: Steps 2 & 3 may be reversed.

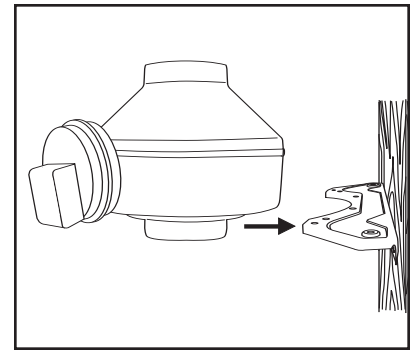

Mount Bracket

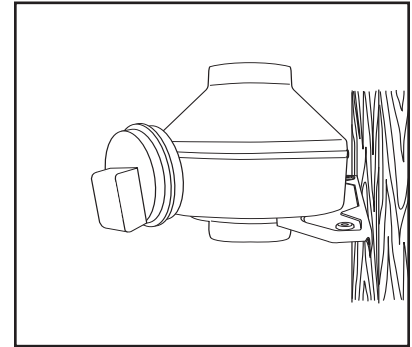

Mount Fan

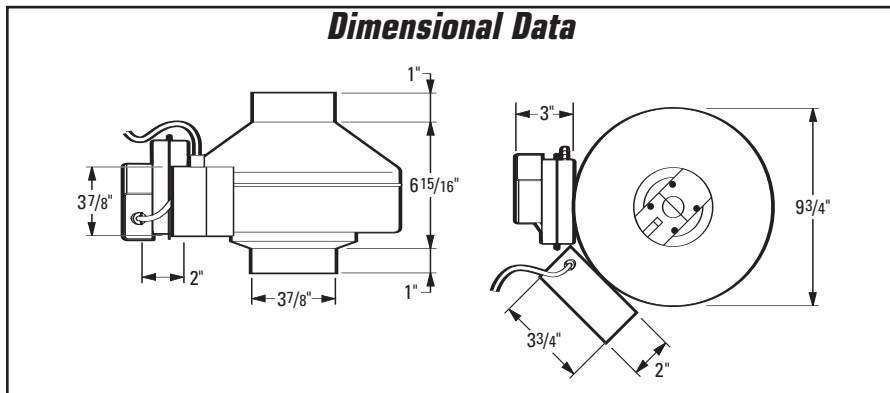

Dimensions in inches.

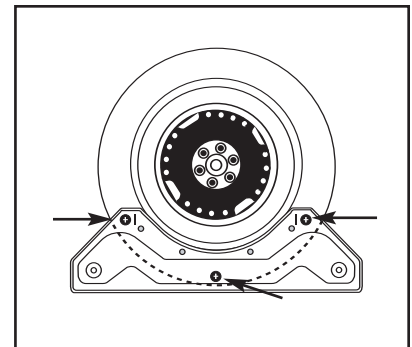

Mounting Bracket & Screw Locations

Pressure Switch Positioning

Correct Switch Positioning - Diaphragm Positioned Vertically

Horizontal Duct

Angled Duct

Vertical Duct

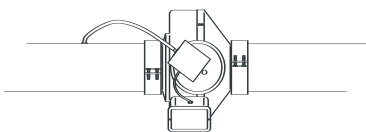

Correct Diaphragm Positioning

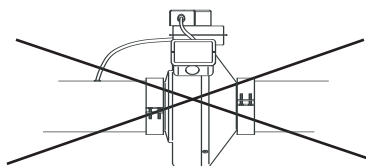

Incorrect Diaphragm Positioning

Correct Diaphragm Positioning

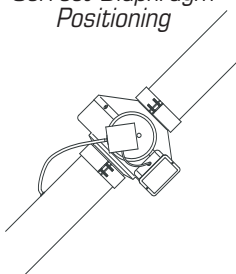

Incorrect Diaphragm Positioning

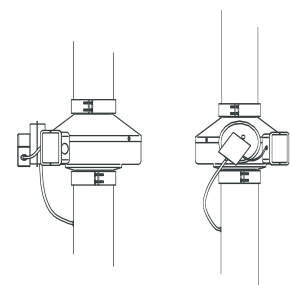
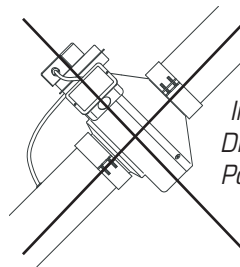

Diaphragm Correct in all Positions

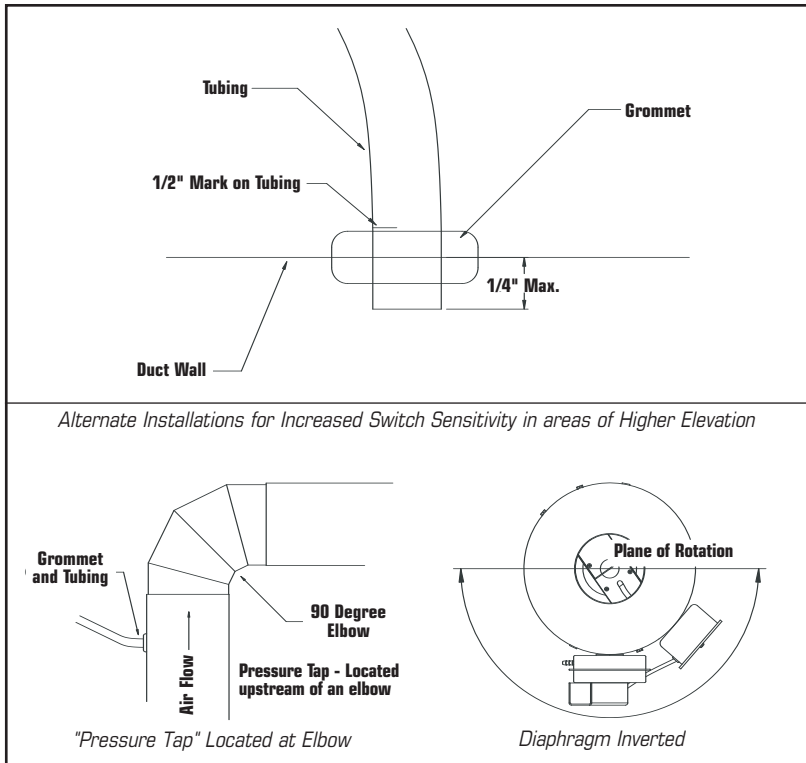

Installing Grommet and Tubing

First, drill a 5/16 inch to 3/8 inch diameter hole in the duct wall. Carefully insert the grommet into the hole. (Drilling a metal duct may produce burrs. Be careful not to be cut or pricked by the burrs or the duct.) Next, force one end of the tubing over the nipple on the switch. It may be necessary to use a lubricant in order to slide the tubing over the entire nipple. Make a mark a distance of 1/2 inch from the other end of the tubing. Slide this end of the tubing through the center of the grommet up to the mark as illustrated. *Do not use a lubricant on this end of the tubing.*

In order to increase the switch sensitivity for installations in regions of higher elevation, it may be necessary to rotate the diaphragm as illustrated. The diaphragm should be located below the horizontal axis. Please note that due to gravity, the switch may not release when the diaphragm is fully inverted. The diaphragm should be rotated in increments and cycled to be certain that the switch will release thereby breaking power to the fan. An alternate approach may be to insert the "pressure tap" in the upstream side of an elbow. Additional tubing may be required. In the event that additional tubing is required, be certain that the tubing connections at the duct wall and the switch are as air-tight as possible by sealing with a caulking material.

Electrical Connection

DO NOT CONNECT POWER SUPPLY UNTIL FAN IS COMPLETELY INSTALLED. The DBF4XL is provided with a 120VAC power cord.

1. This unit has rotating parts and safety precautions should be exercised during installation, operation and maintenance.
2. **CAUTION:** "For General Ventilation Use Only. Do Not Use To Exhaust Hazardous Or Explosive Materials And Vapors."
3. **WARNING: TO REDUCE THE RISK OF FIRE, ELECTRIC SHOCK, OR INJURY TO PERSONS - OBSERVE THE FOLLOWING:**
 - a. Use this unit only in the manner intended by the manufacturer. If you have questions, contact the factory.
 - b. Before servicing or cleaning, unplug power cord or switch power off at service panel and lock service panel to prevent fan from being switched on accidentally. When the service disconnecting means cannot be locked, securely fasten a prominent warning device, such as a tag, to the service panel.
 - c. Installation work and electrical wiring must be done by qualified person(s) in accordance with all applicable codes and standards, including fire-rated construction.
 - d. The combustion airflow needed for safe operation of fuel burning equipment may be affected by this unit's operation. Follow the heating equipment manufacturer's guidelines and safety standards such as those published by the National Fire Protection Association (NFPA), the American Society of Heating, Refrigeration, and Air Conditioning Engineers (ASHRAE) and the local code authorities.
 - e. When cutting or drilling into wall or ceiling, do not damage electrical wires or other hidden utilities.
 - f. Ducted fans must always be vented to the outdoors.
4. **WARNING!** Check voltage at the fan to see if it corresponds to the motor nameplate.
GUARDS MUST BE INSTALLED WHEN FAN IS WITHIN REACH OF PERSONNEL OR WITHIN SEVEN (7) FEET OF WORKING LEVEL OR WHEN DEEMED ADVISABLE FOR SAFETY.

Recommended Maintenance

1. Since fan bearings are sealed and provided with an internal lubricating material, no additional lubrication is necessary.
2. Fan impeller may accumulate lint. Periodic inspection, based upon dryer usage, should be performed to ensure that the fan impeller is not obstructed or loaded with lint. Under normal conditions, fan should be inspected a minimum of every Six (6) Months. *Note: Excessive booster fan noise or vibration may be an indication of lint buildup on the impeller.* To inspect and clean the impeller:
 - a. Disconnect the incoming power supply at the source.
 - b. Remove the duct from the fan inlet and remove any lint buildup on the impeller.
 - c. Reconnect the duct to the fan. Turn power supply on.

Troubleshooting

Important Notice: Prior to performing Steps 1 - 3, be certain that the electrical supply to the fan/switch is turned off.

If fan fails to start when the dryer cycle begins, please follow the procedure listed below:

1. Check the incoming supply for proper voltage.
2. Turn on the electrical supply and restart the dryer cycle. Check to be certain that fan starts.

If fan still fails to start after performing Steps 1 - 4, continue following the procedure as listed below:

3. Verify that the pressure switch diaphragm is vertical as illustrated on Page 2 of these instructions. If the diaphragm is not vertical, reposition the pressure switch and check for fan operation against another dryer cycle.
4. Verify that the tubing is not crimped and that the tubing connector nipples are not obstructed.
5. If switch diaphragm is vertical and fan still fails to start, with the electrical supply on:
 - a. Remove the tubing from the nipple on the fan and blow gently into the tubing;
 - b. If fan starts, consult Fantech for additional technical support.
 - c. If fan fails to start, please consult Fantech for additional technical support.

FIVE (5) YEAR WARRANTY

This warranty supersedes all prior warranties

DURING ENTIRE WARRANTY PERIOD:

FANTECH will repair or replace any part which has a factory defect in workmanship or material. Product may need to be returned to the fantech factory, together with a copy of the bill of sale and identified with RMA number.

FOR FACTORY RETURN YOU MUST:

Have a Return Materials Authorization (RMA) number. This may be obtained by calling FANTECH either in the USA at 1.800.747.1762 or in CANADA at 1.800.565.3548. Please have bill of sale available.

- The RMA number must be clearly written on the outside of the carton, or the carton will be refused.
- All parts and/or product will be repaired/replaced and shipped back to buyer; no credit will be issued.

OR

The Distributor may place an order for the warranty part and/or product and is invoiced. The Distributor will receive a credit equal to the invoice only after product is returned prepaid and verified to be defective.

FANTECH WARRANTY TERMS DO NOT PROVIDE FOR REPLACEMENT WITHOUT CHARGE PRIOR TO INSPECTION FOR A DEFECT. REPLACEMENTS ISSUED IN ADVANCE OF DEFECT INSPECTION ARE INVOICED, AND CREDIT IS PENDING INSPECTION OF RETURNED MATERIAL. DEFECTIVE MATERIAL RETURNED BY END USERS SHOULD NOT BE REPLACED BY THE DISTRIBUTOR WITHOUT CHARGE TO THE END USER, AS CREDIT TO DISTRIBUTOR'S ACCOUNT WILL BE PENDING INSPECTION AND VERIFICATION OF ACTUAL DEFECT BY FANTECH. THE FOLLOWING WARRANTIES DO NOT APPLY:

- Damages from shipping, either concealed or visible. Claim must be filed with freight company.
- Damages resulting from improper wiring or installation.
- Damages or failure caused by acts of God, or resulting from improper consumer procedures, such as:
 1. Improper maintenance
 2. Misuse, abuse, abnormal use, or accident, and
 3. Incorrect electrical voltage or current.
- Removal or any alteration made on the FANTECH label control number or date of manufacture.
- Any other warranty, expressed, implied or written, and to any consequential or incidental damages, loss or property, revenues, or profit, or costs of removal, installation or reinstallation, for any breach of warranty.

WARRANTY VALIDATION

- The user must keep a copy of the bill of sale to verify purchase date.
- These warranties give you specific legal rights, and are subject to an applicable consumer protection legislation. You may have additional rights which vary from state to state.



United States
1712 Northgate Blvd.,
Sarasota, FL. 34234
Phone: 800.747.1762; 941.309.6000
Fax: 800.487.9915; 941.309.6099
www.fantech.net; info@fantech.net

Canada
50 Kanalfakt Way,
Bouctouche, NB E4S 3M5
Phone: 800.565.3548; 506.743.9500
Fax: 877.747.8116; 506.743.9600
www.fantech.ca; info@fantech.ca

Fantech, reserves the right to modify, at any time and without notice, any or all of its products' features, designs, components and specifications to maintain their technological leadership position.