

PARTS LIST

BY: AJZ
CHK'D:



FINISH:
DATE:

AS SPECIFIED
07-07-00

1367

REV: 12-28-01

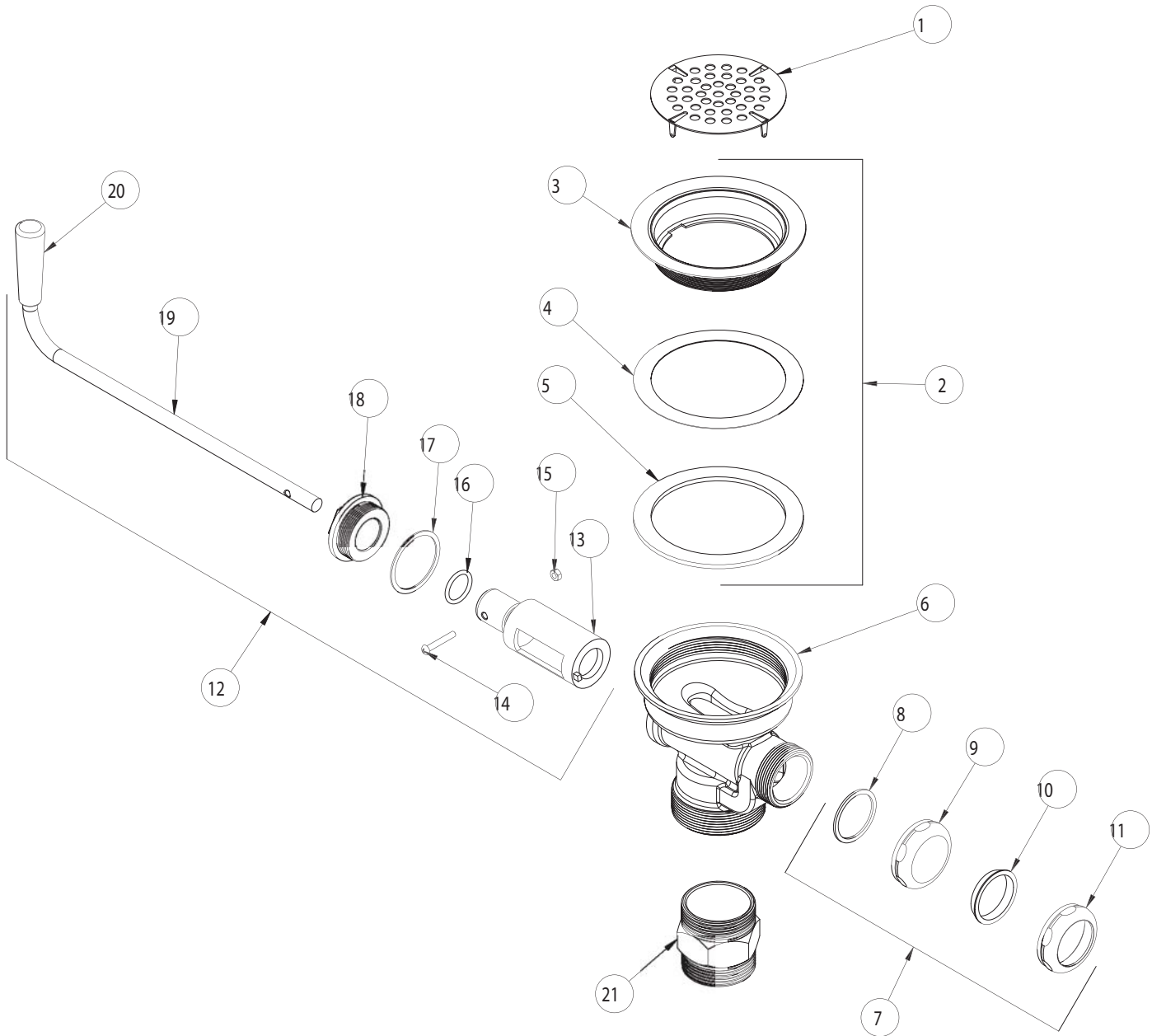

ITEM NO.	PART NO.	DESCRIPTION	ITEM NO.	PART NO.	DESCRIPTION
1	1366-005	3-1/2" FLAT STRAINER PLATE (ST. STL)	12	1367-001K	ROTARY DRAIN HANDLE KIT (INCLUDES 13 - 20)
2	1366-004K	3-1/2" BASKET / SEAL KIT (INCLUDES 3 - 5)	13	-----	BRASS ROTOR
3	-----	3-1/2" FACE FLANGE BASKET (ST. STL)	14	-----	STAINLESS STEEL HANDLE SCREW
4	-----	3-1/2" PAPER WASHER	15	-----	STAINLESS STEEL HANDLE NUT
5	-----	3-1/2" RUBBER GASKET	16	-----	O-RING SEAL
6	-----	CAST BRASS DRAIN BODY	17	-----	FIBER WASHER
7	1366-002K	OVERFLOW KIT (INCLUDES 8 - 11)	18	-----	BRASS PACKING NUT
8	-----	OVERFLOW CAPNUT GASKET	19	-----	STAINLESS STEEL ROTARY HANDLE
9	-----	OVERFLOW CAPNUT	20	-----	BLACK PHENOLIC HANDLE
10	-----	OVERFLOW SLIP WASHER	21	-----	BRASS 1-1/2" NPT NIPPLE
11	-----	OVERFLOW SLIP NUT			