

Regal® Flushometer

NOTE: Also for use with Regal® XL
(Since mid-2010)



The repair kits and parts listed on this page are designed to service all Sloan diaphragm type flushometers, including those manufactured for low consumption (LC) usage.

ABBREVIATIONS:
CP = Chrome plated
gpf = gallons per flush
Lpf = Liters per flush
LC = Low consumption
pkg = package

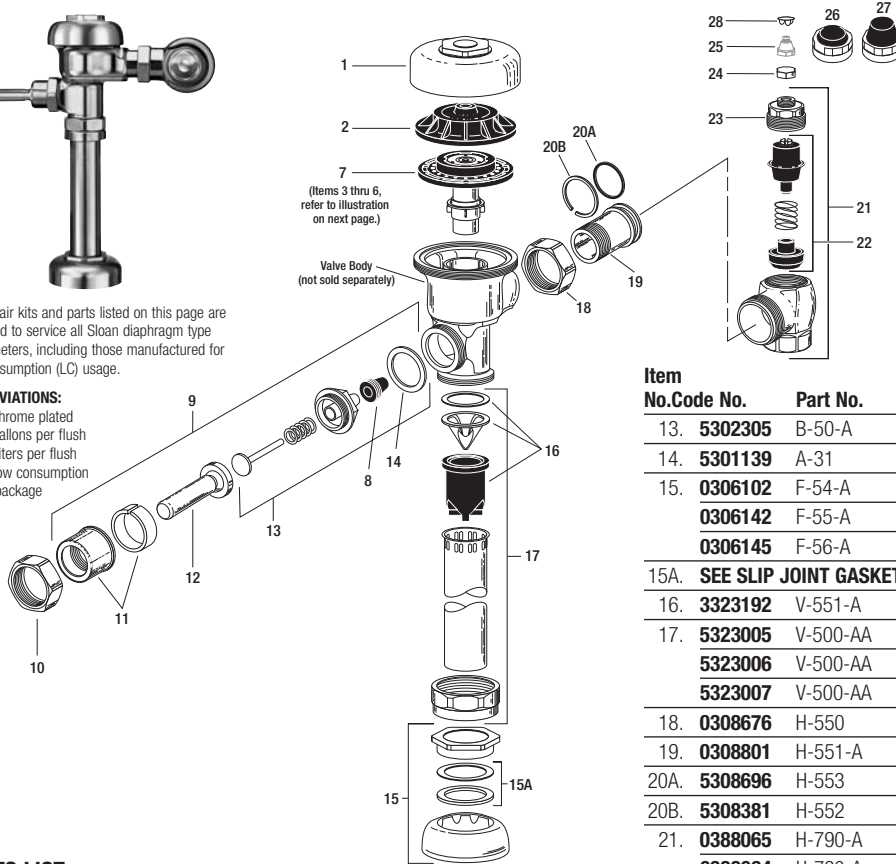

TAILPIECES, CONTROL STOPS AND FLUSH CONNECTIONS

For additional information on tailpieces, control stops and flush connections see Showerheads, Parts and Accessories Tab.

PARTS LIST

Item No.	Code No.	Part No.	Description
1.	0317004	R-10	CP Cover
	—	R-10-HE	CP High Efficiency Cover
2.	0301168	A-71	Inside Cover
SEE ITEMS 3A THROUGH 6E IN CHART ON NEXT PAGE			
3A.	5301058	A-19-AC	Relief Valve, White (Closet) – 12 per package
3B.	5301059	A-19-AU	Relief Valve, Black (Urinal) – 12 per package
3C.	5301211	A-19-ALC	Relief Valve, Green (Closet/Urinal-LC) – 12 per package
3D.	0301143	A-19-AL	Relief Valve, Blue (9 Liter Closet) – 12 per package
4.	5301111	A-15-A	Disc – for all Inside Parts Kits – 12 per package
5.	5301188	A-156-A	Diaphragm – for all Inside Parts Kits – 12 per package
6A.	5301236	A-163-A	Guide Assembly 4.5 gpf/17.0 Lpf Closet & 1.5 gpf/5.7 Lpf Urinal – 12 per package
6B.	5301032	A-152-A	Guide Assembly 3.5 gpf/13.2 Lpf Closet – 12 per package
6C.	5301031	A-151-A	Guide Assembly 1.6 gpf/6.0 Lpf LC Closet – 12 per package
6D.	5301155	A-155-A	Guide Assembly 1.0 gpf/3.8 Lpf LC Urinal – 12 per package
6E.	5301157	A-157-A	Guide Assembly 0.5 gpf/1.9 Lpf Urinal – 12 per package
7.	SEE INSIDE PARTS KITS CHART ON NEXT PAGE		
8.	5302297	B-39	Seal – 12 per package
9.	5302279	B-32-A	CP Handle Assembly – 6 per package
	0302390	B-73-A	CP Handicap Handle Assembly (ADA Compliant)
10.	0301082	A-6	CP Handle Coupling
11.	0302109	B-7-A	CP Socket Assembly
12.	5302274	B-32	CP Handle Grip – 12 per package
	0302389	B-74-A	CP Handicap Handle Grip (ADA Compliant)

Item No.	Code No.	Part No.	Description
13.	5302305	B-50-A	Handle Repair Kit – 6 per package
14.	5301139	A-31	Handle Gasket – 48 per package
15.	0306102	F-54-A	3/4" CP Spud Coupling Assembly
	0306142	F-55-A	1-1/4" CP Spud Coupling Assembly
	0306145	F-56-A	1-1/2" CP Spud Coupling Assembly
15A.	SEE SLIP JOINT GASKETS AND RINGS TABLE BELOW		
16.	3323192	V-551-A	Vacuum Breaker Repair Kit
17.	5323005	V-500-AA	3/4" x 9" CP Vacuum Breaker – 6 per package
	5323006	V-500-AA	1-1/4" x 9" CP Vacuum Breaker – 6 per package
	5323007	V-500-AA	1-1/2" x 9" CP Vacuum Breaker – 6 per package
18.	0308676	H-550	CP Stop Coupling †
19.	0308801	H-551-A	CP Adjustable Tailpiece 2-1/16" long †
20A.	5308696	H-553	O-ring – 24 per package
20B.	5308381	H-552	Locking ring – 12 per package
21.	0388065	H-790-A	1" Screwdriver Bak-Chek® Stop CP – complete
	0388064	H-790-A	3/4" Screwdriver Bak-Chek® Stop CP – complete
	0388029	H-740-A	1" Screwdriver Bak-Chek® Stop CP – OBSOLETE
	0388031	H-740-A	3/4" Screwdriver Bak-Chek® Stop CP – OBSOLETE
22.	3308853	H-541-ASD	1" Control Stop Repair Kit *
	3308856	H-543-ASD	3/4" Control Stop Repair Kit **
23.	0308612	H-622	CP Bonnet (Current Regal)
	0308991	H-639	CP Bonnet – Pre 2010 Regal Stops*
	0308601	H-538	CP Bonnet ** – OBSOLETE
24.	5388001	H-1012-A	CP Cap – 6 per package VP
25.	5310034	J-2/J-7	Bumper Assembly – 6 per package – OBSOLETE
26.	3308866	H-574	Stop Cap, chrome plated with Seat Bumper (-YO)
27.	3308867	H-576	Stop Cap, chrome plated with Extended Seat Bumper (-YG)
28.	5388002	H-528	Hole Plug

† See pages 100-101 for additional lengths

*For use with 1" and 3/4" H-740-A CP (less cap) and 1" – H-540-A CP (with H-37 cap) Bak-Chek® screwdriver control stops

**For use with 3/4" H-740-A CP Bak-Chek® screwdriver control stops

ITEM 15A. SLIP JOINT GASKETS AND RINGS

Size	Code No.	Part No.	Description
1-1/2"	5306058	F-3	Red Friction Ring
	5322001	VBF-5	Black Slip Joint Gasket
	0319086/5319086	S-30	Flexible Seat
1-1/2" x 1-1/4"	0319079	S-21	Rigid Seat (rubber over brass)
	0396062	F-105	Slip Joint Gasket – Rigid
1-1/4"	5306057	F-3	Red Friction Ring
	5322176	VBF-5	Black Slip Joint Gasket
1"	0307052/5307052	G-21	Rigid Seat (rubber over brass)
	5306056	F-3	Red Friction Ring
3/4"	5306115	F-5	Black Slip Joint Gasket
	5306055	F-3	Red Friction Ring
	5306113	F-5	Black Slip Joint Gasket

Regal® Flushometer

NOTE: Also for use with Regal® XL
(Since mid-2010)

Manual
Flushometers

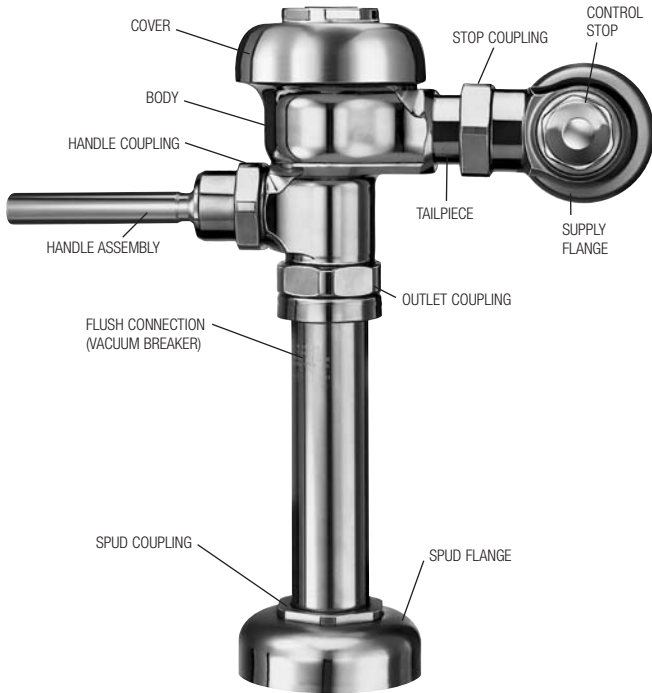

MASTER FLUSHOMETER REBUILDING KITS (SEE PARTS LIST – ON PREVIOUS PAGE)

Refer to Parts List. Includes Items 7, 13, 16 & 20

Code No.	Part No.	Description
3317001	R-1001-A	Rebuild Kit (4.5 gpf/17.0 Lpf) Closet/Service Sink
3317002	R-1002-A	Rebuild Kit (1.5 gpf/5.7 Lpf) Urinal
3317003	R-1003-A	Rebuild Kit (3.5 gpf/13.2 Lpf) Closet
3317004	R-1004-A	Rebuild Kit (1.6 gpf/6.0 Lpf) Closet
3317005	R-1005-A	Rebuild Kit (1.0 gpf/3.8 Lpf) LC Urinal
3317011	R-1011-A	Rebuild Kit (0.5 gpf/1.9 Lpf) Urinal
3317012	R-1012-A	Rebuild Kit (2.4 gpf/9.0 Lpf) Closet

REPAIR KIT WASHER SET (SEE PARTS LIST – ON PREVIOUS PAGE)

5301189	A-156-AA	Repair Kit Washer Set – Includes: 4, 5, 8 & 14
----------------	----------	--

ITEM 7. INSIDE PARTS KITS (SEE ILLUSTRATIONS BELOW)

Item No.	Code No.	Part No.	Application
A.	3301036	A-36-A	4.5 gpf/17.0 Lpf - Closet
B.	3301037	A-37-A	1.5 gpf/5.7 Lpf - Urinal
C.	3301038	A-38-A	3.5 gpf/13.2 Lpf - Closet
D.	3301041	A-41-A	1.6 gpf/6.0 Lpf - Closet
E.	3301044	A-42-A	1.0 gpf/3.8 Lpf - Urinal
F.	3301081	A-43-A	0.5 gpf/1.9 Lpf - Urinal
G.	3301024	A-44-A	2.4 gpf/9.0 Lpf - Closet

ITEM 7. INSIDE PARTS COMPONENTS (SEE ILLUSTRATIONS BELOW)

Item No.	Code No.	Part No.	Description
3A.	5301058	A-19-AC	Relief Valve, White (Closet) – 12 per pkg.
3B.	5301059	A-19-AU	Relief Valve, Black (Urinal) – 12 per pkg.
3C.	5301211	A-19-ALC	Relief Valve, Green (Closet/Urinal-LC) – 12 per pkg.
3D.	0301143	A-19-AL	Relief Valve, Blue (9 Liter Closet) – 12 per pkg.
4.	5301111	A-15-A	Disc – for all Inside Parts Kits – 12 per pkg.
5.	5301188	A-156-A	Diaphragm – for all Inside Parts Kits – 12 per pkg.
6A.	5301236	A-163-A	Guide Assembly 4.5 gpf/17.0 Lpf Closet & 1.5 gpf/5.7 Lpf Urinal – 12 per package
6B.	5301032	A-152-A	Guide Assembly 3.5 gpf/13.2 Lpf Closet – 12 per package
6C.	5301031	A-151-A	Guide Assembly 1.6 gpf/6.0 Lpf LC Closet – 12 per package
6D.	5301155	A-155-A	Guide Assembly 1.0 gpf/3.8 Lpf LC Urinal – 12 per package
6E.	5301157	A-157-A	Guide Assembly 0.5 gpf/1.9 Lpf Urinal – 12 per package

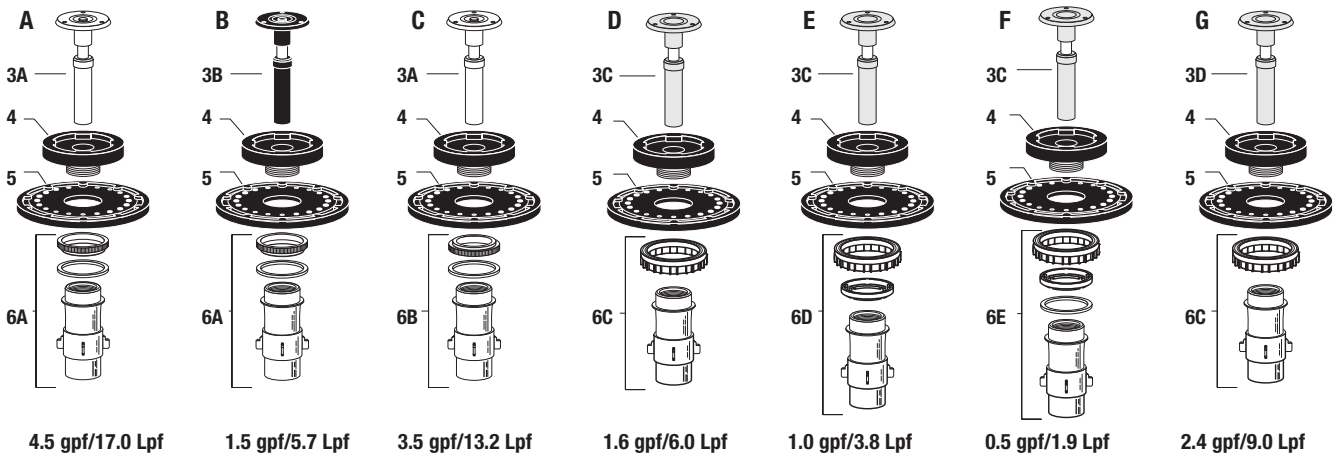

Regal® Flushometer

NOTE: Also for use with Regal® XL
(Since mid-2010)

TROUBLESHOOTING GUIDE

ATTENTION INSTALLERS: With the exception of the control stop inlet, DO NOT USE pipe sealant or plumbing grease on any valve component or coupling! To protect the chrome or special finish of Sloan flushometers, DO NOT USE toothed tools to install or service these valves. Use our A-50 Super-Wrench™ or other smooth-jawed wrench to secure couplings. Regulations for low consumption fixtures (1.6 gpf/6.0 Lpf closets and 1.0 gpf/3.8 Lpf urinals) prohibit use of higher flush volumes.

1. Flushometer does not function.

- Control stop or main valve is closed. Open control stop or main valve.
- Handle assembly is worn. Install handle repair kit B-50-A or replace handle.
- Relief valve is worn. Replace inside parts kit.

2. Insufficient volume of water to adequately siphon fixture.

- Control stop not open enough. Adjust control stop for desired delivery of water.
- Urinal flushometer parts inside a closet flushometer. Replace inside urinal parts with proper closet flushometer parts.
- Low consumption flushometer installed on a non-low consumption fixture. Replace A-41-A inside parts kit with A-38-A water saver kit.
- Water saver kit installed in old, non-water saver bowl. Position refill head A-170-1 so that SIDE 1 is in the UP position.
- Inadequate volume or pressure at supply. If no gauges are available to properly measure supply pressure or volume of water at the flushometer, then remove the relief valve from the inside parts kit, reassemble the flushometer and open the control stop.
 - If the fixture siphons, more water volume is required. If a 3.5 gpf inside parts kit is installed in the flushometer, then first flip the refill head (under the diaphragm) to obtain a 4.5 gpf volume. If this volume is still inadequate, remove the flow ring from the guide to obtain a 6.5 gpf kit. If additional flow is still required, try a low pressure guide kit A-175-A. **IMPORTANT: LAWS AND REGULATIONS PROHIBIT THE USE OF HIGHER FLUSHING VOLUMES THAN LISTED ON FIXTURE OR FLUSHOMETER.**
 - If fixture does not siphon or if a low consumption fixture is installed, or if the above steps do not prove satisfactory, steps must be taken to increase the pressure and/or supply.

3. Flushometer closes off immediately.

- Ruptured or damaged diaphragm. Install inside parts kit to correct above problems and update flushometer.
- Enlarged by-pass orifice from corrosion or damage. Install inside parts kit to correct above problem and update flushometer.

4. Length of flush is too short (short flushing).

- Diaphragm assembly and guide assembly are not hand-tight. Screw the two assemblies hand-tight.
- Enlarged by-pass orifice from corrosion or damage. Install NEW inside parts kit to correct problem and update flushometer.
- A-19-AU (black) urinal relief valve in closet flushometer. Replace relief valve with A-19-AC (white) closet relief valve.
- B-41-A low consumption kit installed in non-low consumption fixture. Replace with proper inside parts kit.
- Handle assembly is worn. Install handle repair kit B-50-A or replace the handle.

5. Length of flush is too long (long flushing) or fails to close off.

- Relief valve is not seating properly or by-pass orifice is clogged because of foreign material, or by-pass orifice is closed by an invisible gelatinous film from "over-treated" water. Disassemble the working parts and wash thoroughly.
NOTE: SIZE OF ORIFICE IN THE BY-PASS IS EXTREMELY IMPORTANT FOR PROPER METERING OF WATER INTO THE UPPER CHAMBER OF THE FLUSHOMETER. DO NOT ENLARGE OR DAMAGE THIS ORIFICE. REPLACE INSIDE KIT IF CLEANING DOES NOT CORRECT PROBLEM.
- Line pressure has dropped and is not sufficient to force relief valve to seat. Shut off all control stops until pressure has been restored, then open them again.
- A-19-AC (white) closet relief valve has been used in a 1 or 1-1/2 gpf urinal. Replace with A-19-AU (black) relief valve.
- Inside cover is cracked or damaged. Replace the inside cover A-71.

6. Chattering noise in flushometer.

- The A-156-A segment diaphragm has been installed upside-down. Replace the segment diaphragm to the proper position as instructed by markings on the diaphragm.
- The inside cover has been distorted from wear, freezing or abuse. replace inside cover.

7. Leaking at handle assembly.

- The B-39 seal is worn or deteriorated. Install new B-39 seal.
NOTE: The B-39 seal will easily slide right onto the B-40 bushing if it is wet.
- Handle gasket has been omitted. Install A-31 handle gasket or handle repair kit B-50-A.
- Valve handle bushing is worn. Install handle repair kit B-50-A.

CARE AND CLEANING INSTRUCTIONS

DO NOT use abrasive or chemical cleaners to clean flushometers, they may dull the luster and attack the chrome or special decorative finishes. Use ONLY mild soap and water, then wipe dry with a clean towel or cloth.

While cleaning the bathroom tile, the flushometer should be protected from any splattering of cleaner. Acids and cleaning fluids can discolor or remove chrome plating.

When assistance is required, please contact

Sloan Technical Support at: 1-888-SLOAN-14 (1-888-756-2614).