

INSTALLER: THESE INSTRUCTIONS MUST BE CONVEYED TO AND REMAIN WITH THE HOMEOWNER.

CERTIFIED UNDER CANADIAN AND AMERICAN NATIONAL STANDARDS,
CSA 2.33 AND ANSI Z21.88 RESPECTIVELY FOR GAS-FIRED VENTED GAS FIREPLACE HEATER



QUALITY FIREPLACES

VENTED GAS FIREPLACE HEATER DIRECT VENT MILLIVOLT SYSTEM

INSTALLATION AND OPERATION INSTRUCTIONS FOR:

NATURAL GAS *MODEL **GD70NT***

PROPANE GAS *MODEL **GD70PT***

CERTIFIED FOR CANADA AND UNITED STATES USING ANSI / AGA / CGA METHODS

WARNING: If the information in these instructions is not followed exactly, a fire or explosion may result causing property damage, personal injury or death.

FOR YOUR SAFETY

Do not store or use gasoline or other flammable vapours and liquids in the vicinity of this or any other appliance.

WHAT TO DO IF YOU SMELL GAS:

- Do not try to light any appliance.
- Do not touch any electrical switch.
- Do not use any phone in your building.
- Immediately call your gas supplier from a neighbor's phone. Follow the gas supplier's instructions.
- If you cannot reach your gas supplier, call the fire department.

Installation and service must be performed by a qualified installer, service agency or the gas supplier.

**Wolf Steel Ltd., 9 Napoleon Rd.,
Barrie, ON., Canada L4M 4Y8 (705)721-1212**

Fax: (705)722-6031 Email: ask@napoleon.on.ca

Web: www.napoleonfireplaces.com





TABLE of CONTENTS

PG2-5	INTRODUCTION Warranty General Instructions General Information Care of Glass & Plated Parts	15	OPTIONAL BLOWER INSTALLATION
5-7	VENTING Vent lengths Special Installation Example Air Terminal Locations	16	OPTIONAL FAN & THERMOSTATIC SENSOR
8-12	INSTALLATION/FRAMING Wall & Ceiling Protection Using Flexible Vent Components Fireplace Vent Connection Using Rigid Vent Components Gas Installation Mobile Home Installation Framing	17-18	OPERATION / MAINTENANCE Operating Instructions Maintenance
12-14	FINISHING Door Installation Door Opening and Closing Optional Louvre, Ornamental Inset & Face Plate Installation Log Placement/Charcoal Embers	18	ADJUSTMENTS Pilot Burner Adjustment Venturi Adjustment
		19, 20 & 21	REPLACEMENTS Ordering Replacement Parts Replacement Parts Terminal Kits Vent Kits Accessories
		22-23	TROUBLE SHOOTING GUIDE
		24	SERVICE HISTORY

PLEASE RETAIN THIS MANUAL FOR FUTURE REFERENCE

WARNING

- Do not burn wood or other materials in this fireplace.
- Adults and especially children should be alerted to the hazards of high surface temperatures and should stay away to avoid burns or clothing ignition. Supervise young children when they are in the same room as the fireplace.
- Due to high temperatures, the fireplace should be located out of traffic and away from furniture and draperies.
- Clothing or other flammable material should not be placed on or near the fireplace.
- Any safety screen or guard removed for servicing must be replaced prior to operating the fireplace.
- It is imperative that the control compartments, burners and circulating blower and its passageway in the fireplace and venting system are kept clean. The fireplace and its venting system should be inspected before use and at least annually by a qualified service person. More frequent cleaning may be required due to excessive lint from carpeting, bedding material, etc. The fireplace area must be kept clear and free from combustible materials, gasoline and other flammable vapours and liquids.
- Under no circumstances should this fireplace be modified.
- This fireplace must not be connected to a chimney flue pipe serving a separate solid fuel burning appliance.
- Do not use this fireplace if any part has been under water. Immediately call a qualified service technician to inspect the fireplace and to replace any part of the control system and any gas control which has been under water.
- Do not operate the fireplace with the glass door removed, cracked or broken. Replacement of the glass should be done by a licensed or qualified service person.
- Do not strike or slam shut the fireplace glass door.

NOTE: Changes, other than editorial, are denoted by a vertical line in the margin.

NAPOLEON gas fireplaces are manufactured under the strict Standard of the world recognized ISO9002 Quality Assurance Certificate.

NAPOLEON products are designed with superior components and materials, assembled by trained craftsmen who take great pride in their work. The burner and valve assembly are leak and test-fired at a quality test station. The complete fireplace is thoroughly inspected by a qualified technician before packaging to ensure that you, the customer, receives the quality product that you expect from NAPOLEON.

NAPOLEON GAS FIREPLACE PRESIDENT'S LIFETIME LIMITED WARRANTY

The following materials and workmanship in your new napoleon gas fireplace are warranted against defects for as long as you own the fireplace. This covers: combustion chamber, heat exchanger, stainless steel burner, PHAZER™ logs and embers, ceramic glass (thermal breakage only), gold plated parts against tarnishing, porcelainized enamelled components and aluminum extrusion trims.

Electrical (110V and millivolt) components and wearable parts such as the blower, gas valve, thermal switch, switches, wiring, remote control, ignitor, gasketing, and pilot assembly are covered and NAPOLEON will provide replacement parts free of charge during the first year of the limited warranty.

Labour related to warranty repair is covered free of charge during the first year. Repair work, however, requires the prior approval of an authorized company official. Labour costs to the account of NAPOLEON are based on a pre-determined rate schedule and any repair work must be done through an authorized NAPOLEON dealer.

CONDITIONS AND LIMITATIONS

NAPOLEON warrants its products against manufacturing defects to the original purchaser only -- i.e., the individual or legal entity (registered customer) whose name appears on the warranty registration card filed with NAPOLEON -- provided that the purchase was made through an authorized NAPOLEON dealer and is subject to the following conditions and limitations:

This factory warranty is nontransferable and may not be extended whatsoever by any of our representatives.

The gas fireplace must be installed by a licenced, authorized service technician or contractor. Installation must be done in accordance with the installation instructions included with the product and all local and national building and fire codes.

This limited warranty does not cover damages caused by misuse, lack of maintenance, accident, alterations, abuse or neglect and parts installed from other manufacturers will nullify this warranty.

This limited warranty further does not cover any scratches, dents, corrosion or discolouring caused by excessive heat, abrasive and chemical cleaners nor chipping on porcelain enamel parts, mechanical breakage of PHAZER™ logs and embers, nor any venting components used in the installation of the fireplace.

NAPOLEON warrants its stainless steel burners against defects in workmanship and material for life, subject to the following conditions: During the first 10 years NAPOLEON will replace or repair the defective parts at our option free of charge. From 10 years to life, NAPOLEON will provide replacement burners at 50% of the current retail price.

In the first year only, this warranty extends to the repair or replacement of warranted parts which are defective in material or workmanship provided that the product has been operated in accordance with the operation instructions and under normal conditions.

After the first year, with respect to this President's Limited Lifetime Warranty, NAPOLEON may, at its discretion, fully discharge all obligations with respect to this warranty by refunding to the original warranted purchaser the wholesale price of any warranted but defective part(s).

After the first year, NAPOLEON will not be responsible for installation, labour or any other costs or expenses related to the reinstallation of a warranted part, and such expenses are not covered by this warranty.

Notwithstanding any provisions contained in this President's Limited Lifetime Warranty, NAPOLEON'S responsibility under this warranty is defined as above and it shall not in any event extend to any incidental, consequential or indirect damages.

This warranty defines the obligations and liability of NAPOLEON with respect to the NAPOLEON gas fireplace and any other warranties expressed or implied with respect to this product, its components or accessories are excluded.

NAPOLEON neither assumes, nor authorizes any third party to assume, on its behalf, any other liabilities with respect to the sale of this product. NAPOLEON will not be responsible for: over-firing, downdrafts, spillage caused by environmental conditions such as rooftops, buildings, nearby trees, hills, mountains, inadequate vents or ventilation, excessive venting configurations, insufficient makeup air, or negative air pressures which may or may not be caused by mechanical systems such as exhaust fans, furnaces, clothes dryers, etc.

Any damages to fireplace, combustion chamber, heat exchanger, brass trim or other component due to water, weather damage, long periods of dampness, condensation, damaging chemicals or cleaners will not be the responsibility of NAPOLEON.

The bill of sale or copy will be required together with a serial number and a model number when making any warranty claims from your authorized dealer. The warranty registration card must be returned within fourteen days to register the warranty.

NAPOLEON reserves the right to have its representative inspect any product or part thereof prior to honouring any warranty claim.

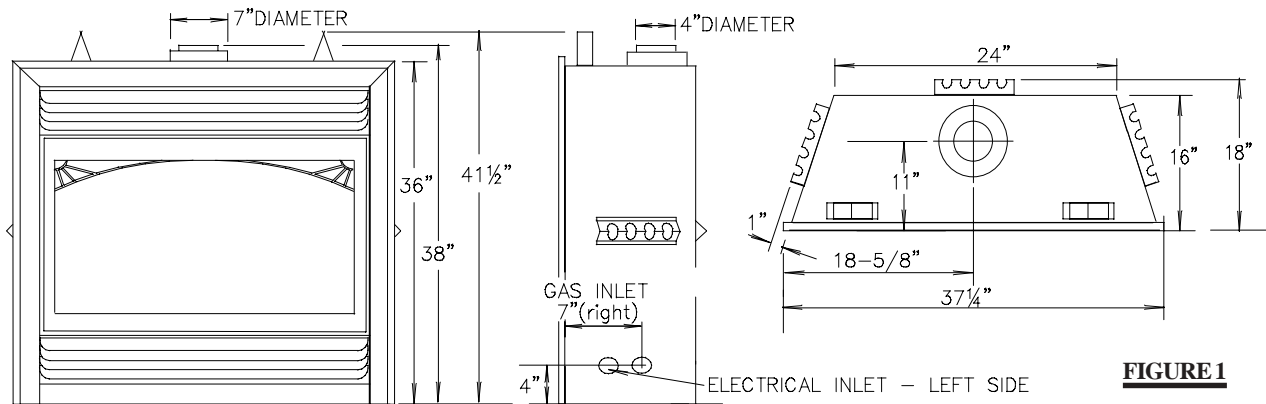

FIGURE 1

WARNING: The door for this fireplace is sold separately. The door must be installed and closed before operation begins. Refer to "DOOR INSTALLATION" under the "FINISHING" Section for details.

GENERAL INSTRUCTIONS

THIS GAS FIREPLACE SHOULD BE INSTALLED AND SERVICED BY A QUALIFIED INSTALLER to conform with local codes. Installation practices vary from region to region and it is important to know the specifics that apply to your area, *ie:* in Massachusetts State:

- The fireplace damper must be removed or welded in the open position prior to installation of a fireplace insert.
- The appliance off valve must be a "T" handle gas cock.
- The flexible connector must not be longer than 36 inches.
- The appliance is not approved for installation in a bedroom or bathroom unless unit is direct-vent. In absence of local codes, install to the current CAN/CGA -B149 Installation Code in Canada or to the National Fuel Gas Code, ANSI Z223.1-1988, and NFPA 54-1988 in the United States. Suitable for mobile home installation if installed in accordance with the current standard CAN/CSA Z240MH Series, for gas equipped mobile homes, in Canada or ANSI Z223.1-1988 and NFPA 54-1988 in the United States.

The fireplace and its individual shutoff valve must be disconnected from the gas supply piping system during any pressure testing of that system at test pressures in excess of 1/2 psig (3.5 kPa). The fireplace must be isolated from the gas supply piping system by closing its individual manual shutoff valve during any pressure testing of the gas supply piping system at test pressures equal to or less than 1/2 psig (3.5 kPa).

When the fireplace is installed directly on carpeting, vinyl tile or other combustible material other than wood flooring, the fireplace shall be installed on a metal or wood panel extending the full width and depth.

The optional heat circulating blower is supplied with a cord. If installed, the junction box must be electrically connected and grounded in accordance with local codes. In the absence of local codes, use the current CSA C22.1 CANADIAN ELECTRICAL CODE in Canada or the ANSI/NFPA 70-1996 NATIONAL ELECTRICAL CODE in the United States.

Purge all gas lines with the glass door of the fireplace open. Assure that a continuous gas flow is at the burner before closing the door.

Under extreme vent configurations, allow several minutes (5-15) for the flame to stabilize after ignition.

Eight (8") inches is the minimum bend radius allowed for the 7" diameter flexible air liner.

W415-0272/B/10.18.01

Provide adequate ventilation and combustion air. Provide adequate accessibility clearance for servicing and operating the fireplace. Never obstruct the front opening of the fireplace.

Objects placed in front of the fireplace must be kept a minimum of 48" from the front face of the unit.

Minimum clearance to combustible construction from fireplace and vent surfaces:

- fireplace framing - 0" to stand-offs (top, rear and sides)
- fireplace finishing - 3" to sides, 7 1/4" to top of unit
- vent pipe - 2 inches *
- recessed depth - 16 inches

* The first 2 feet of outer 7 inch diameter vent pipe from the appliance must be wrapped in the 1" thick insulation sleeve (supplied). There must be a 1 inch air gap in addition to the insulation sleeve. See Figure 28.

GENERAL INFORMATION

FOR YOUR SATISFACTION, THIS FIREPLACE HAS BEEN TEST-FIRED TO ASSURE ITS OPERATION AND QUALITY!

Maximum input is 35,000 BTU/hr for natural gas and 33,000 BTU/h for propane. When the fireplace is installed at elevations above 4,500ft, and in the absence of specific recommendations from the local authority having jurisdiction, the certified high altitude input rating shall be reduced at the rate of 4% for each additional 1,000ft. Maximum output for natural gas is 28,350 BTU/hr at an efficiency of 81%; and 26,400 BTU/hr for propane at an efficiency of 80%. Minimum A.F.U.E. rating is 64% for natural gas and 65% for propane. Minimum inlet gas supply pressure is 4.5 inches water column for natural gas and 11 inches water column for propane. Maximum inlet gas pressure is 7 inches water column for natural gas and 13 inches water column for propane. Manifold pressure under flow conditions is 3.5 inches water column for natural gas and 10 inches water column for propane. This fireplace is approved for bathroom, bedroom and bed-sitting room installations and is suitable for mobile home installation. The natural gas model can only be installed in a mobile home that is permanently positioned on its site and fueled with natural gas.

This fireplace may be installed in an aftermarket permanently located, manufactured (mobile) home, where not prohibited by local codes.

This fireplace is only for use with the type of gas indicated on the rating plate. This fireplace is not convertible for use with other gases, unless a certified kit is used.

No external electricity (110 volts or 24 volts) is required for the gas system operation.

Expansion / contraction noises during heating up and cooling down cycles are normal and are to be expected. Change in flame appearance from "HI" to "LO" is more evident in natural gas than in propane.

CARE OF GLASS AND PLATED PARTS

Do not use abrasive cleaners to clean plated parts. Buff lightly with a clean dry cloth. The glass is 3/16" ceramic glass available from your Napoleon / Wolf Steel Ltd. dealer. DO NOT SUBSTITUTE MATERIALS. Clean the glass after the first 10 hours of operation with a recommended gas fireplace glass cleaner. Thereafter clean as required. DO NOT CLEAN GLASS WHEN HOT! If the glass is not kept clean permanent discoloration and / or blemishes may result.

VENTING

VENTING LENGTHS AND AIR TERMINAL LOCATIONS

Use only Napoleon or Simpson Dura-Vent Model DV-GS venting components. Minimum and maximum vent lengths, for both horizontal and vertical installations, and air terminal locations for these installations, are set out in this manual and must be adhered to. For Simpson Dura-Vent, follow the installation procedure provided with the venting components.

When using Napoleon venting components, use only approved Wolf Steel Ltd. rigid / flexible vent components with the following termination kits: WALL TERMINAL KIT **GD222**, or 1/12 TO 7/12 PITCH ROOF TERMINAL KIT **GD110**, 8/12 TO 12/12 ROOF TERMINAL KIT **GD111**, FLAT ROOF TERMINAL KIT **GD112** or PERISCOPE KIT **GD201** (for wall penetration below grade). With flexible venting, in conjunction with the various terminations, use either the 5 foot vent kit **GD220** or the 10 foot vent kit **GD330**. These vent kits allow for either horizontal or vertical venting of the fireplace. **FIGURES 2, 3, & 5.**

The maximum allowable vertical vent length is 40 feet. The maximum number of allowable 4" vent connections is **two horizontally** or **three vertically** (excluding the fireplace and the air terminal connections).

For optimum flame appearance and fireplace performance, keep the vent length and number of elbows to a minimum. The air terminal must remain unobstructed at all times. Examine the air terminal at least once a year to verify that it is unobstructed and undamaged.

*When venting, the horizontal run must be kept to a minimum of 12 inches or a maximum of 20 feet. If a 20 foot horizontal run is required, the fireplace must have a minimum vertical rise immediately off the fireplace of 57 inches. **FIGURES 2a-c.** When terminating vertically, the vertical rise is a minimum 34 inches and a maximum 40 feet above the fireplace. **FIGURE 3.***

Horizontal runs may have a 0 inch rise per foot in all cases using SIMPSON DURA-VENT or NAPOLEON RIGID OR FLEXIBLE venting components when venting as illustrated in Figures 2a, 2b, and 2c.

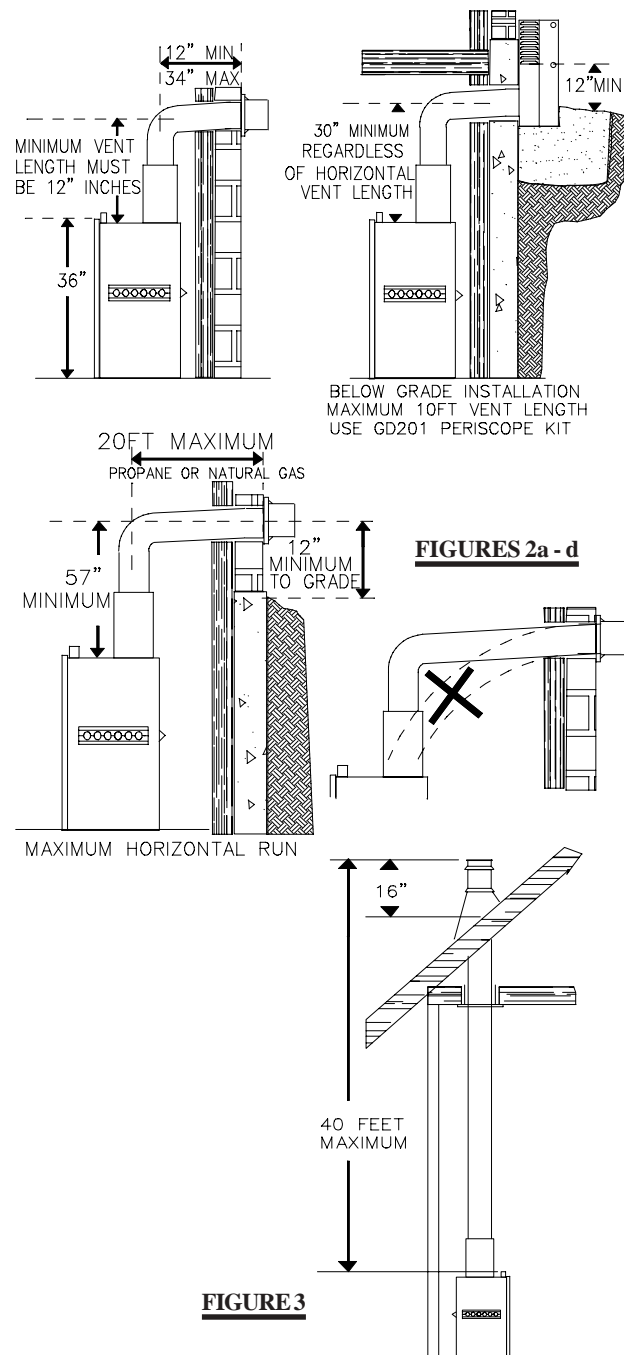

FIGURE 3

6 For optimum performance, it is recommended that all horizontal runs have a minimum ¼ inch rise per foot.

Wolf Steel rigid and flexible venting systems must not be combined. Wolf steel and Simpson Dura-vent venting systems must not be combined.

Provide a means for visually checking the vent connection to the fireplace after the fireplace is installed.

Do not allow the inside liner to bunch up on horizontal or vertical runs and elbows. Keep it pulled tight. A 1¼" air gap between the inner and outer liner all around is required for safe operation.

Vent lengths that pass through unheated spaces (attics, garages, crawl space) should be wrapped with a protective insulation sleeve to minimize condensation.

Use a firestop when penetrating interior walls, floor or ceiling.

In order to avoid the possibility of exposed insulation or vapour barrier coming in contact with the fireplace body, it is recommended that the walls of the fireplace enclosure be "finished", (i.e. drywall/sheetrock) as would any other outside wall of the home. This will ensure that clearance to combustibles is maintained within the cavity.

For safe and proper operation of the fireplace follow the venting instruction exactly.

Deviation from the minimum vertical vent length can create difficulty in burner start-up and/or carboning.

If vertical rises greater than 57 inches are necessary, the increased rise must be deducted from the horizontal run.

Use the chart on this page to calculate horizontal runs for vertical rises between 12 and 57 inches. **FIGURE 4.** When calculating maximum run lengths, include 5 feet for each 90° elbow or 5 feet for each 45° elbow. (DO NOT INCLUDE THE FIRST ELBOW DIRECTLY OFF THE UNIT.)

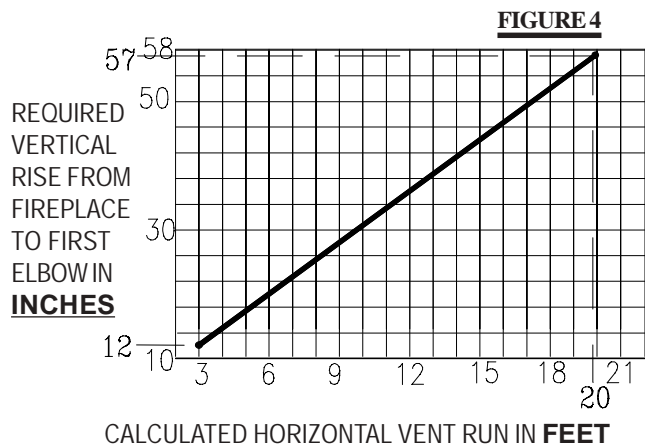

SPECIAL INSTALLATION EXAMPLE

When a horizontal offset is required in a through-the-roof installation, the following procedure for vent length calculations must be followed:

In an installation as shown in **FIGURE 5** lengths A and C are known based on room height and roof requirements.

Length C must never be less than 12 inches. Any 90° and 45° elbows must be calculated as 5 feet of venting each.

The allowable horizontal run can be calculated using these parameters. In this example, the total vertical height is 20 feet (length "A" is required to be 11 feet while length "C" needs to be 9 feet). The maximum vertical length is 40 feet and all runs and elbows must be subtracted from this maximum vertical length.

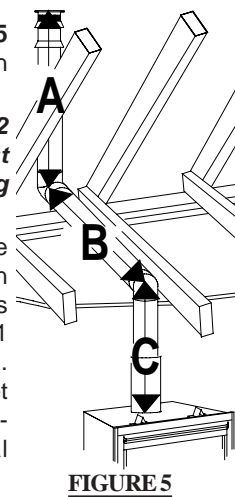

The maximum allowable horizontal run that "B" can be is:

- 40 ft. (maximum vertical run length)**
- 11 ft. (through the roof vertical rise "A")
- 10 ft. (2 - 90° elbow)
- 9 ft. (vertical run "C")
- 10 ft. (maximum allowable horizontal length for "B")

The length of "B" must never be greater than the length of "A" and "C" combined.

Only the following Napoleon Vent Kits, used in combination with each other can be used:

- GD201, GD222, GD110, GD111 or GD112** (Periscope, Wall or Roof Terminals)
- and
- GD220** (5ft vent kit) or/and **GD330** (10ft vent kits)

On all horizontal runs, when determining air terminal locations, check for appropriate rise per foot requirements.

A terminal shall not terminate directly above a sidewalk or paved driveway which is located between two single family dwellings and serves both dwellings. Local codes or regulations may require different clearances.

AIR TERMINAL INSTALLATIONS:

FIGURE 6

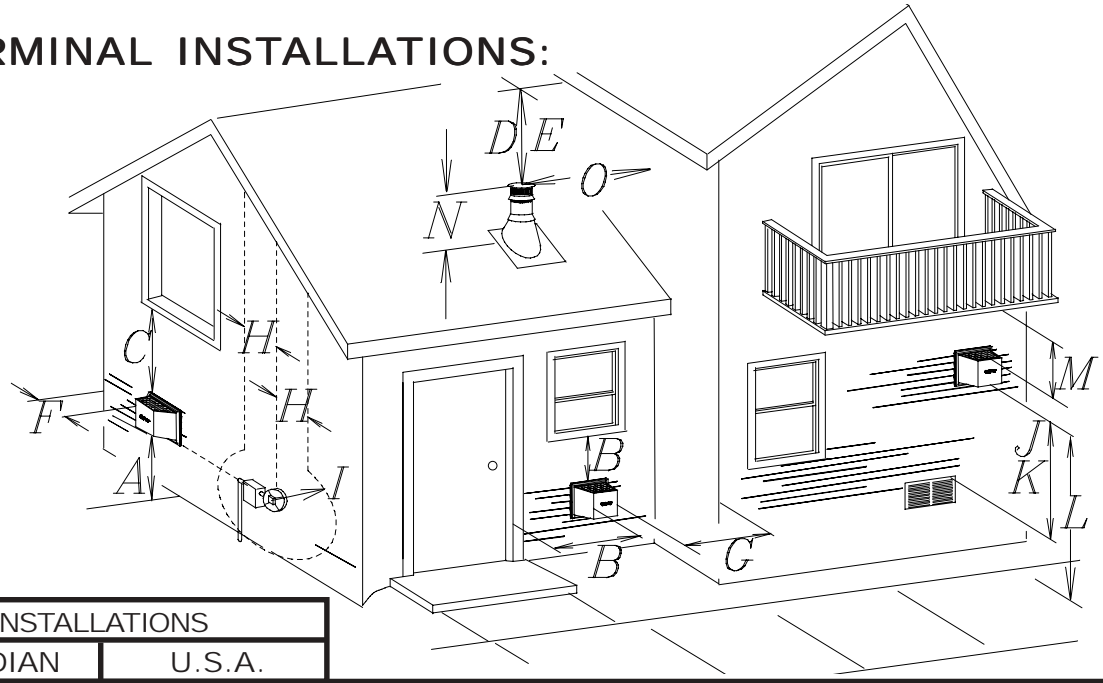

INSTALLATIONS			
	CANADIAN	U.S.A.	
A	12 INCHES	12 INCHES	Clearance above grade, veranda porch, deck or balcony.
B	12 INCHES	9 INCHES	Clearance to windows or doors that open.
C	12 INCHES*	12 INCHES*	Clearance to permanently closed windows.
D	18 INCHES**	18 INCHES**	vertical clearance to ventilated soffit located above the terminal within a horizontal distance of 2 feet from the centerline of the terminal.
E	12 INCHES**	12 INCHES**	Clearance to unventilated soffit.
F	0 INCHES	0 INCHES	Clearance to an outside corner wall.
G	0 INCHES***	0 INCHES***	Clearance to an inside non-combustible corner wall or protruding non-combustible obstructions (chimney, etc.).
	2 INCHES***	2 INCHES***	Clearance to an inside combustible corner wall or protruding combustible obstructions (vent chase, etc.).
H	3 FEET	3 FEET****	Clearance to each side of the centerline extended above the meter / regulator assembly.
I	6 FEET	3 FEET****	Clearance to a service regulator vent outlet.
J	12 INCHES	9 INCHES	Clearance to a non-mechanical air supply inlet to the building or a combustion air inlet to any other appliance.
K	6 FEET	3 FEET†	Clearance to a mechanical air supply inlet.
L	7 FEET‡	7 FEET****	Clearance above a paved sidewalk or paved driveway located on public property unless fitted with a heat shield kit GD-301.
M	12 INCHES††	12 INCHES****	Clearance under a veranda, porch, deck or balcony.
N	16 INCHES	16 INCHES	Clearance above the roof.
O	2 FEET†*	2 FEET†*	Clearance from an adjacent wall including neighbouring buildings.

* Recommended to prevent condensation on windows and thermal breakage
 ** It is recommended to use a heat shield and to maximize the distance to vinyl clad soffits.
 *** The periscope GD-201 requires a minimum 18 inches clearance from an inside corner.
 **** This is a recommended distance. For additional requirements check local codes.
 † Three feet above if within 10 feet horizontally.
 ‡ A vent shall not terminate directly above a sidewalk or paved driveway that is located between two single family dwellings and serves both dwellings.
 †† Permitted only if the veranda, balcony, porch, or deck is fully open on a minimum of two sides beneath the floor.
 †* Recommended to prevent recirculation of exhaust products. For additional requirements check local codes.

INSTALLATION

WALL AND CEILING PROTECTION

For optimum performance it is recommended that all horizontal runs have a minimum $\frac{1}{4}$ inch rise per foot using flexible venting.

For safe and proper operation of the fireplace, follow the venting instructions exactly.

HORIZONTAL TERMINATION: A clearance to combustibles of 2" must be maintained during the first 24" of venting when penetrating combustible walls. The firestop spacer (GD-500.106) supplied with the unit should be used to maintain this clearance. The first two feet of outer 7" diameter vent pipe, from the appliance must be wrapped in the 1 inch thick insulation sleeve (supplied) as well as having a 1 inch air gap. Thereafter a 1" clearance to combustibles may be maintained using firestop spacer (GD-500.96 for use with flexible venting or GD-500.136 for use with rigid venting).

VERTICAL TERMINATION: Only a clearance to combustibles of 1" all around the vent pipe is required.

HORIZONTAL INSTALLATION:

This application occurs when venting through an exterior wall.

FIGURES 2a-d. Having determined the air terminal location, cut and frame a hole in an exterior wall with a minimum square or round opening of $11\frac{1}{2}$ "*. (As an alternative to framing, a vent pipe shield may be installed, ensuring a 1" clearance to combustibles.

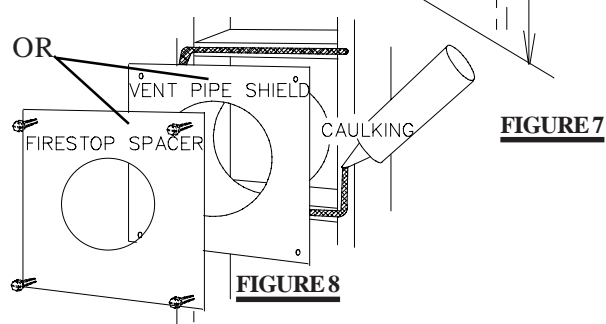

Mark and cut the vent pipe shield to the determined depth of the combustible wall. Apply a bead of caulking (not supplied) to the framework or to the shield plate (in the case of a finished wall) and secure the shield through the opening to the interior wall. The final location of the vent pipe shield should maintain the required clearance to the 7" vent pipe / liner. Do not fill this cavity with any type of material. Apply a bead of caulking all around and place a firestop spacer over the vent shield to restrict cold air from being drawn into the room or around the fireplace. Ensure that both spacer and shield maintain the required clearance to combustibles. Once the vent pipe / liner is installed in its final position, apply sealant between the pipe / liner and the firestop spacer.

VERTICAL INSTALLATION: This application occurs when venting through a roof. Installation kits for various roof pitches are available from your Napoleon dealer. See Accessories to order the specific kit required.

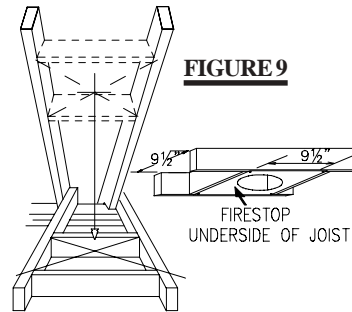

1. Determine the air terminal location, cut and frame $9\frac{1}{2}$ inch openings in the ceiling and the roof to provide the minimum clearance between the fireplace pipe / liner and any combustible material. Try to center the exhaust pipe location midway between two joist to prevent having to cut them. Use a plumb bob to line up the center of the openings.

DO NOT FILL THIS SPACE WITH ANY TYPE OF MATERIAL.

A vent pipe shield will prevent any materials such as insulation, from filling up the 1" air space around the pipe. Nail headers between the joist for extra support.

2. Apply a bead of caulking (not supplied) to the framework or to the Wolf Steel vent pipe shield plate or equivalent (in the case of a finished ceiling), and secure over the opening in the ceiling. A firestop must be placed on the bottom of each framed opening in a roof or ceiling that the venting system passes through. Apply a bead of caulking all around and place a firestop spacer over the vent shield to restrict cold air from being drawn into the room or around the fireplace. Ensure that both spacer and shield maintain the required clearance to combustibles. Once the vent pipe / liner is installed in its final position, apply sealant between the pipe / liner and the firestop spacer.

3. In the attic, after the pipe / liner has been installed, slide the vent pipe collar down to cover up the open end of the shield and tighten. This will prevent any materials, such as insulation, from filling up the 1" air space around the pipe.

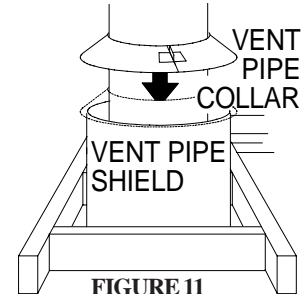

* The $11\frac{1}{2}$ inch framing dimension may be reduced to a $9\frac{1}{2}$ inch opening if the vent length, from the fireplace to the framed hole, is 24 inches or greater. If not, it is recommended to use a terminal extension plate, W500-0103, when mounting the air terminal.

USING FLEXIBLE VENT COMPONENTS



Use only approved aluminum flexible liner kits marked "Wolf Steel Approved Venting" as identified by the stamp only on the 7" outer liner. For optimum performance it is recommended that all horizontal runs have a minimum $\frac{1}{4}$ inch rise per foot using flexible venting.

For safe and proper operation of the fireplace, follow the venting instructions exactly.

HORIZONTAL AIR TERMINAL INSTALLATION

1. Stretch the 4" diameter aluminum flexible liner to the required length taking into account the additional length needed for the finished wall surface. Apply a heavy bead of the high temperature sealant, supplied with the unit, to the inside of the 4" liner approximately 1" from the end. Slip the liner a minimum of 2" over the fireplace vent collar and secure with 3 #8 screws.

2. Using the 7" diameter flexible aluminum liner, apply sealant, slide a minimum of 2" over the fireplace combustion air collar and secure with 3 #8 screws.

3. Insert the liners through the firestop. Position and secure the fireplace using the nailing tabs (2 per side) and/or secure to the floor using screws inserted through the two $\frac{1}{4}$ " diameter holes in the front left and right corners of the base. The liners should be flush with the exterior wall.

The air terminal may be recessed into the exterior wall or siding by $1\frac{1}{2}$ ", the depth of the return flange.

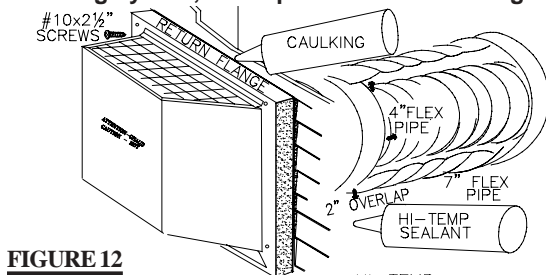

FIGURE 12

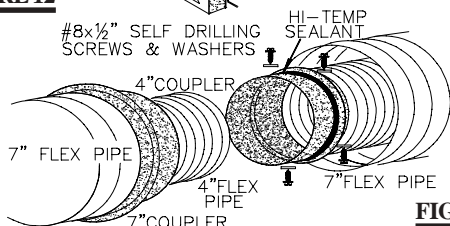

FIGURE 13

4. From outside, apply a bead of the high temperature sealant to the inside of both liners, approximately 1" from the end of each liner.

5. Holding the air terminal (lettering in an upright, readable position), insert into both liners with a twisting motion to ensure that both the terminal sleeves engage into the liners / sealant. Secure the terminal to the exterior wall and make weather tight by sealing with caulking (not supplied).

6. If more liner needs to be used to reach the fireplace, couple them together as illustrated in **FIGURE 13**. The vent system must be supported approximately every 3 feet for both vertical and horizontal runs. Use Napoleon support ring assembly **W010-0370** or equivalent noncombustible strapping to maintain the minimum 1" clearance to combustibles.

VERTICAL VENTING INSTALLATION

1. Fasten the roof support to the roof using the screws provided. The roof support is optional. In this case the venting is to be adequately supported using either an alternate method suitable to the authority having jurisdiction or the optional roof support.

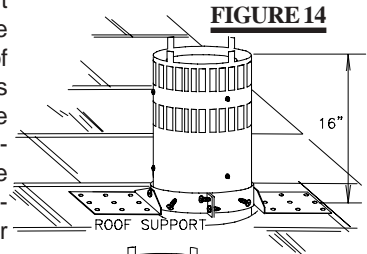

FIGURE 14

2. Stretch the 4" diameter aluminum flexible liner to the required length. Slip the liner a minimum of 2" over the inner sleeve of the air terminal and secure with 3 #8 screws. Seal using a heavy bead of the high temperature sealant.

3. Repeat using 7" diameter aluminum flexible liner.

4. Thread the air terminal pipe assembly down through the roof.

The air terminal must be located vertically and plumb. Attach the air terminal assembly to the roof support, ensuring that a minimum 16" of air terminal will penetrate the roof when fastened.

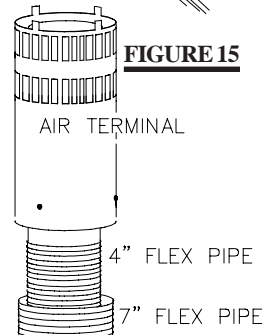

FIGURE 15

DO NOT CLAMP THE FLEXIBLE ALUMINUM LINER.

5. Remove nails from the shingles, above and to the sides of the chimney. Place the flashing over the air terminal and slide it underneath the sides and upper edge of the shingles. Ensure that the air terminal is properly centered within the flashing, giving a $\frac{3}{4}$ " margin all around. Fasten to the roof. Do **not** nail through the lower portion of the flashing. Make weather-tight by sealing with caulking. Where possible, cover the sides and top edges of the flashing with roofing material.

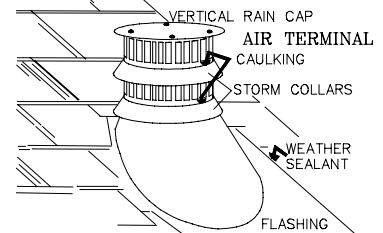

FIGURE 16

6. Apply a heavy bead of weatherproof caulking 2 inches above the flashing. Slide the storm collar around the air terminal and down to the caulking. Tighten to ensure that a weather-tight seal between the air terminal and the collar is achieved. Attach the other storm collar centered between the air intake and the air exhaust slots onto the air terminal. Tighten securely. Attach the vertical rain cap.

Spacers are attached to the 4" inner flex liner at predetermined intervals to maintain a 1-1/4" air gap to the 7" outer liner. These spacers must not be removed.

7. If more liner needs to be used to reach the fireplace, couple them together as illustrated in **FIGURE 13**. The vent system must be supported approximately every 3 feet for both vertical and horizontal runs. Use Wolf Steel support ring assembly **W010-0370** or equivalent noncombustible strapping to maintain a clearance to combustibles of 1".

10 FIREPLACE VENT CONNECTION

1. Install the 4 inch diameter aluminum flexible liner to the fireplace. Secure with 3 screws and flat washers. Seal the joint and screw holes using the high temperature sealant provided.
2. Install the 7 inch diameter aluminum flexible liner to the fireplace. Attach and seal the joints.

FIGURE 17

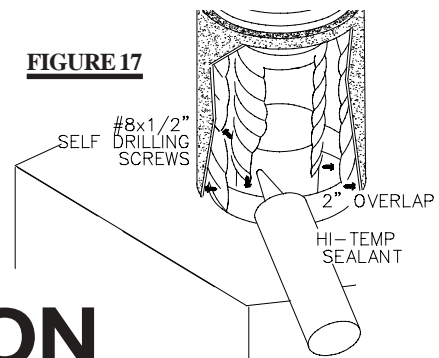

INSTALLATION USING RIGID VENT COMPONENTS

For optimum performance it is recommended that all horizontal runs have a 1/4 inch rise per foot.

For safe and proper operation of the fireplace, follow the venting instructions exactly.

The vent system must be supported approximately every 3 feet for both vertical and horizontal runs. Use Napoleon vent spacers **W615-0033** or equivalent every 3 feet and on either side of each elbow to maintain the minimum 1 1/4" clearance between the outer and inner vent pipes. Use Napoleon support ring assembly **W010-0370** or equivalent noncombustible strapping to maintain the minimum 1" clearance to combustibles for both vertical and horizontal runs.

HORIZONTAL AIR TERMINAL INSTALLATION

1. Move the fireplace into position. Measure the vent length required between terminal and fireplace taking into account the additional length needed for the finished wall surface and any 1 1/4" overlaps between venting components.
2. Apply high temperature sealant to the outer edge of the 4" inner collar of the fireplace. Attach the first vent component and secure using 3 self tapping screws. Repeat using 7" piping.
3. Holding the air terminal (lettering in an upright, readable position), insert into both vent pipes with a twisting motion to ensure that both the terminal sleeves engage into the vent pipes and the sealant. Secure the terminal to the exterior wall and make weather tight by sealing with caulking (not supplied). **The air terminal may be recessed into the exterior wall or siding by 1 1/2", the depth of the return flange.**

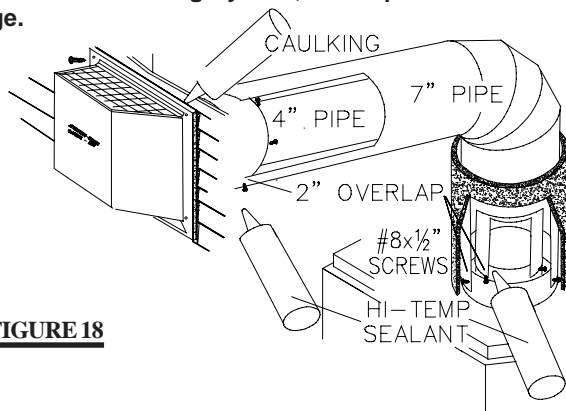

FIGURE 18

VERTICAL VENTING INSTALLATION

1. Move the fireplace into position.
2. Fasten the roof support to the roof using the screws provided. **FIGURE 15.** The roof support is optional. In this case the venting is to be adequately supported using either an alternate method suitable to the authority having jurisdiction or the optional roof support.
3. Apply high temperature sealant to the outer edge of the inner sleeve of the air terminal. Slip a 4" diameter coupler a minimum of 2" over the sleeve and secure using 3 screws.

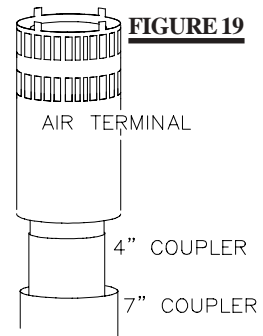

FIGURE 19

4. Apply high temperature sealant to the outer edge of the of the outside sleeve of the air terminal. Slip a 7" diameter coupler over the sleeve and secure as before. **FIGURE 20.** Trim the 7" coupler even with the 4" coupler end.
5. Thread the air terminal pipe assembly down through the roof support and attach, ensuring that a minimum 16" of air terminal will penetrate the roof when fastened. **FIGURE 17.** If the attic space is tight, we recommend **threading the Wolf Steel vent pipe collar or equivalent loosely onto the air terminal assembly as it is passed through the attic.** **FIGURE 12.** The air terminal must be located vertically and plumb.

6. Remove nails from the shingles, above and to the sides of the chimney. Place the flashing over the air terminal and slide it underneath the sides and upper edge of the shingles. Ensure that the air terminal is properly centered within the flashing, giving a 3/4" margin all around. Fasten to the roof. Do NOT nail through the lower portion of the flashing. Make weather-tight by sealing with caulking. Where possible, cover the sides and top edges of the flashing with roofing material.

7. Apply a heavy bead of waterproof caulking 2 inches above the flashing. Slide the storm collar around the air terminal and down to the caulking. Tighten to ensure that a weather-tight seal between the air terminal and the collar is achieved. Attach the other storm collar centered between the air intake and air exhaust slots onto the air terminal. Tighten securely. Attach the rain cap.

8. Continue adding rigid venting sections, sealing and securing as above. Attach a 4" collapsed telescopic pipe to the last section of rigid piping. Secure with screws and seal. Repeat using a 7" telescopic pipe.

9. Run a bead of high temperature sealant around the outside of the 4" elbow. Pull the adjustable pipe a minimum 2" onto the elbow. Secure with 3 screws. Repeat with the 7" telescopic pipe.

10. In the attic, slide the vent pipe collar down to cover up the open end of the shield and tighten. This will prevent any materials, such as insulation, from filling up the 1" air space around the pipe.

GAS INSTALLATION

Proceed once the vent installation is complete.

1. Route a 3/8" N.P.T. black iron gas line, 1/2" type-L copper tubing or equivalent to the fireplace.

2. For ease of accessibility, an optional remote wall switch or millivolt thermostat may be installed in a convenient location. Route 2 strand (solid core) millivolt wire through the electrical hole located at the bottom left side of the unit. The recommended maximum lead length depends on wire size:

WIRE SIZE	MAX. LENGTH
14 gauge	100 feet
16 gauge	60 feet
18 gauge	40 feet

Attach the two leads to terminals 1 and 3 located on the gas valve.

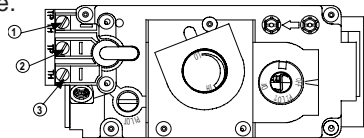

FIGURE 20

Do not connect either the wall switch, thermostat or gas valve to electricity (110 volts).

3. Install rigid black pipe, 1/2" type-L copper tubing or, if local codes permit, a 3/8" flex connector and shutoff valve to the gas line and the fireplace gas valve. Seal and tighten securely. An adapter fitting is required between the gas valve and the copper tubing or flex connector. **DO NOT KINK THE FLEXIBLE CONNECTOR.**

4. Check for gas leaks by brushing on a soap and water solution. **DO NOT USE OPEN FLAME.**

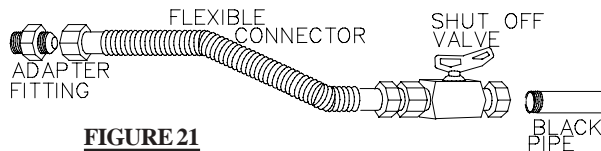

FIGURE 21

Purge all gas lines with the glass door of the fireplace open. Assure that a continuous gas flow is at the burner before closing the door.

MOBILE HOME INSTALLATION

The fireplace is equipped with two 1/4" diameter holes located in the front left and right corners of the base. For mobile home installations, the fireplace must be fastened in place. Use #10 screws, inserted through the holes in the base to secure. It is recommended that the fireplace be secured in all installations.

FRAMING

It is best to frame your fireplace after it is positioned and the vent system is installed. Use 2x4's and frame to local building codes. To install the fireplace face flush with the finished wall, position the framework to accommodate the thickness of the finished wall.

MAINTAIN THESE MINIMUM CLEARANCES TO COMBUSTIBLES:

Fireplace framing - 0" to stand-offs (top, rear & sides)
 Fireplace finishing - 3" to sides, 7 1/4" to top of unit

Non-combustible material (brick, stone or ceramic tile) may protrude over the black painted surface of the fireplace front and is required for use in conjunction with the GD425 kit. This kit is designed to accommodate a noncombustible material to a maximum finished thickness of 3/4". **SEE FIGURE 26.**

FIGURE 22: Framing Requirements

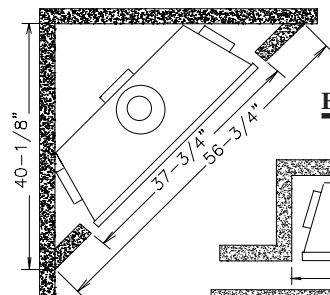
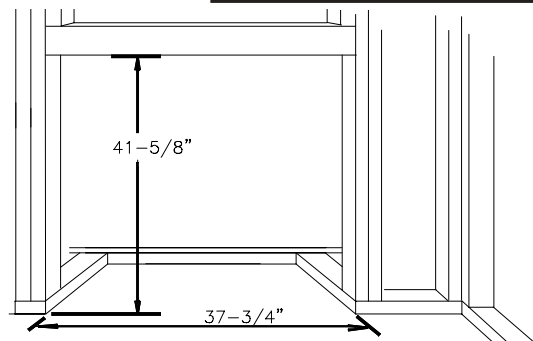

FIGURE 23

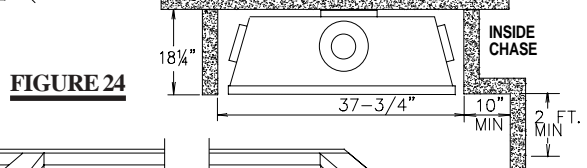

FIGURE 24

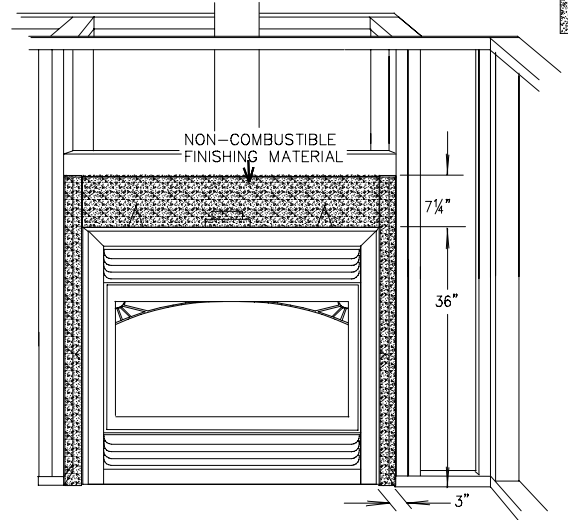
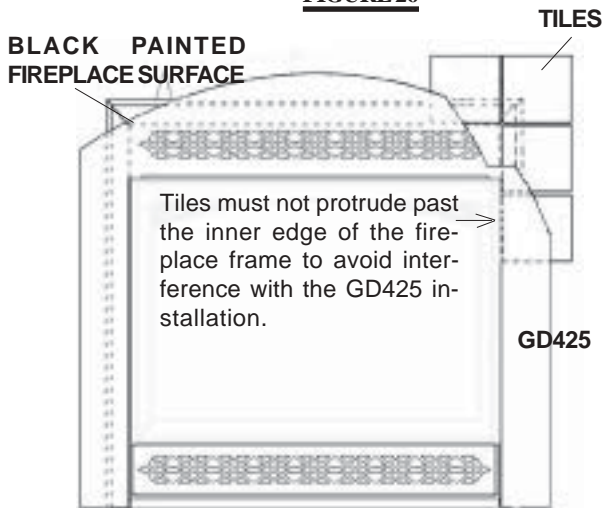

FIGURE 25: FINISHING REQUIREMENTS

FIGURE 26



*** When using the optional ornamental fascia and panels, the minimum height from the top of the unit to the mantle is 7".**

**** A steel stud header is recommended, however traditional combustible header material may be used.**

Note: In order to avoid the possibility of exposed insulation or vapour barrier coming in contact with the fireplace body, it is recommended that the walls of the fireplace enclosure be "finished" (ie: drywall/sheetrock), as you would finish any other outside wall of a home. This will ensure that clearance to combustibles is maintained within the cavity.

It is not necessary to install a hearth extension, but the fireplace should be raised up to be flush with either the hearth or the finished floor. Objects placed in front of the fireplace should be kept a minimum of 48" away from the front face.

Combustible mantle clearance can vary according to the mantle depth. Use the graph to help evaluate the clearance needed.

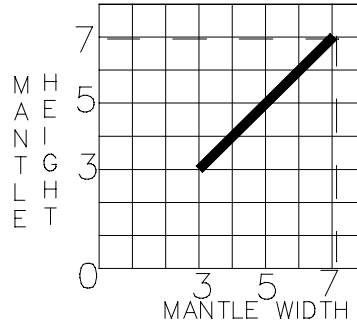

FIGURE 27

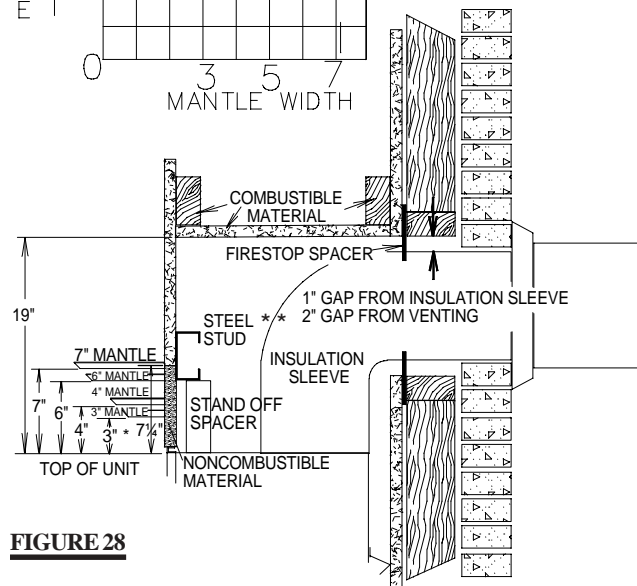

FIGURE 28

FINISHING

DOOR INSTALLATION

Loosely thread a screw provided with the door kit into the top hole on the left side of the firebox. Hang the door by the hinge onto the screw. Insert the remaining 4 screws and tighten.

IMPORTANT: Ensure screws are driven in straight or the hole thread may be damaged.

FIGURE 29a

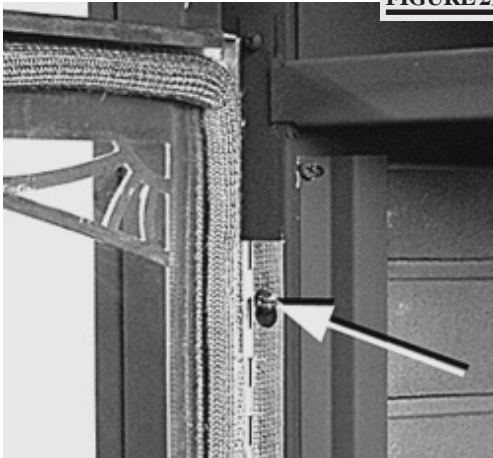

DOOR CLOSING AND OPENING

Open the valve control door. Hook the top and bottom door latches, located at the right side of the door into the corresponding slots in the door.

FIGURE 29b



The door latch holes are elongated for door levelling. To level the door, it may need to be lifted up at the right side before latching to ensure the door is level.

Prior to opening the door, lift up and remove the upper louvres or ornamental insets.

OPTIONAL LOUVRE INSTALLATION:

Remove the protective plastic wrap from the louvres and install as illustrated. Clip each upper louvre into a slot on the louvre bracket. Ensure that the louvres are centered within the opening.

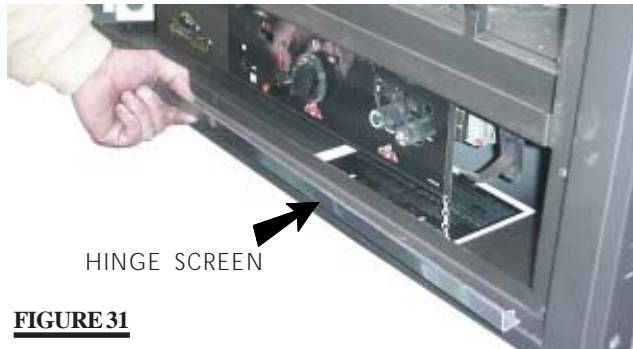
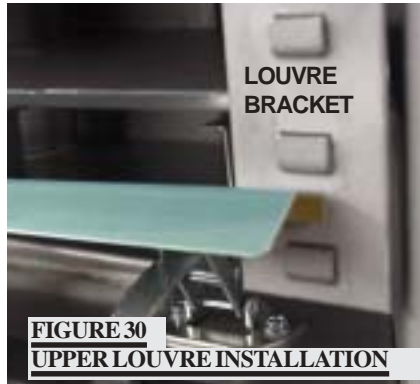

Remove the hinge screen, if factory installed.



Screw the lower louvre assembly to the lip of the fireplace base as shown. Install hinge screen.

OPTIONAL ORNAMENTAL INSET INSTALLATION:

Hook the top panel onto the fireplace as shown using the slots on both sides of the unit.



Attach the hinges to the lower ornamental panel using the nuts, washers and bolts supplied. Secure the lower panel assembly to the unit using the four flat head thread cutting screws supplied. To install the lower ornamental panel, it will be necessary to remove the hinge screen if the fireplace is so equipped. See Figure 31.



14 FACE PLATE INSTALLATION:

Attach a screw and spacer as illustrated to either side at the top and bottom of the corner posts.



FIGURES 34 a - c

Lift up and hook the fascia over the 4 screw and spacer assemblies.

LOG PLACEMENT:

PHAZER™ logs and glowing embers, exclusive to Napoleon Fireplaces, provide a unique and realistic glowing effect that is different in every installation. Take the time to carefully position the glowing embers for a maximum glowing effect.

FIGURES 35

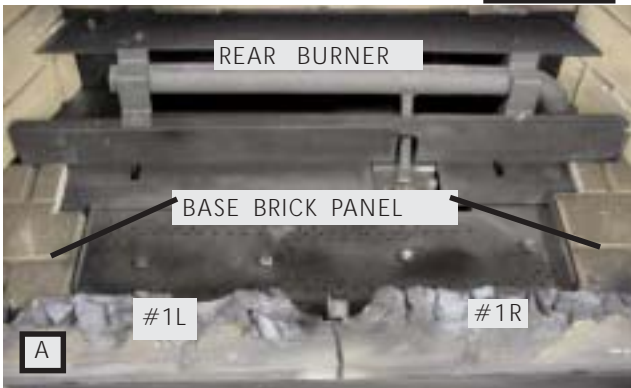

A Place the two charcoal strips (#1), as shown centered along the inside front edge of the burner tray. Position a base brick panel to either side of the burner.



B Place the back log onto the log tray, between the left and right base brick panels and in front of the rear burner.



C Position log #3 to the right of the firebox using the two locating studs. Log #4 is located using the stud on the narrow end as well as a notch which will nest onto the second grate post from the left. Position log #5 to the left side of the firebox using a single locating stud.



D Place the bottom of log #6 against the left outermost grate post and onto the notch of the rear log (#2). Log #7 is set into the center grate post and the top into the pocket provided on log #6.



E Log #8 is positioned against the right outermost grate post and the lower notch located on log #7.

The lower end of log #9 is set into the rear left corner and against the top notch provided on log #7.

Tear the embers into pieces and place along the front row of burner ports as well as along the carry-over ports located in the center of the burner and running from the front to the back. Care should be taken to shred the embers into thin, small irregular pieces as only the exposed edges of the fibre hairs will glow. **The ember material will only glow when exposed to direct flame; however, care should be taken to not block the burner ports.**

Log colours may vary. During the initial use of the fireplace, the colours will become more uniform as colour pigments burn in during the heat activated curing process.

Positioning the logs improperly will cause flame impingement and carboning.

Blocked burner ports can cause an incorrect flame pattern, carbon deposits and delayed ignition. **PHAZER™** logs glow when exposed to direct flame. Use only certified "glowing embers" and **PHAZER™** logs available from your Napoleon dealer.

OPTIONAL BLOWER INSTALLATION

INSTALLATION TO BE DONE BY A QUALIFIED INSTALLER and must be electrically connected and grounded in accordance with local codes. In the absence of local codes, use the current CSA C22.1 CANADIAN ELECTRICAL CODE in Canada or the ANSI/NFPA 70-1996 NATIONAL ELECTRICAL CODE in the United States.

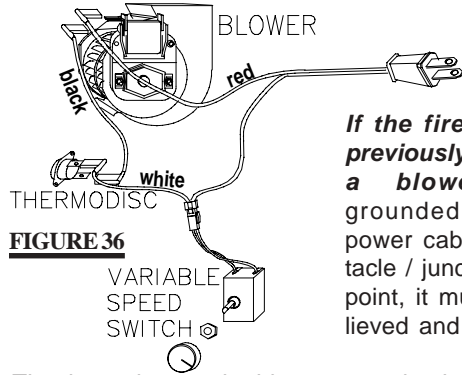

FIGURE 36

If the fireplace was not previously equipped with a blower: route a grounded 2-wire, 60hz power cable to the receptacle / junction box. At this point, it must be strain relieved and insulated.

The three slots on the blower mounting bracket allow ease of adjustment when attaching the blower. For a quiet running blower, do not allow the assembly to sit on the firebox base.

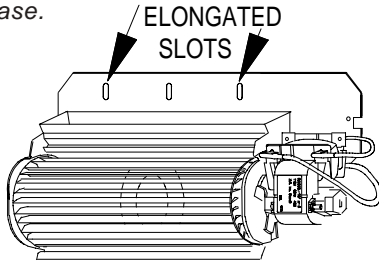

FIGURE 37

Slide the vibration reducing pad (A) into the clip (C) and up against the threaded stud (B) at the other end. The blower must be able to be positioned entirely onto the pad.

Tilt the blower onto its side. Slide it past the controls and into the clip (C). Secure to the threaded stud using the lock washer and wing nut provided. Ensure that the blower does not touch the fireplace base or the firebox.

Attach the connectors from the black and white wires to the thermodisc and secure the thermodisc bracket to the securing stud at the bottom left of the unit using a lock washer and wing nut. Ensure that the thermodisc touches the firebox wall.

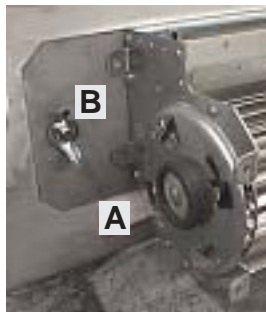

FIGURE 38



FIGURE 39

Attach the connectors from the black and red wires to the blower.

Attach and secure the variable speed switch using the nut provided. Plug the harness cord into the receptacle.

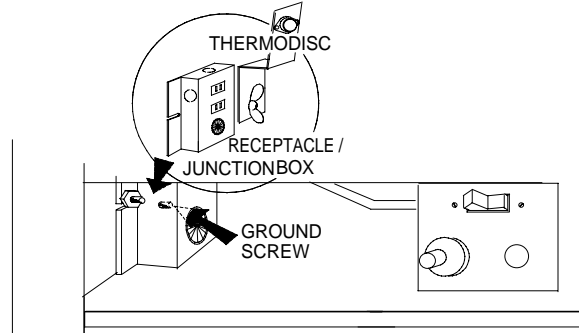

FIGURE 40

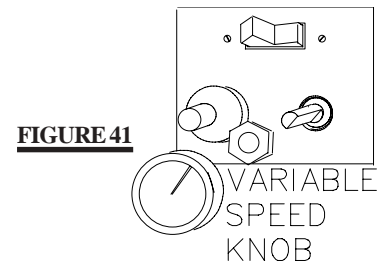

FIGURE 41

The wire harness provided in this kit is a universal harness. When installed, ensure that any excess wire is contained, preventing it from making contact with any moving or hot objects.

Because the blower is thermally activated, when turned on, it will automatically start approximately 10 minutes after lighting the fireplace and will run for approximately 30-45 minutes after the fireplace has been turned off. Use of the fan increases the output of heat.

Drywall dust will penetrate into the blower bearings, causing irreparable damage. Care must be taken to prevent drywall dust from coming into contact with the blower or its compartment. Any damage resulting from this condition is not covered by the warranty policy.

OPTIONAL FAN INSTALLATION

ELECTRICAL INSTALLATION TO BE DONE BY A QUALIFIED INSTALLER and must be connected and grounded in accordance with local codes. In the absence of local codes, use the current CSA C22.1 CANADIAN ELECTRICAL CODE in Canada or the ANSI/NFPA 70-1990 NATIONAL ELECTRICAL CODE in the United States.

If the fireplace was not previously equipped with a fan: route a grounded 2-wire, 60hz power cable to the junction box. At this point, it must be strain relieved and insulated. The wire harness provided in this kit is a universal harness. When installed, ensure that any excess wire is contained, preventing it from making contact with moving or hot objects.

Position the vibration reducing pad into the clip and onto the threaded stud at the other end, piercing a hole into the pad. The fan assembly must be able to be positioned entirely onto the pad.

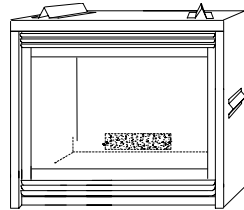

FIGURE 42

Slide the fan assembly past the controls and into the clip. Secure using the lock washer and nut provided. Plug the harness cord into the receptacle.

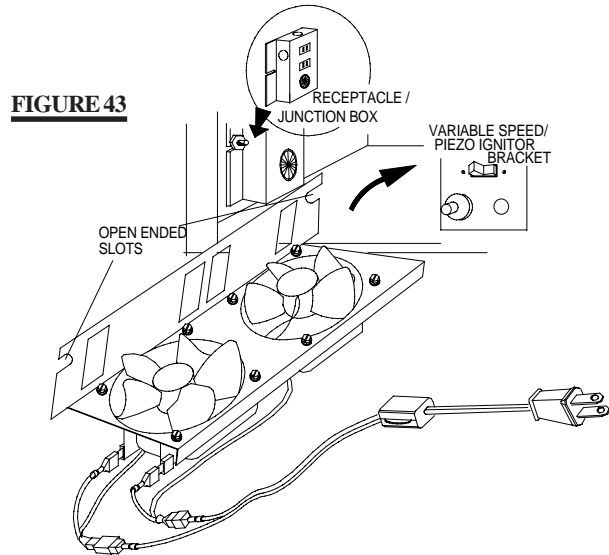

FIGURE 43

GD36 THERMOSTATIC SENSOR CONTROL

This optional kit is meant to be used only in conjunction with the GD65 Fan Kit, shown above, which may be ordered from your Wolf Steel / Napoleon dealer.

With the thermostatic sensor option, the fan, when turned on, becomes thermally activated, and will automatically run approximately 15-30 minutes after the fireplace has been lit and for approximately 30-45 minutes after the fireplace has been turned off. Use of the fan increases the output of heat.

Unplug the harness cord from the receptacle. Connect all wires as shown.

Attach and secure the sensor assembly bracket to the securing stud located next to the receptacle/junction box at the bottom left of the unit using the lock washer and wing nut. Ensure that the thermodisc touches the firebox wall. Plug the harness cord back into the receptacle. When installed, ensure that any excess wire is contained, preventing it from making contact with moving or hot objects.

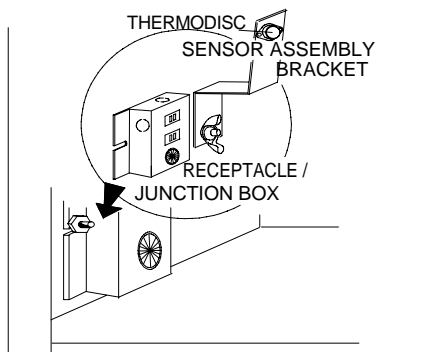

FIGURE 44

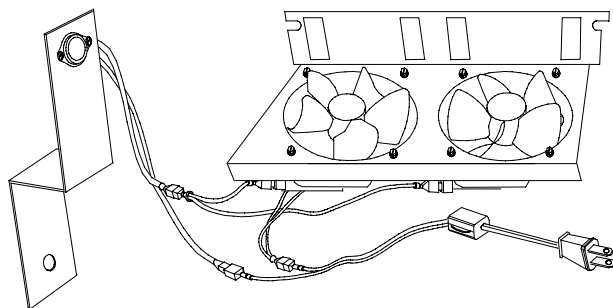

FIGURE 45

OPERATION / MAINTENANCE

OPERATING INSTRUCTIONS

When lit for the first time, the fireplace will emit a slight odour for a few hours. This is a normal temporary condition caused by the curing of the logs and the "burn-in" of internal paints and lubricants used in the manufacturing process and will not occur again. Simply open a window to sufficiently ventilate the room.

After extended periods of non-operation such as following a vacation or a warm weather season, the fireplace may emit a slight odour for a few hours. This is caused by dust particles in the heat exchanger burning off. Open a window to sufficiently ventilate the room.

PURGE ALL GAS LINES WITH THE GLASS DOOR OF THE FIREPLACE **OPEN**. ASSURE THAT A CONTINUOUS GAS FLOW IS AT THE BURNER BEFORE **CLOSING** THE DOOR.

FOR YOUR SAFETY READ BEFORE OPERATING

- A.** This fireplace is equipped with a pilot which must be lit by hand while following these instructions exactly.
- B.** Before operating smell all around the fireplace area for gas and next to the floor because some gas is heavier than air and will settle on the floor.

WHAT TO DO IF YOU SMELL GAS:

- Turn off all gas to the fireplace.
- Open windows.
- Do not try to light any appliance.
- Do not touch any electric switch; do not use any phone in your building.





- Immediately call your gas supplier from a neighbour's phone. Follow the gas supplier's instructions.
 - If you cannot reach your gas supplier, call the fire department.
- C.** Use only your hand to turn the gas control knob. Never use tools. If the knob will not turn by hand, do not try to repair it. Call a qualified service technician. Force or attempted repair may result in a fire or explosion.
- D.** Do not use this fireplace if any part has been under water. Immediately call a qualified service technician to inspect the fireplace and replace any part of the control system and any gas control which has been under water.

LIGHTING INSTRUCTIONS

WARNING: The gas valve has an interlock device which will not allow the pilot burner to be lit until the thermocouple has cooled. Allow approximately 60 seconds for the thermocouple to cool.



When lighting and re-lighting, the gas knob cannot be turned from pilot to off unless the knob is **depressed slightly**.

1. Stop! Read the above safety information on this label.
2. Turn off all electric power to the fireplace.
3. Turn the gas knob clockwise  to off.
4. Wait five (5) minutes to clear out any gas. If you smell gas including near the floor. Stop! Follow "B" in the above safety information on this label. If you don't smell gas go the next step.

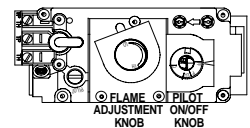
5. Turn gas knob counter-clockwise  to pilot.
6. Depress slightly and hold gas knob while lighting the pilot with the push button ignitor. Keep knob depressed for one minute, then release. If pilot does not continue to burn, repeat steps 3 through 5.
7. With pilot lit, depress and turn gas knob counter-clockwise  to on.
8. If equipped with remote on-off switch/thermostat, main burner may not come on when you turn valve to on. Remote switch must be in the on position to ignite burner.
9. Turn on all electric power to the fireplace.



TO TURN OFF GAS

1. Turn off all electric power to the fireplace if service is to be performed.
2. For a complete shut-down procedure: push in gas control knob slightly and turn clockwise  to off. Do not force.
3. For a temporary shut-down procedure: set thermostat to lowest setting or remote switch to off. Press and turn the gas knob clockwise  to pilot.

18 MAINTENANCE

TURN OFF THE GAS AND ELECTRICAL POWER BEFORE SERVICING THE FIREPLACE.

CAUTION: Label all wires prior to disconnection when servicing controls. Wiring errors can cause improper and dangerous operation. Verify proper operation after servicing. This fireplace and its venting system should be inspected before use and at least annually by a qualified service person. The fireplace area must be kept clear and free of combustible materials, gasoline or other flammable vapours and liquids. The flow of combustion and ventilation air must not be obstructed.

1. In order to properly clean the burner and pilot assembly, remove the logs to expose both assemblies.
2. Keep the control compartment, logs, burner, air shutter opening and the area surrounding the logs clean by vacuuming or brushing, *at least once a year*.

3. Check to see that all burner ports are burning. Clean out any of the ports which may not be burning or are not burning properly. (right brick panel must be removed in order to facilitate burner removal, where applicable.)
4. Check to see that the pilot flame is large enough to engulf the thermocouple and thermopile and reaches toward the burner with the third jet.
5. Replace the cleaned logs.
6. Check to see that the main burner ignites completely on all openings when the gas knob for the burner is turned on. A 5 to 10 second total light-up period is satisfactory. If ignition takes longer, consult your Napoleon dealer / distributor.
7. Check that the gasketing on the sides, top and bottom of the door is not broken or missing. Replace if necessary.

ADJUSTMENTS

PILOT BURNER ADJUSTMENT

Adjust the pilot screw to provide properly sized flame. Turn in a clockwise direction to reduce the gas flow.

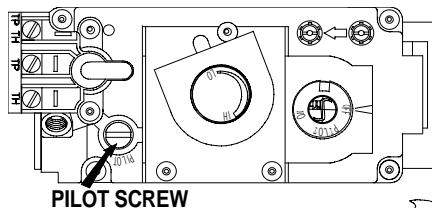

FIGURE 46

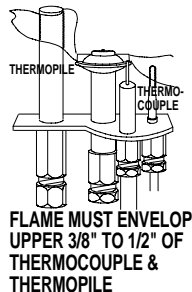

FIGURE 47

VENTURI ADJUSTMENT

Air Shutter Openings	Front (inches)	Back (inches)
LP	1/4" (0.250)	3/8" (0.375)
NG	3/16" (0.188)	5/16" (0.313)

Closing the air shutter will cause a more yellow flame, but can lead to carboning. Opening the air shutter will cause a more blue flame, but can cause flame lifting from the burner ports. The flame may not appear yellow immediately; allow 15 to 30 minutes for the final flame colour to be established.

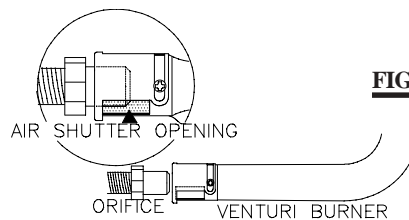

FIGURE 48

AIR SHUTTER ADJUSTMENT MUST ONLY BE DONE BY A QUALIFIED GAS INSTALLER!

REPLACEMENTS

ORDERING REPLACEMENT PARTS

Contact your dealer or the factory for questions concerning prices and policies on replacement parts. Normally all parts can be ordered through your Napoleon dealer or distributor. When ordering replacement parts always give the following information:

1. **Model & Serial Number** of the unit.
2. **Installation date** of the unit.
3. **Part Number**
4. **Part Description**
5. **Finish**

REPLACEMENT PARTS For warranty replacement parts, a photocopy of the original invoice will be required to honour the claim.

PART NO.	DESCRIPTION
GL-625	LOG SET ASSEMBLY
W135-0091L	#1L CHARCOAL STRIP
W135-0091R	#1R CHARCOAL STRIP
W135-0083	#2 LOG
W135-0089	#3 LOG
W135-0090	#4 LOG
W135-0088	#5 LOG
W135-0087	#6 LOG
W135-0085	#7 LOG
W135-0086	#8 LOG
W135-0084	#9 LOG
W361-0016	GLOWING EMBERS
W475-0190	LEFT BASE BRICK PANEL
W475-0191	RIGHT BASE BRICK PANEL
W390-0002	DOOR LATCH (EA)
W725-0035	NATURAL GAS VALVE
W725-0034	PROPANE GAS VALVE
W380-0001	REAR BURNER CONTROL KNOB
W380-0010	PILOT ON/OFF KNOB EXTENSION
W380-0009	FLAME ADJUSTMENT KNOB EXTENSION
W573-0008	HIGH TEMPERATURE SEALANT
W455-0021	#45 NATURAL GAS ORIFICE - FRONT
W455-0048	#47 NATURAL GAS ORIFICE - REAR
W455-0050	#55 PROPANE GAS ORIFICE - FRONT
W455-0060	#57 PROPANE GAS ORIFICE - REAR
W357-0001	PIEZO IGNITER
W680-0005	THERMOCOUPLE
W240-0005	ELECTRODE c/w LEAD
W680-0004	THERMOPILE
W010-0796	NATURAL GAS PILOT ASSEMBLY (TOP CONVERTIBLE)
W010-0797	PROPANE GAS PILOT ASSEMBLY (TOP CONVERTIBLE)
W455-0070	NG PILOT ORIFICE (TOP CONVERTIBLE)
W455-0068	LP PILOT ORIFICE (TOP CONVERTIBLE)
W385-0033	NAPOLEON LOGO
W660-0005	BURNER ON/OFF SWITCH
W361-0027	INSULATION SLEEVE
W010-0621	GLASS c/w GASKET
W562-0009	DOOR GASKET (100 INCHES)
W500-0106	FIRESTOP (2 INCH CLEARANCE)
W100-0065	REAR TUBE BURNER
W010-0728	PAN BURNER

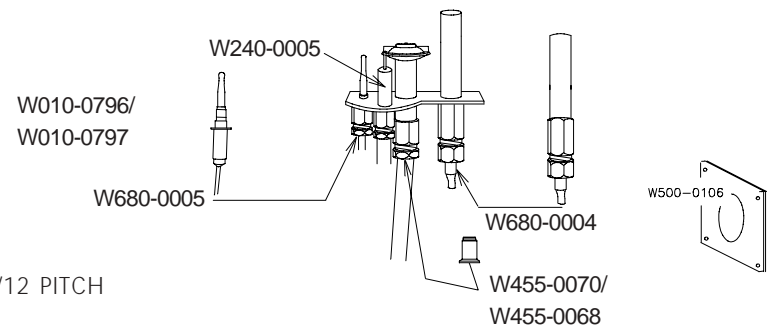
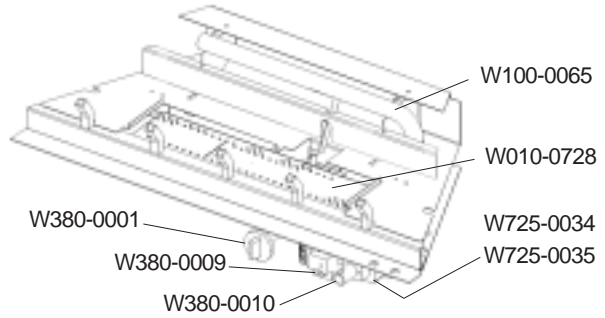
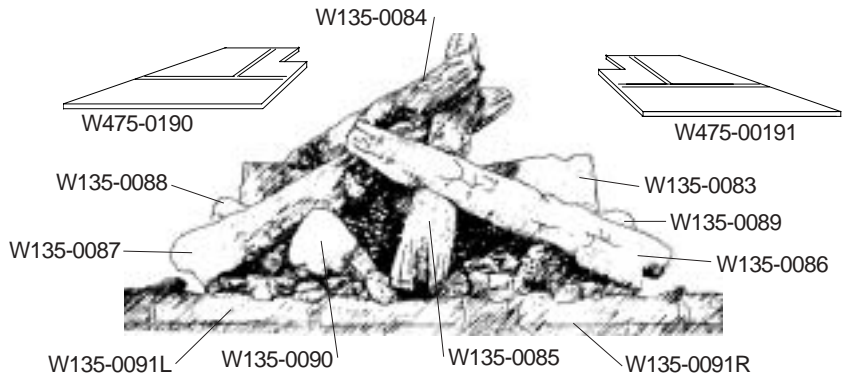

TERMINAL KITS

GD-110	- ROOF TERMINAL KIT - 1/12 TO 7/12 PITCH
W120-0036	VERTICAL CAP
W010-0569	AIR TERMINAL
W010-0567	ROOF SUPPORT
W170-0063	STORM COLLAR
W263-0054	ROOF FLASHING
GD-111	- ROOF TERMINAL KIT - 8/12 TO 12/12 PITCH
W120-0036	VERTICAL CAP
W010-0569	AIR TERMINAL
W010-0567	ROOF SUPPORT
W170-0063	STORM COLLAR
W263-0055	ROOF FLASHING
GD-112	- ROOF TERMINAL KIT - FLAT ROOF
W120-0036	VERTICAL CAP
W010-0569	AIR TERMINAL
W010-0567	ROOF SUPPORT
W170-0063	STORM COLLAR
W263-0056	ROOF FLASHING
GD-201	- PERISCOPE
GD-222	- WALL TERMINAL KIT

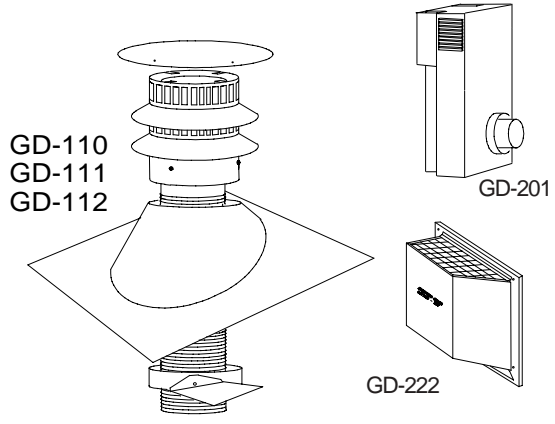

20 VENT KITS

GD-220 (5 FOOT)

- W010-0397 4" FLEXIBLE ALUMINUM LINER c/w SPACERS
- W410-0017 7" FLEXIBLE ALUMINUM LINER

GD-330 (10 FOOT)

- W010-0300 4" FLEXIBLE ALUMINUM LINER c/w SPACERS
- W410-0018 7" FLEXIBLE ALUMINUM LINER
- W010-0370 WALL SUPPORT ASSEMBLY

ACCESSORIES

PART NO.	DESCRIPTION
W500-0096	FIRE STOP - FLEXIBLE VENTING
W500-0136	FIRESTOP - RIGID VENTING
W500-0103	TERMINAL EXTENSION PLATE
W573-0008	HI-TEMP SEALANT
GD101	WINDSHIELD KIT
GD301	HEAT GUARD
GD303	VINYL SIDING SHIELD
GD3TR-PB	3" TRIM KIT - POLISHED BRASS
GD3TR-SS	3" TRIM KIT - STAINLESS STEEL
GD4TR-PB	4" - 3D TRIM KIT - POLISHED BRASS
GD4TR-SS	4" - 3D TRIM KIT - STAINLESS STEEL
W010-0370	WALL SUPPORT ASSEMBLY
W175-0001	4" COUPLER
W175-0013	7" COUPLER
W175-0140	CONVERSION KIT - NG TO LP
W175-0167	CONVERSION KIT - LP TO NG
W175-0168	CONVERSION KIT - NG TO LP (TOP CONVERTIBLE)
W175-0169	CONVERSION KIT - LP TO NG (TOP CONVERTIBLE)
GD825-N	MODULATING REGULATOR NG
GD825-P	MODULATING REGULATOR LP
W660-0013	MODULATING REMOTE
W660-0002	HAND HELD WIRELESS REMOTE SWITCH
W660-0011B	REMOTE CONTROL - ADVANTAGE PLUS
W660-0010B	REMOTE CONTROL - ADVANTAGE
GD-785KT	DECORATIVE BRICK PANEL KIT
GDLVPB	UPPER & LOWER LOUVRE KIT - POLISHED BRASS
GDLVSS	UPPER & LOWER LOUVRE KIT - STAINLESS STEEL
GDLVK	UPPER & LOWER LOUVRE KIT - BLACK
GDLVG	UPPER & LOWER LOUVRE KIT - GOLD
GZ550-1KT	BLOWER KIT
GD65	FAN KIT
GD36	THERMOSTATIC SENSOR CONTROL FOR USE ONLY WITH Gd65
KB35	VARIABLE SPEED SWITCH
W500-0033	V.S.S. MOUNTING PLATE FOR WALL SWITCH
W690-0001	MILLIVOLT THERMOSTAT

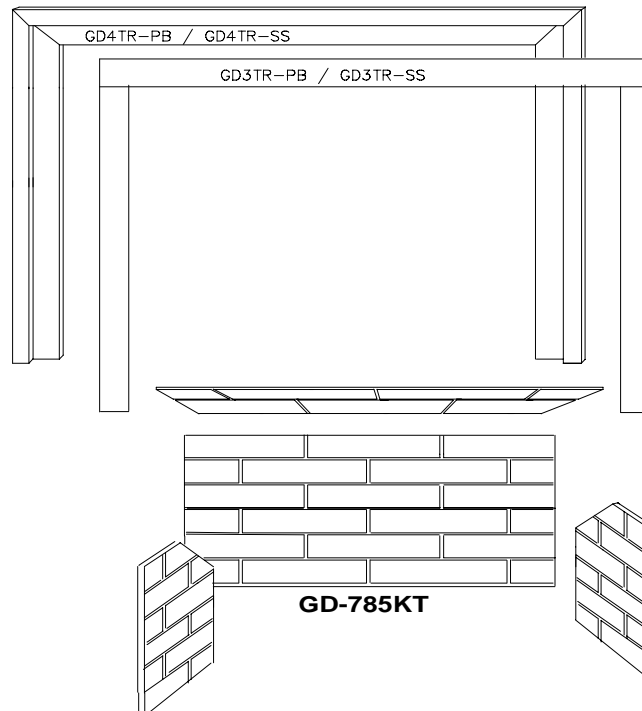
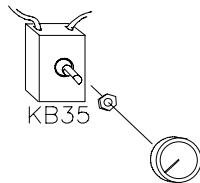
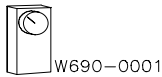
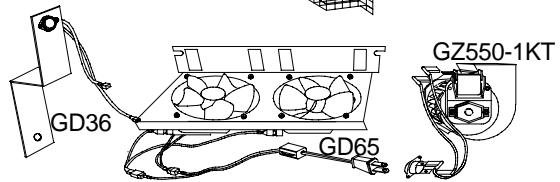
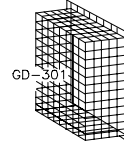
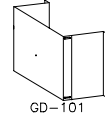
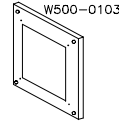
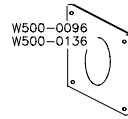

ACCESSORIES - CONTINUED

- GD425-K FACE PLATE FOR MARBLE OR TILE - BLACK
- GD426-K FACE PLATE FOR FLUSH FACING - BLACK
- GD425-BG FACE PLATE FOR MARBLE OR TILE - BRUSHED GOLD
- GD426-BG FACE PLATE FOR FLUSH FACING - BRUSHED GOLD
- GD425-G FACE PLATE FOR MARBLE OR TILE - GOLD
- GD426-G FACE PLATE FOR FLUSH FACING - GOLD
- GA427 REVERSIBLE BLACK / POLISHED BRASS INLAY
- GDOIK ORNAMENTAL INSET - BLACK (TOP & BOTTOM)
- GDOIG ORNAMENTAL INSET - GOLD (TOP & BOTTOM)
- GDOIBG ORNAMENTAL INSET - BRUSHED GOLD (TOP & BOTTOM)
- GDOISS ORNAMENTAL INSET - STAINLESS STEEL (TOP & BOTTOM)
- GD70B-KT BAY FRONT C/W PULL SCREEN
- 70BGL BAY GLASS (OPTIONAL)
- GDBOIK BAY ORNAMENTAL INSET, UPPER & LOWER - BLACK (TOP & BOTTOM)
- GDBOIG BAY ORNAMENTAL INSET, UPPER & LOWER - GOLD PLATED (TOP & BOTTOM)
- GDBOIKG BAY ORNAMENTAL INSET, UPPER & LOWER - BLACK GOLD (TOP & BOTTOM)
- GDBLK BAY LOUVRE KIT, UPPER & LOWER - BLACK (TOP & BOTTOM)
- GDBLPB BAY LOUVRE KIT, UPPER & LOWER - POLISHED BRASS (TOP & BOTTOM)
- GDBLSS BAY LOUVRE KIT, UPPER & LOWER - STAINLESS STEEL (TOP & BOTTOM)
- D70K BLACK DOOR
- D70G GOLD PLATED DOOR

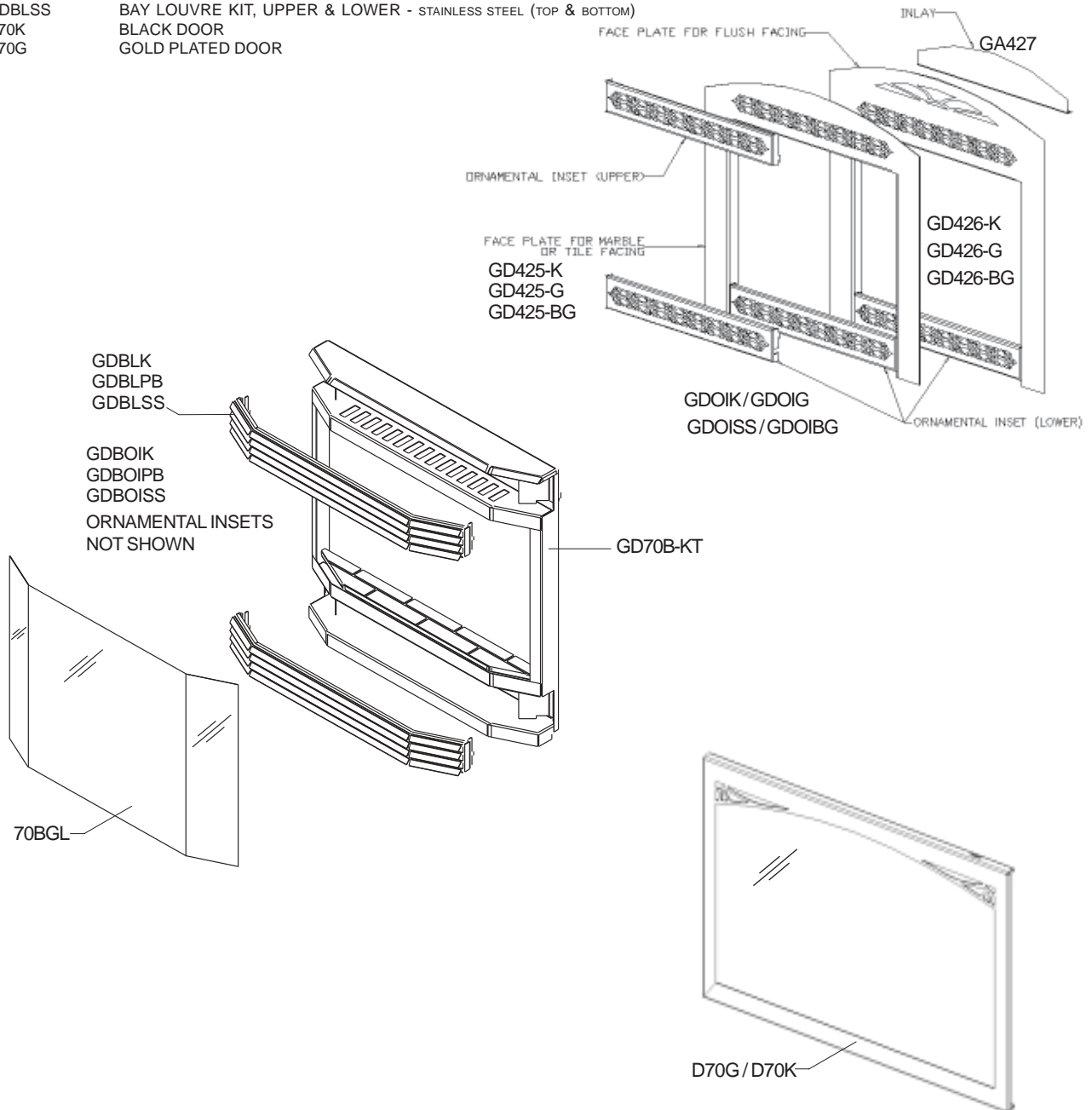

TROUBLE SHOOTING GUIDE

BEFORE ATTEMPTING TO TROUBLESHOOT, PURGE YOUR UNIT AND INITIALLY LIGHT THE PILOT AND THE MAIN BURNER WITH THE GLASS DOOR OPEN.

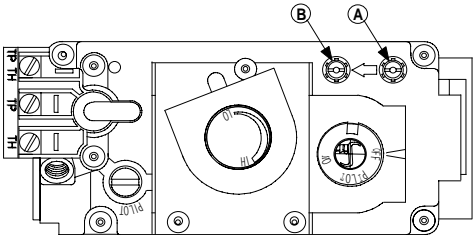
SYMPTOM	PROBLEM	TEST SOLUTION
Main burner flame is a blue, lazy, transparent flame.	Blockage in vent. Incorrect installation.	- remove blockage. In really cold conditions, ice buildup may occur on the terminal and should be removed as required. - refer to Figure 13 to ensure correct location of storm collars.
Flames are consistently too large or too small. Carboning occurs.	Unit is over-fired or under-fired.	- check pressure readings: Inlet pressure can be checked by turning screw (A) counter-clockwise 2 or 3 turns and then placing pressure gauge tubing over the test point. Gauge should read 7" (minimum 4.5") water column for natural gas or 13" (11" minimum) water column for propane. Check that main burner is operating on "HI". Outlet pressure can be checked the same as above using screw (B). Gauge should read 3.5" water column for natural gas or 10" water column for propane. Check that main burner is operating on "HI". AFTER TAKING PRESSURE READINGS, BE SURE TO TURN SCREWS CLOCKWISE FIRMLY TO RESEAL. DO NOT OVERTORQUE. Leak test with a soap and water solution.
		
Carbon is being deposited on glass, logs or combustion chamber surfaces.	Air shutter has become blocked Flame is impinging on the logs or combustion chamber.	- ensure air shutter opening is free of lint or other obstructions. - check that the logs are correctly positioned. - open air shutter to increase the primary air. - check the input rate: check the manifold pressure and orifice size as specified by the rating plate values. - check that the door gasketing is not broken or missing and that the seal is tight. - check that both 4" and 7" vent liners are free of holes and well sealed at all joints. - check that minimum rise per foot has been adhered to for any horizontal venting.
White / grey film forms.	Sulphur from fuel is being deposited on glass, logs or combustion chamber surfaces.	- clean the glass with a gas fireplace glass cleaner. DO NOT CLEAN GLASS WHEN HOT. If deposits are not cleaned off regularly, the glass may become permanently marked.
Exhaust fumes smelled in room, headaches.	Fireplace is spilling.	- check door seal and relief flap seal. - check for chimney blockage - check that that the paint curing process is complete
Pilot goes out when the gas knob is released.	System is not correctly purged.	- purge the gas line with the glass door open.
The gas valve has an interlock device which will not allow the pilot burner to be lit until the thermocouple has cooled. Allow approximately 60 seconds for the thermocouple to cool.	Out of propane gas.	- fill the tank.
	Pilot flame is not large enough	- turn up the pilot flame.
	Pilot flame is not engulfing the thermocouple.	- gently twist the pilot head to improve the flame pattern around the thermocouple.
	Thermocouple shorting / faulty.	- loosen and tighten thermocouple. - clean thermocouple and valve connection. - replace thermocouple. - replace valve.
	Faulty valve.	- replace.

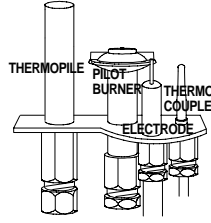
SYMPTOM	PROBLEM	TEST SOLUTION
Pilot burning; no gas to main burner; gas knob is on 'HI'; wall switch / thermostat is on.	Thermostat or switch is defective.	- connect a jumper wire across the wall switch terminals; if main burner lights, replace switch / thermostat.
	Wall switch wiring is defective.	- disconnect switch wires & connect a jumper wire across terminals 1 & 3; if the main burner lights, check the wires for defects and / or replace wires.
	Main burner orifice is plugged.	- remove stoppage in orifice.
	Faulty valve.	- replace.
Pilot goes out while standing; Main burner is in 'OFF' position.	Gas piping is undersized.	- turn on all gas appliances and see if pilot flame flutters, diminishes or extinguishes, especially when main burner ignites. Monitor appliance supply working pressure. - check if supply piping size is to code. Correct all undersized piping.
	Pilot will not light.	No spark at pilot burner
	Out of propane gas	- fill the tank.
	Spark gap is incorrect	- spark gap should be 0.150" to 0.175" (5/32" to 11/64" approx.) from the electrode tip and the pilot burner. To ensure proper electrode location, tighten securing nut (finger tight plus 1/4 turn).
	No gas at the pilot burner	- check that the manual valve is turned on. - check the pilot orifice for blockage. - replace the valve. - call the gas distributor.
Main burner goes out; pilot stays on.	Pilot flame is not large enough or not engulfing the thermopile	- turn up pilot flame. - replace pilot assembly.
	Thermopile shorting	- clean thermopile connection to the valve. Reconnect. - replace thermopile / valve.
	Remote wall switch wire is too long; too much resistance in the system.	- shorten wire to correct length or wire gauge.
	Faulty thermostat or switch.	- replace.
Main burner goes out; pilot goes out.	Refer to "MAIN BURNER GOES OUT; PILOT STAYS ON"	
	Vent is blocked	- check for vent blockage.
	Vent is re-circulating	- check joint seals and installation.
	4" flexible vent has become disconnected from fireplace.	- re-attach to fireplace.
Remote wall switch is in "OFF" position; main burner comes on when gas knob is turned to "ON" position.	Wall switch is mounted upside down	- reverse.
	Remote wall switch is grounding.	- replace.
	Remote wall switch wire is grounding.	- check for ground (short); repair ground or replace wire.
	Faulty valve.	- replace.

