

SUDS SENTRY

Innovation in water mitigation since 1987



PRODUCT DETAILS

Prevent possible water damage to finished floors and eliminate drain flashing installation when installing a Suds Sentry pan for washing machines. Our half inch flange allows most floor surfaces to be brought right up to the edge of the pan creating a clean finished look. The choice of color provides easy color match to many flooring styles.

MATERIAL SPECIFICATIONS

- Color choice of White or Latte
- High Impact Polystyrene
- Half inch perimeter flange
- Eight 3/16" diameter fastener positions located six inches from each corner
- Recessed strainer ledge for maximum drainage
- Utilizes a PVC 3" Drain

PRICING INFORMATION

- Standard list pricing varies based upon color selection and part number
- Standard list pricing does not change regardless of the number of knockouts (up to 2)
- Contact a distributor for pricing details!

DISTRIBUTION S/H INFORMATION

- Packaged in 25 units per carton. Smaller quantities maybe ordered.
- NMFTA National Motor Freight Classification is:
Plastic Products
NOI Item 156600
Sub 6 Class 100

SUDS SENTRY WASHING MACHINE PANS

Part No.	Knockout	Height	Drain Screen Recess	Number of Strainer Knockouts	Inner Dimension (in. x in.)	Outer Dimension (in. x in.)	Overall Flange (in. x in.)	Max. Rate of Removal (GPM)	Color
2731-W*	3-3/4"	1"	4-3/8"	1	29 x 25	31-3/8 x 27-7/16	32-1/8 x 27-7/16	64.70	White
2731-L*	3-3/4"	1"	4-3/8"	1	29 x 25	31-3/8 x 27-7/16	32-1/8 x 27-7/16	64.70	Latte
3333-1KO-W*	3-3/4"	1"	4 5/16"	1	30-13/16 x 30-13/16	32-13/16 x 32-13/16	33-13/16 x 33-13/16	64.70	White
3333-1KO-L*	3-3/4"	1"	4 5/16"	1	30-13/16 x 30-13/16	32-13/16 x 32-13/16	33-13/16 x 33-13/16	64.70	Latte
3333-2KO-W*	3-3/4"	1"	4 5/16"	2	30-13/16 x 30-13/16	32-13/16 x 32-13/16	33-13/16 x 33-13/16	64.70	White
3333-2KO-L*	3-3/4"	1"	4 5/16"	2	30-13/16 x 30-13/16	32-13/16 x 32-13/16	33-13/16 x 33-13/16	64.70	Latte
3335-2KO-W*	3-3/4"	2"	4-5/16"	2	33 X 35	35-1/2 x 37-1/2	36 x 38	91.49	White

Note: Stacking machines most often use number 2731 and front loaders generally use number 3335.

* This is a SPDP & Solutions part number. Each distributor's part number may vary.

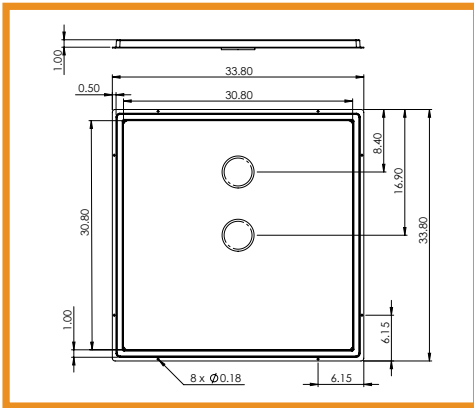

3333-2KO Pan Dimensions

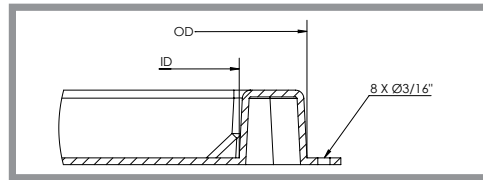

Figure A

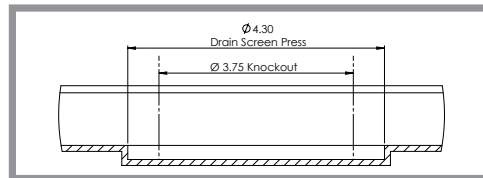

Figure B

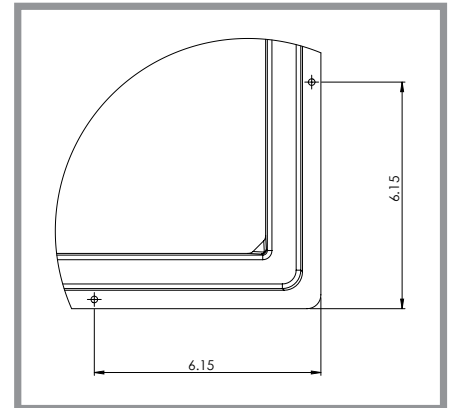
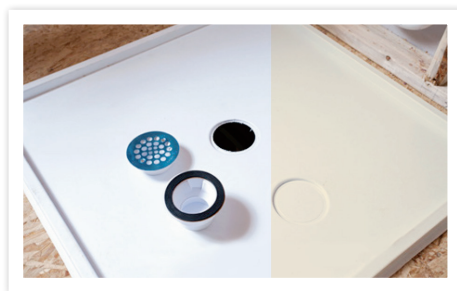

Figure C



AVAILABLE COLORS

White (W) & Latte (L)

Please contact us for a color chip if necessary.