

# Replacement Parts for Waste Valves

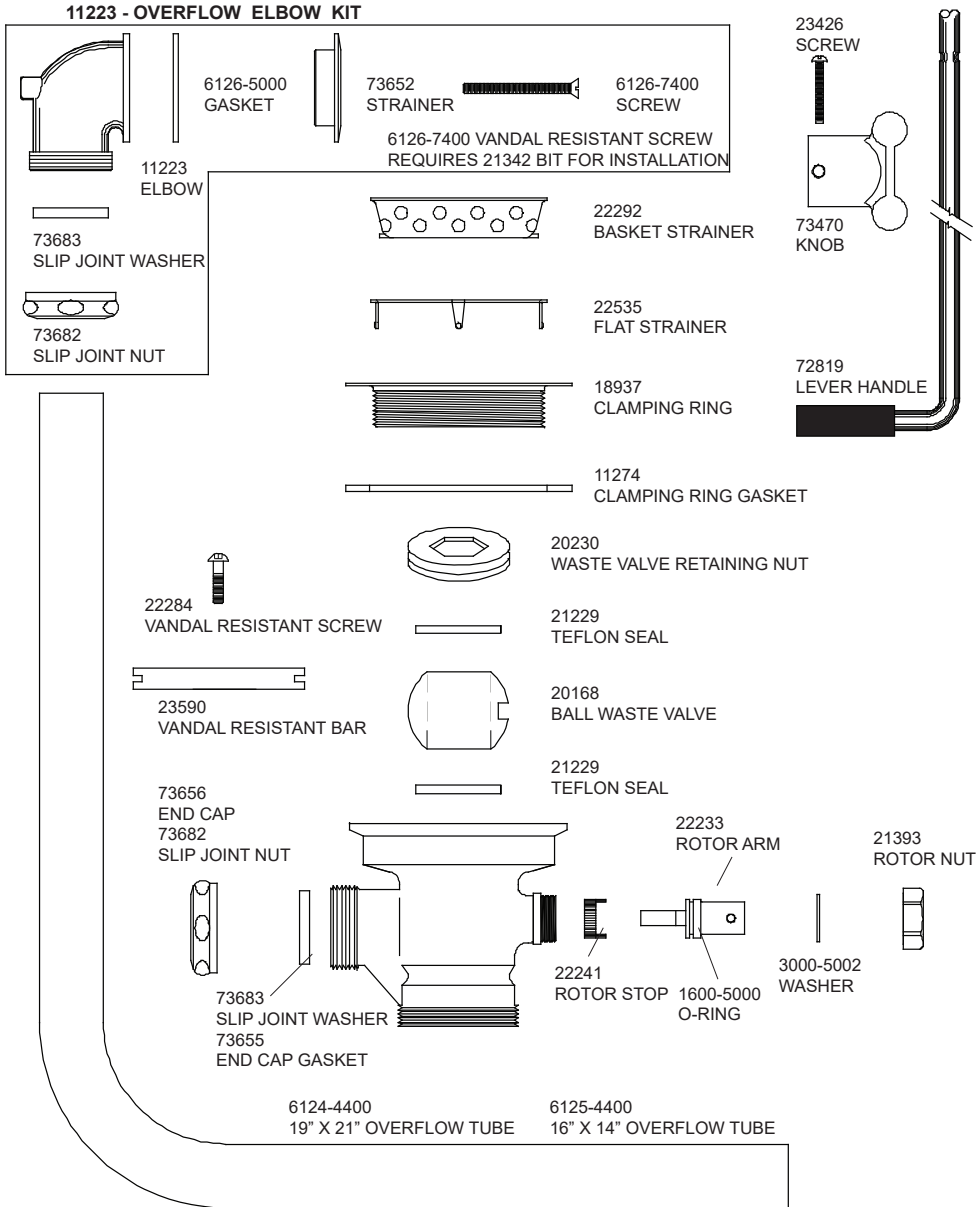

## Waste Valves Product Installation Guide

Since 1936, Fisher Manufacturing Company has manufactured heavy-duty, high quality plumbing products and hardware specialties for the food service industry. For three generations, the Fisher family has adhered to a strict dedication of and overall value. When you install Fisher products... you install the best. Our hardware is manufactured with the standardization of internal mechanisms. All chrome plating is triple plated copper, nickel and chrome for durability. Every piece of equipment we make is rigorously tested in both our modern in-house testing center and in actual field situations under extreme conditions. Every detail is thoroughly checked. Before we make our products available to you, they pass each and every test. You get proven performance. Guaranteed.

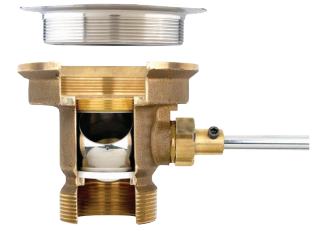

### Limited One Year Warranty

Fisher Manufacturing Company warrants its products and parts thereof (except as noted below) against defects in materials or workmanship for a period of one year after the date of original purchase. During this period Fisher Manufacturing Company will replace a defective product or part without charge to you, provided that the entire product is delivered to Fisher Manufacturing Company. All transportation and insurance charges for shipping the product to and from Fisher Manufacturing Company must be borne by you. Charges for transportation and insurance may, at the option of Fisher Manufacturing Company, be refunded depending upon our investigation of the warranty claim. This warranty does not cover external finish (except at date of original purchase) or labor costs not specifically authorized by Fisher Manufacturing Company.

A full and complete copy of our One Year limited warranty is available upon request.

**⚠ Warning:** This product can expose you to chemicals including Lead, Nickel (Metallic), Di(2-ethylhexyl) phthalate (DEHP) which are known to the State of California to cause cancer, and Lead, Di(2-ethylhexyl) phthalate (DEHP) which are known to the State of California to cause birth defects or reproductive harm. For more information go to:

[www.P65Warnings.ca.gov](http://www.P65Warnings.ca.gov).

- #22209- DRINKING FLAT STRAINER BRASS
- #22306- DRINKING W/FLAT STRAINER & 19" X 21" OVERFLOW BRASS
- #22314- DRINKING W/LOCKING BASKET STRAINER & 19" X 21" OVERFLOW BRASS
- #22322- DRINKING W/FLAT STRAINER & 14" X 16" OVERFLOW BRASS
- #22330- DRINKING W/LOCKING BASKET STRAINER & 14" X 16" OVERFLOW BRASS
- #22349- DRINKING W/ LOCKING BASKET STRAINER BRASS
- #22365- DRINKING FLAT STRAINER VR KNOB BRASS
- #22373- DRINKING W/FLAT STRAINER VR KNOB & 19" X 21" OVERFLOW BRASS
- #22381- DRINKING W/FLAT STRAINER VR KNOB & 14" X 16" OVERFLOW BRASS
- #22411- DRINKING W/LOCKING BASKET STRAINER OVERFLOW BRASS
- #22438- DRINKING FLAT STRAINER OVERFLOW BRASS
- #22446- DRINKING FLAT STRAINER VR KNOB OVERFLOW BRASS

KEEP THIS MANUAL FOR FUTURE REFERENCE



ANSI/A112.18.1M, ANSI/NSF 61.9

FISHER MANUFACTURING COMPANY - TOLL FREE: 800-421-6162 FAX: 800-832-8238

**FISHER**  
MANUFACTURING COMPANY  
PO BOX 60, TULARE, CA 93275  
(800)421-6162, FAX: (800)832-8238  
[www.fisher-mfg.com](http://www.fisher-mfg.com)

# Installation Instructions for Waste Valves

**BE SURE TO CHECK WITH YOUR LOCAL DEPARTMENT HAVING JURISDICTION REGARDING BACKFLOW PREVENTION**

## Installation Notes:

- Be sure to shut off water supply before beginning.
- Use pipe thread sealant such as PST on all threaded joints.
- Check the packaging for missing items BEFORE beginning installation. If items are missing, contact your supplier.

## Tools Required for Installation

- 1/8" Allen Wrench
- #3 Allen Wrench
- Channel Lock Pliers
- Spanner Wrench - Part #22780
- Vandal Resistant Models: Bit 21334 (Supplied)

## Installation of Valve Body Assembly to Existing Sink

1. Place gasket (C) on top of valve body (D).
2. Keeping gasket in place, butt the valve body against the bottom of the sink and hand tighten the clamping ring (B) into the valve body from inside of the sink. Note: Following normal plumbing practices, a small bead of silicone is recommended between the clamping ring and sink compartment.
3. Using a spanner wrench, completely tighten the clamping ring. Note: the hole in the rotor arm must be pointing towards the front of the sink as shown in Figure 1.
4. Insert handle (F) into hole and attach with screw (E)

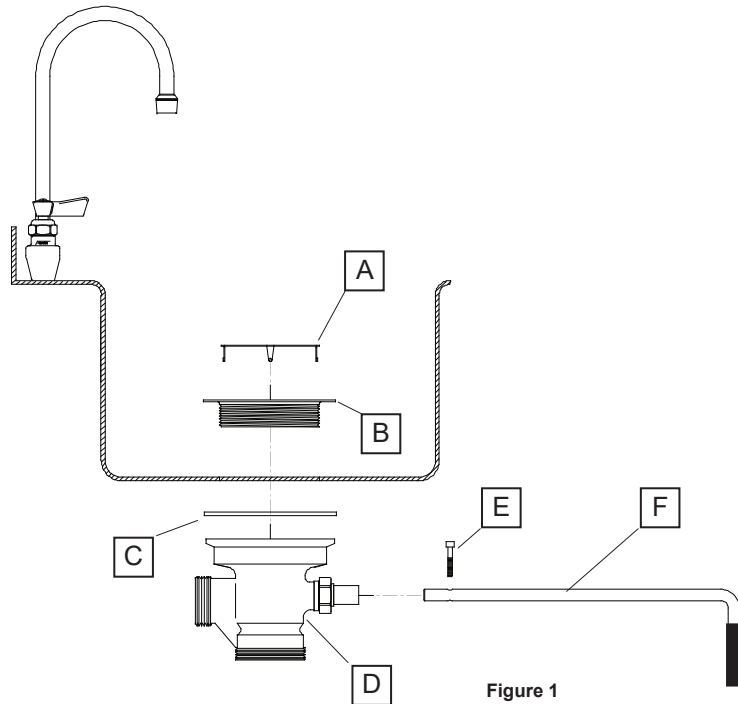

Figure 1

# Installation Instructions Continued

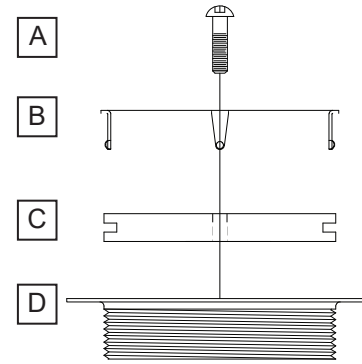

Figure 2

## Installation of Vandal Resistant Strainers

1. Slide vandal resistant bar (C) into slots in bottom of clamping ring (D) and rotate one quarter turn.
2. Snap flat strainer (B) into clamping ring.
3. Insert screw into center hole of flat strainer (B) until it reaches the hole in the middle of the vandal resistant bar (C) and tighten using a 1/8" Allen Wrench.

## Troubleshooting Tips

- **Teflon Seals-** Remove strainer. Unscrew the retaining nut, which contains one of the seals with a 1" Allen wrench. Pull the ball valve out from the top. The lower seal is now visible and can be removed. When replacing these seals make sure they are snapped firmly into place before reassembling your valve. See Figures 4 and 5.
- **O-ring-** In order to check this part for wear, it is necessary to (1) remove the handle, rotor nut and rotor. The O-ring is the small black rubber ring located on the rotor arm itself. Important: If while pulling the rotor arm out, the rotor stop is accidentally removed, it must be put back with the tabs in their original position in order to stop the handle in the proper position. See Figure 3

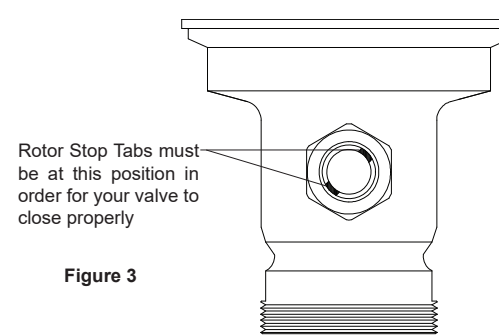

Figure 3

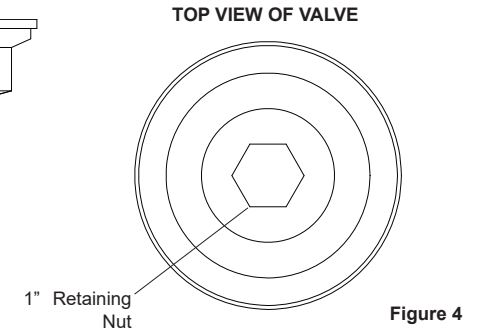

Figure 4

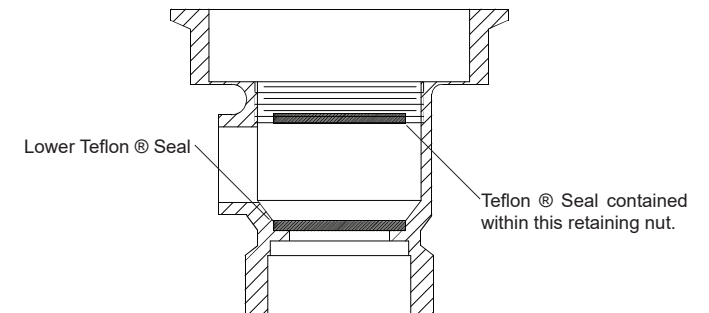

Figure 5