

# AV-150 AIR VENT

## AND VACUUM RELIEF VALVE

### USES:

Waterman Model AV-150 Air Vents are designed for evacuation of air when filling a pipe line and provide positive vacuum relief when pipe is draining. Use on gravity or higher pressure systems.

### FEATURES:

The Model AV-150 uses a semi-hard, precision ground, inert solid plastic float ball. The float seats against a precision "o-ring" providing a tight seal at very low pressures where other vents often leak. They have excellent seating characteristics and operate trouble-free at pressures up to 150 psi on the 1½" and 2" units and 100 psi on the 3" and 4" units.

The aerodynamic "air-flow" design of a high strength alloy aluminum body and full baffle assures maximum vent capacity without premature closing. Material selection prevents "sticking" in the closed position.

Units are furnished with standard female pipe threads which should be protected with "Never-Seize" or equivalent when installed.

|  |                          |
|--|--------------------------|
| <b>VENT CAPACITY = INLET SIZE</b>                  |                          |
| <b>VACUUM RELIEF CAPACITY = CLEAR OPENING SIZE</b> |                          |
| 1½" INLET  | = 1⅛" dia. clear opening |
| 2" INLET   | = 1¾" dia. clear opening |
| 3" INLET   | = 2⅜" dia. clear opening |
| 4" INLET   | = 3½" dia. clear opening |



MODEL AV-150

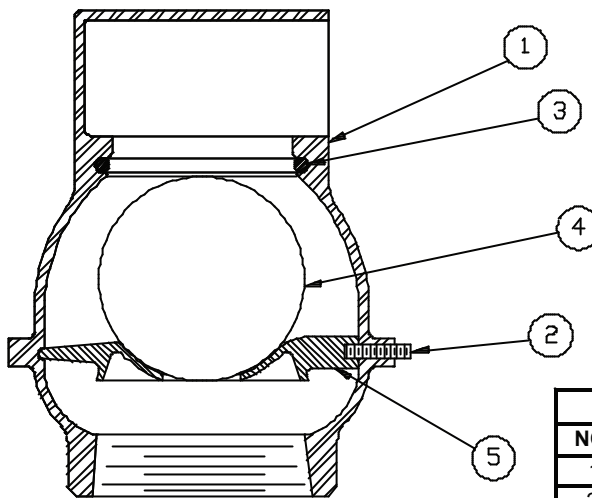

| PARTS LIST |            |
|------------|------------|
| NO.        | NAME       |
| 1          | Body       |
| 2          | Set Screw  |
| 3          | O-Ring     |
| 4          | Float Ball |
| 5          | Baffle     |

### DISCHARGE CURVES

