

Installation & Maintenance Manual



L42DF Indoor

L-Series
Residential
Fireplace

DANGER

Read and understand this manual. Improper installation, adjustment, alteration, service or maintenance can cause serious injury, property damage or even death. For assistance or additional information consult a qualified installer, service agency or the gas supplier.

CAUTION

Glass doors on gas fireplaces are **extremely hot** while the fireplace is on and remain hot even after the fireplace has been turned off. Safety screens are available and can reduce the risks of severe burns. Please keep children away from the fireplace at all times.

WARNING

Do not store or use gasoline or any other flammable vapors and liquids in the vicinity of this or any other gas burning appliance. A fire or explosion may occur causing serious injury, property damage or even death.





NOTICE

Installer: Leave this manual with the appliance. Do not remove.
Consumer: Retain this manual for maintenance and future reference. Do not Discard.



DANGER

IF YOU SMELL GAS

-  Do not try to light any appliance.
-  Do not touch any electrical switch; do not use any phone in your building.
-  Immediately call your gas supplier from a neighbor's phone. Follow the gas supplier's instructions.
-  If you cannot reach your gas supplier, call the fire department.



NOTICE

You must read and understand this manual prior to installation, operation or troubleshooting this appliance. Please retain this owner's manual for future reference and maintenance.

Table of Contents

Instruction Manual Contents		Maintenance	35
Safety Alerts.....	3	Lighting Instructions See pages 25 to 26.....	35
Introduction.....	3	General.....	35
Section A: Before You Start.....	4	Cleaning.....	35
Installation Checklist.....	4	Hi-Lo Burner Adjustment: (SIT Nova 820).....	35
Rating Plate Sample.....	5	Hi-Lo Burner Adjustment: (SIT Proflame 2).....	35
Section 1: Installation Overview and Product Dimensions.....	6	Pilot Burner Adjustment.....	35
Section 2: Framing.....	7	Troubleshooting.....	36
Clearances.....	8	SIT Nova 820:.....	36
Section 3: Venting.....	10	SIT Proflame 2:.....	36
Section 3-1: Converting To Rear Vent.....	10	Replacement Parts:.....	37
Section 3-2: Installing a Roof Mounted Direct Vent Termination (PVTk-1).....	11	Appendix A: Venting Terminations.....	38
Section 3-2-1: Venting Layout.....	11	Appendix B: Warranty.....	39
Section 3-3-1: Venting Layout: Wall mounted termination.....	14	Appendix C: State of Massachusetts.....	40
Section 3-3-2: Venting Components.....	18		
Section 3-3-3: Heat Shields.....	19		
Section 4: Wiring.....	20		
CPI [Continuous Pilot Ignition] / IPI [Intermittent Pilot Ignition]			
Jumper Cable Installation.....	22		
Section 5: Installing the Gas Line.....	23		
Section 5-1: FUEL CONVERSION.....	23		
Section 5-2: GAS PRESSURE.....	23		
Section 5-3: GAS CONNECTION.....	23		
Section 6: Finishing.....	24		
Section 7: Screen Installation and Removal.....	25		
Section 8: Installing & Removing the Door.....	26		
Section 9: Start-up Sequence.....	28		
SIT Proflame 2 Electronic Ignition.....	29		
Optional Remote Operation.....	30		

Safety Alert Key

Safety Alerts



DANGER

Indicates a hazardous situation which, if not avoided, WILL result in death or serious injury or property damage.



WARNING

Indicates a hazardous situation which, if not avoided, COULD result in death or serious injury or property damage.



CAUTION

Indicates a hazardous situation which, if not avoided, WILL result in minor or moderate injury.

NOTICE

Addresses practices that are important, but not related to personal injury

Introduction

Introduction

Congratulations on your purchase of a Montigo Fireplace.

With over 30 years of experience, Montigo is committed to providing you with a gas fireplace that is not only a beautiful addition to your space, but that is also designed and manufactured to the highest safety, reliability and engineering standards.

We strongly encourage you to read and carefully follow the instructions laid out in this Installation, Operation and Maintenance Manual and retain it for your future reference. Pay special attention to all cautions, warnings, and notices throughout this manual intended to ensure your safety.

This manual covers installation, operation and maintenance. Lighting, operation and care of this fireplace can be easily performed by the homeowner. All installation and service work should be performed by a qualified or licensed installer, plumber or gas fitter as certified by the state, province, region or governing body where the fireplace is being installed.

This installation, operation and maintenance manual is applicable to the models described in the table. Refer to your rating plate to verify included options. Throughout this instruction guide, instructions are applicable to all models designated as L42DF* unless otherwise noted.

MODEL	Natural Gas	Liquid Propane	Gas Rating (BTU hr)	Traditional Burner / Logset	Contemporary Burner w/ River rock	Linear Burner w/ Glass media Accessories	Standing Pilot Ignition	SIT Electronic Ignition
L42DFN	X		32,000			X	X	
L42DFN-F	X		32,000			X		X
L42DFL		X	32,000			X	X	
L42DFL-F		X	32,000			X		X

Warranty Information: (See Appendix B)

The Montigo warranty will be voided by, and Montigo disclaims any responsibility for the following actions:

- ▶ Modification of the fireplace and/or components including Direct-Vent assembly or glass doors.
- ▶ Use of any component part not manufactured or approved by Montigo in combination with this Montigo fireplace system.
- ▶ Installation other than as instructed in this manual.

Consult your local Gas Inspection Branch on installation requirements for factory-built gas fireplaces. Installation & repairs should be done by a qualified contractor.



CAUTION

Young children should be carefully supervised when they are in the same room as the appliance. Toddlers, young children and others may be susceptible to accidental contact burns. A physical barrier is recommended if there are at risk individuals in the house. To restrict access to a fireplace or stove, install an adjustable safety gate to keep toddlers, young children and other at risk individuals out of the room and away from hot surfaces.



Installation

Section A: Before You Start

IMPORTANT MESSAGE: SAVE THESE INSTRUCTIONS

The L42DF* Direct Vent fireplace must be installed in accordance with these Instructions. Carefully read all the Instructions in this manual first. Consult the Local Gas Branch to determine the need for a permit prior to starting the installation. It is the responsibility of the installer to ensure this fireplace is installed in compliance with the manufacturers instructions and all applicable codes.

BEFORE YOU START:

NOTICE

Installation and repairs should be done by an authorized gas fireplace service technician. The appliance should be inspected before use and at least annually by a professional. More frequent cleaning may be required due to excessive lint from carpeting, bedding material, etc. It is imperative that control compartments, burners and circulating air passageways of the fireplace are kept clean.



CAUTION

Due to high operating temperatures, this appliance should be located out of traffic & away from furniture and draperies.
Children and adults should be alerted to the hazards of the high surface temperature, which could cause burns or clothing ignition.
Young children should be carefully supervised when they are in the same room as the appliance.
Clothing or other flammable materials should not be placed on or near the appliance.



DANGER

When this appliance is installed directly on any combustible material other than wood flooring, it must be installed on a metal or wood panel extending the full width and depth of the appliance or a fire will occur causing serious injury, property damage or even death.

Installation Checklist

- Determine the desired install location of your fireplace.
- See Section 1, Dimensions on Page 6, and refer to the Framing Section 2 for details.
- Select the location of your termination and resulting vent run.
- Your selected termination location must be the highest point in the Direct Vent installation.
- Should it be impossible to meet the venting requirements laid out in Section 3: Venting, please contact a local Montigo dealer regarding the use of a Montigo Power Vent.
- Lay out the Vent run; calculating the required elbows and straight runs of 5"/8" flex and/or rigid pipe.
- Layout Electrical Requirements Refer to Section 4: Wiring, for Details.
- Refer to Section 5: Installing the Gas Line, for details on the gas connection and access.
- Refer to local codes and guidelines for installation requirements.
- Installation and repairs should be done by a qualified contractor and must conform to:

- Installations in Canada must conform to the local codes or in the absence of local codes to the current version of Natural Gas and Propane Installation Code, CSA B149. Electrical Installations must conform to the local codes or, in the absence of local codes, to the current version of Canadian Electrical Code, CSA C22.1.1

- Installations in the USA must conform to the local codes or in the absence of local codes to the current version of National Fuel Gas Code, ANSI Z223.1/NFPA 54. Electrical Installations must conform to the local codes or, in the absence of local codes, to the current version of the National Electrical Code, ANSI/NFPA 70. See Appendix C for installation within the State of Massachusetts.

WARNING

A barrier designed to reduce the risk of burns from hot viewing glass is provided with this appliance and shall be installed for the protection of children and other at-risk individuals.

If the barrier becomes damaged, the barrier shall be replaced with the manufacturer's barrier for this appliance.

WARNING

Any safety screen, guard, or barrier removed for servicing an appliance must be replaced prior to operating the appliance.



Installation

Rating Plate Sample



Do Not Remove This Label
N'enlevez Pas Cette Étiquette

Type: Vented Gas Fireplace Heater **For Indoor Use Only**

Model No. Modèle: L42DF

Serial No.: 1-141215-000000

Manufacturer / Fabricant: Canadian Heating Products Inc., Langley BC, (www.montigo.com)
Montigo DelRay Corp., Ferndale, WA, (www.montigo.com)

Tested To / Examiné À: ANSI Z21.88 / CSA 2.33-2014

Electrical Rating / Estimation Électrique: With Elec. Ign or Fans, 115V / 1 Ph, 60 Hz / less than 12A

Altitude Rating / Estimation D'Altitude: N & H (0 - 4500 ft. / 0 - 1371 m.)

Fuel Type / Type De Carburant:

<input checked="" type="checkbox"/> N - Natural Gas / Gaz Naturel	Max. Input BTU/H	Min. Input BTU/H	Output / Rendement BTU/H	Orifice Size / Taille D'Orifice Front/Avant Rear/Derrière	Gas Manifold Pressure / Pression D'Admission Du Gaz	Min. Gas Supply Pressure/ Min. Pression D'Alimentation Du Gaz
<input type="checkbox"/> LP - Propane / Gaz Propane	32,000	25,000	N/A	2@49 DMS / N/A 2@56 DMS / N/A	3.5" W.C.	5.5" W.C.
	32,000	25,000	N/A		10" W.C.	11" W.C.

FOR USE WITH GLASS DOORS AND SCREENS CERTIFIED WITH THE APPLIANCE ONLY
Pour utilisation avec portes de verre and écrans de certifiés avec l'appareil seulement

***Refer to installation manual for more information.**
*Référez-vous au manuel d'installation pour plus d'information.

LEI 1223-V5.1 SIT IPT -with screen DEC06.2014

Figure A: Rating Plate for IPI electronic ignition

Type: Vented Gas Fireplace Heater **For Indoor Use Only**

Model No. Modèle: L42DF

Serial No.: 1-141215-000000

Manufacturer / Fabricant: Canadian Heating Products Inc., Langley BC, www.montigo.com
Montigo DelRay Corp., Ferndale, WA, www.montigo.com

Tested To / Examiné À: ANSI Z21.88 / CSA 2.33-2014

Electrical Rating / Estimation Électrique: With Elec. Ign or Fans, 115V / 1 Ph, 60 Hz / less than 12A

Altitude Rating / Estimation D'Altitude: N & H (0 - 4500 ft. / 0 - 1371 m.)

Fuel Type / Type De Carburant:

<input checked="" type="checkbox"/> N - Natural Gas / Gaz Naturel	Max. Input BTU/H	Min. Input BTU/H	Output / Rendement BTU/H	Orifice Size / Taille D'Orifice Rear/Derrière Front/Avant	Gas Manifold Pressure / Pression D'Admission Du Gaz	Min. Gas Supply Pressure/ Min. Pression D'Alimentation Du Gaz
<input type="checkbox"/> LP - Propane / Gaz Propane	32,000	25,000	N/A	3@52 DMS / N/A 3@62 DMS / N/A	3.5" W.C.	5.5" W.C.
	32,000	25,000	N/A		10" W.C.	11" W.C.

FOR USE WITH GLASS DOORS AND SCREENS CERTIFIED WITH THE APPLIANCE ONLY
Pour utilisation avec portes de verre and écrans de certifiés avec l'appareil seulement

***Refer to installation manual for more information.**
*Référez-vous au manuel d'installation pour plus d'information.

LEI 1205-V6.1 Stand Pilot- Screen DEC06.2014

Figure B: Rating Plate for standing pilot (SIT)



Installation

Section 1: Installation Overview and Product Dimensions

Please review the Installation Checklist on Page 4 for general information on preparing for a successful installation of your fireplace.

The L42DF* fireplace may be installed in any location that maintains proper clearances to air conditioning ducts, electrical wiring and

plumbing. Safety, as well as efficiency of operation, should be considered when selecting the fireplace location. Select a location that does not interfere with room traffic, has adequate ventilation and offers an accessible path for Direct Vent installation.

The fireplace dimensions are shown below:

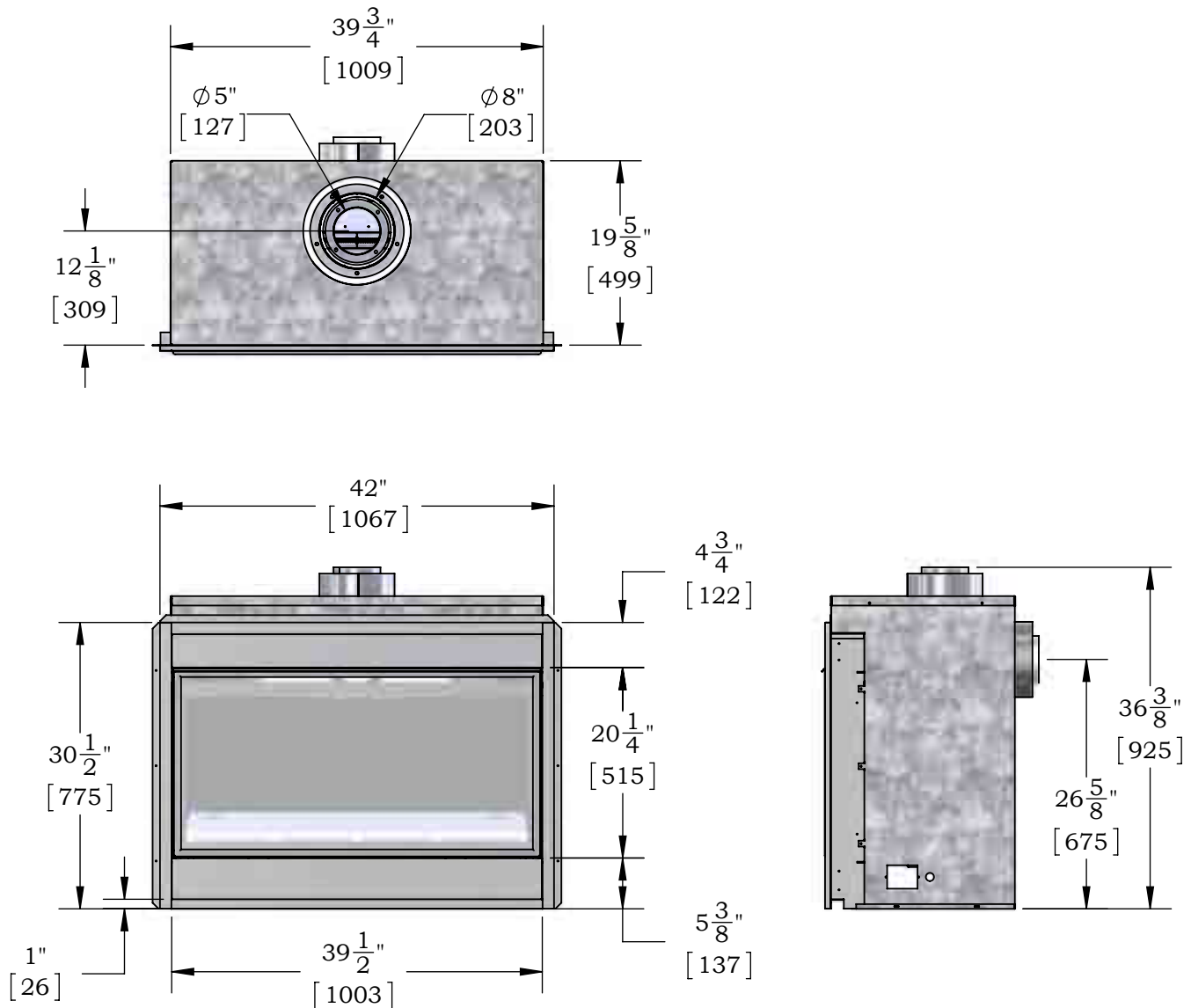

Figure 1: Unit Dimensions shown with nailing flange (Tolerance $\pm \frac{1}{8}$ ").

Installation



Section 2: Framing

Frame in the enclosure for the unit with framing materials. The framed opening for the assembled fireplace is 42" wide, x 37" high x 22⁵/₈" deep, see Figure 2.

NOTE: When constructing the framed opening, please ensure there is access to install the gas line when the unit is installed. See Figure 24.

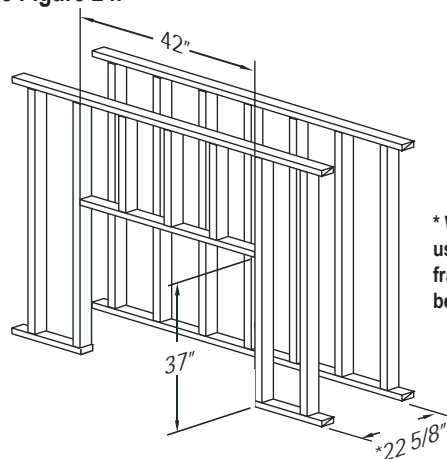

* When sheetrock is not used behind the fireplace, framing depth 22⁵/₈" may be reduced by 5/8".

Figure 2. Framing dimensions, Straight wall.

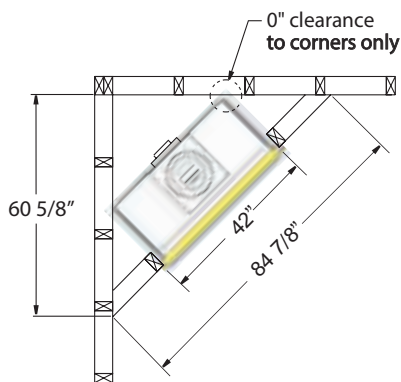

Figure 3. Minimum Corner framing dimensions

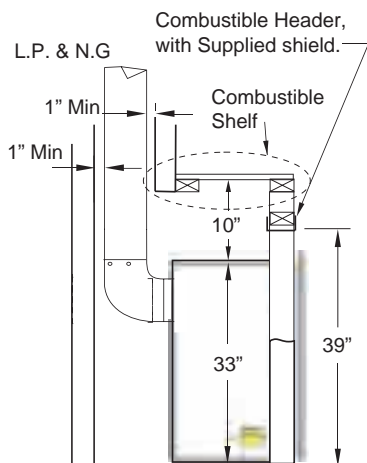

Figure 4. Combustible Framing for Rear Vent, with shelf above fireplace.

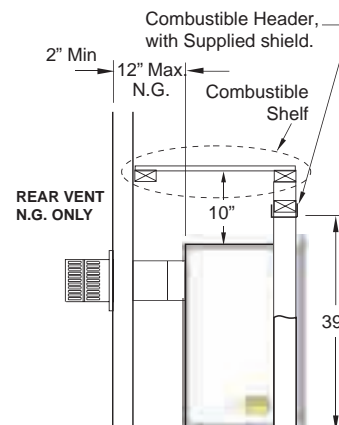
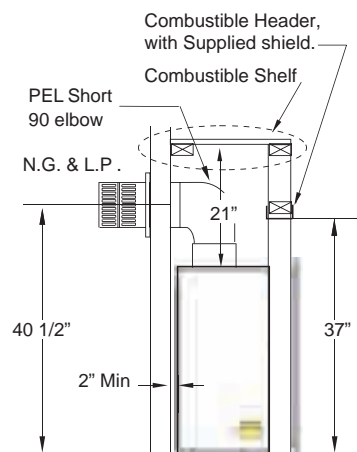

Figure 4a. Combustible Framing for Rear Vent with shelf above the fireplace. Note: Straight through the wall rear vent available for Natural Gas only.



Note: Images are shown without screens for clarity purposes. However, your fireplace should not be operated without proper installation of screens.



Installation

Fireplace without standard screen (pre-January 2015 manufacturing).

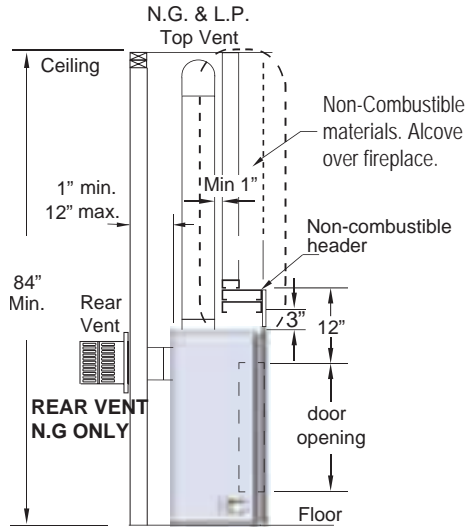

Fireplace with standard screen (post January 2015 manufacturing).

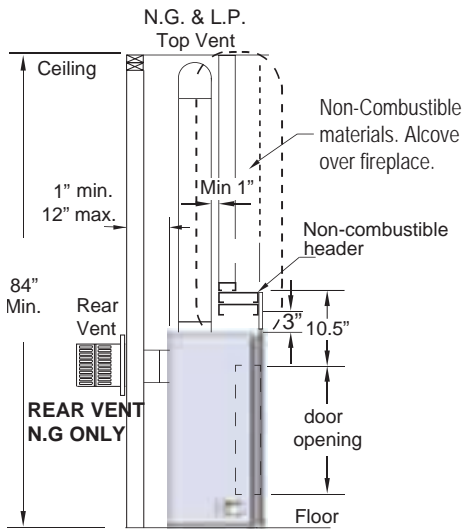

Figure 5. Combustible Framing for shelf over the fireplace, Top vent.

Clearances

1" clearance is maintained on sides and bottom of vent runs and 2" above horizontal vent runs to any combustible material.

MODEL	Top - Rear vent †	Top - Top vent †	Rear	Sides	Floor	Mantel
L42DF*	10"	21"	2"	1"	0"	See Section 6 Finishing around the fireplace

† NOTE: Clearance from top of fireplace to a ceiling within the fireplace enclosure.

When installing a shelf over the top of the fireplaces, the following guidelines must be adhered to:

For Rear Vent applications, the minimum clearance is 2" from the rear of the fireplace to a wall, or any combustible materials, and 10" clearance from the top of the fireplace to the underside of any combustible shelf materials.

For Top Vent applications, the minimum clearance is 2" from the rear of the fireplace to a wall, or any combustible materials, and 21" to the underside of any combustible shelf materials.

Installing The Standoffs

To avoid elevated mantel temperatures, all L42DF* gas fireplaces are required to have the supplied standoffs installed. The fireplace is supplied with two standoffs. Bend and install these standoffs on top of the fireplace ensuring that the height of the standoff maintains a 4" clearance.

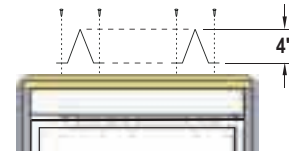

Figure 7. Installing the standoffs.

Installing the Nailing Flange Extension

Once the fireplace is placed into the rough framed opening, the supplied Nailing Flange Extension (Part No. L42087) must be fasten securely into place, with nails or wood screws, as shown in Figure 8.

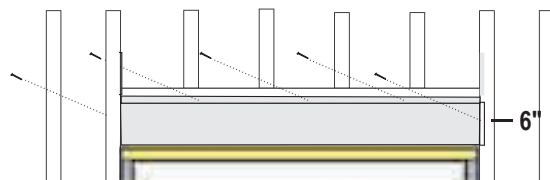

Figure 8. Installing the Nailing Flange Extension.

Note: The nailing flange extension can be substituted with a piece of NON-Combustible material of the same size and thermal characteristics, ie: cement board or equivalent. This is recommended in applications where the facing materials will not adhere to the metal nailing flange.

Installation



Framing the Heat Shield

Included with the L42DF* Gas fireplace, is a framing heat shield Kit. This Kit is fabricated from galvanized steel and arrives with three (3) pieces, as shown below. The shields protect all adjacent combustible materials, mantels and mouldings from excessive heat radiated by the fireplace.

NOTE: The shields must be installed as shown in Figures 9 - 9b.

Step 1. Fasten the two Side shield's (L42FS01x2) first, and ensure they are fastened in place as shown. These are installed with the Wide flanges facing the center of the fireplace opening, and the shallow flange toward inside of room. These are also fastened with nails or screws, flush with framing as shown in Figure 9 and Inset.

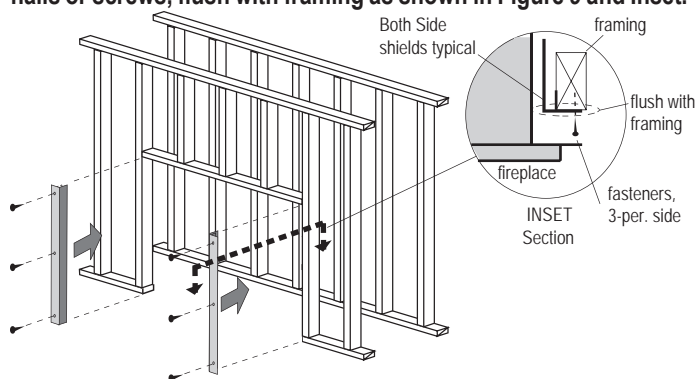

Figure 9. Combustible Framing Side Heat Shield L42FS01x2, (two 2-pcs).

Step 2. Next, fasten the Top shield (L42FS02x1), with the Wide flange face up, and the shallow flange toward inside of room, Figure 9a.

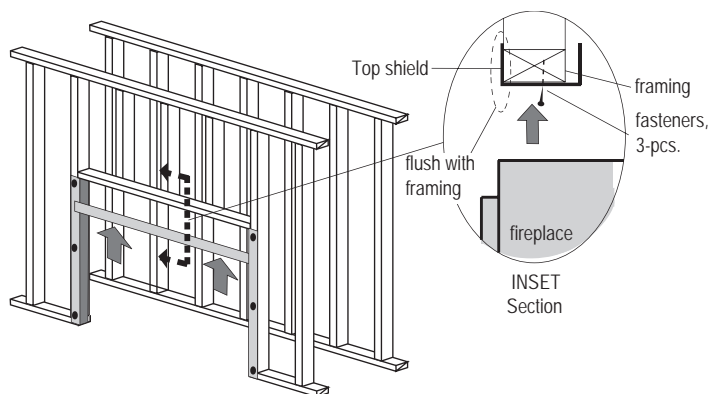

Figure 9a. Combustible Framing Top Heat Shield L42FS02x1, (one 1-pc).

Step 3. Nail or screw the top shield in place flush with framing, as shown in figure 9b.

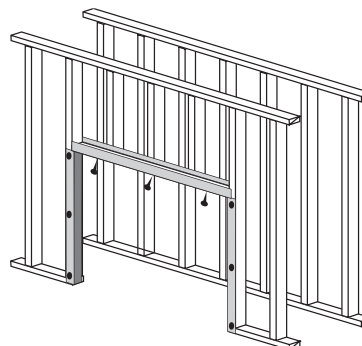

Figure 9b. Combustible Framing Heat Shield, completed.



Installation

Section 3: Venting

Montigo supplies a variety of direct venting and termination options. The direct vent termination location **MUST** be selected such that it is the highest point in the venting assembly. It should also be selected such that it provides the shortest vent run possible. Should it be impossible to ensure that the termination is the highest point or to meet the venting guidelines laid out below please contact your Montigo dealer to discuss power venting options.

NOTES FOR PLANNING VENTING:

- Venting originates from the unit through the top or through the rear
- Venting can terminate through the roof or through an exterior wall.
- Refer to Appendix A - Termination Locations to ensure the planned termination location is acceptable.
- Once the termination location has been established, refer to the appropriate section below for installation details
- All fireplaces shipped from the factory are Top vent.
- Silicone application is **NOT** required when joining Montigo vent pipes and components.

Section 3-1: Converting To Rear Vent

Use the following instructions to convert an L42DF* for Rear Vent use:

1. Remove the Rear flue cover and gasket (5" and 8") on the flue outlet, as shown in Figure 10.
2. Next, Remove the Top flue collar's (5" and 8") on the flue

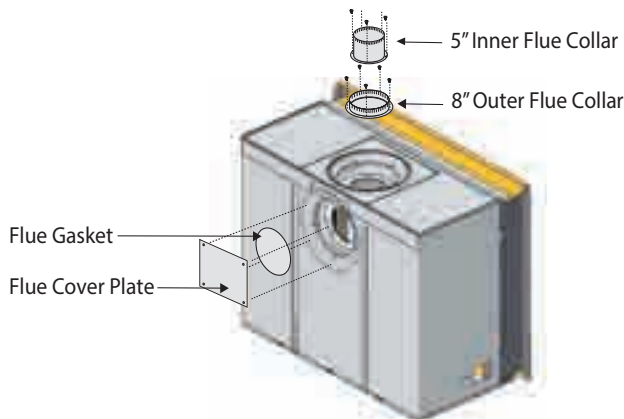

Figure 10. Flue cover and collar removal, Top Vented fireplace.

outlet, as shown in Figure 10.

3. Install the (removed) Rear flue cover and gasket material, to the Top vent outlet. Fasten the cover with included hardware, as illustrated Figure 10a.
4. Install the (5" and 8") collars to the rear vent outlet using the included hardware, as illustrated Figure 10a.

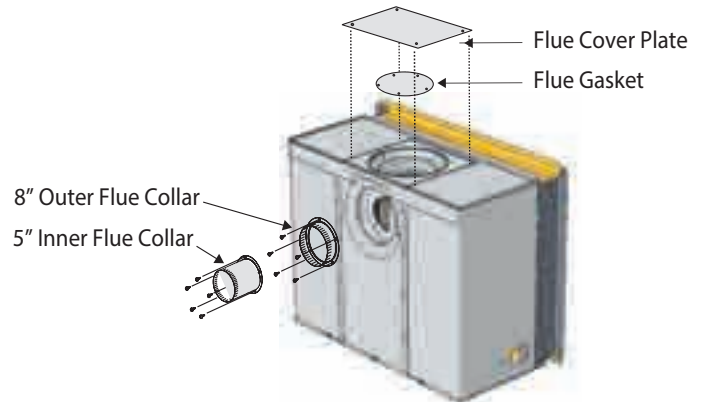

Figure 10a. Flue cover and collar installation, Rear Vented fireplace.

Note: Images are shown without screens for clarity purposes. However, your fireplace should not be operated without proper installation of screens.

Installation



Section 3-2: Installing a Roof Mounted Direct Vent Termination (PVTk-1)

This section applies to installations where the direct vent termination will be roof mounted.

Section 3-2-1: Venting Layout

Selection of components and details of venting lay out should adhere to the following guidelines:

- The maximum termination point is 32' above the fireplace (NOTE: if the maximum termination height is used, the flame pattern may be affected).
- The Vertical termination must be a minimum 2' higher than where the termination exits the roofing materials, (asphalt shingles, cedar shakes, etc). This distance should be measured from the high side of the roof slope where the flue flashing intersects the roofing materials. (see Figures 11 to 11c).
- Termination location must be a minimum 6' from a mechanical air inlet.
- For a more detailed diagram of allowed termination locations, see Appendix A .
- A maximum of two offsets (each offset is made up of 2-90° bends) may be made for vertical vent runs.
- Firestops must be installed as required by National & local codes.
- Ensure all horizontal runs are supported with a minimum of 3 supports per 10' of venting.
- Install all roof flashing and storm collars as shown.

Roof mounted Terminations

The following details are some possible configurations for Roof mounted terminations.

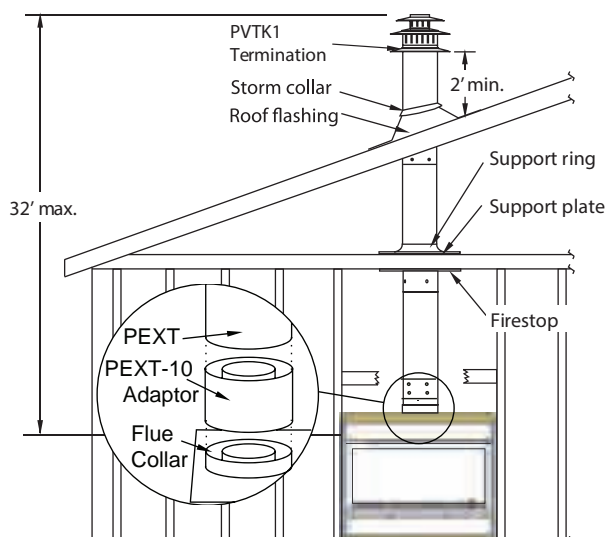

Figure 11. Top vent, Roof mounted termination with no offset in vent run.

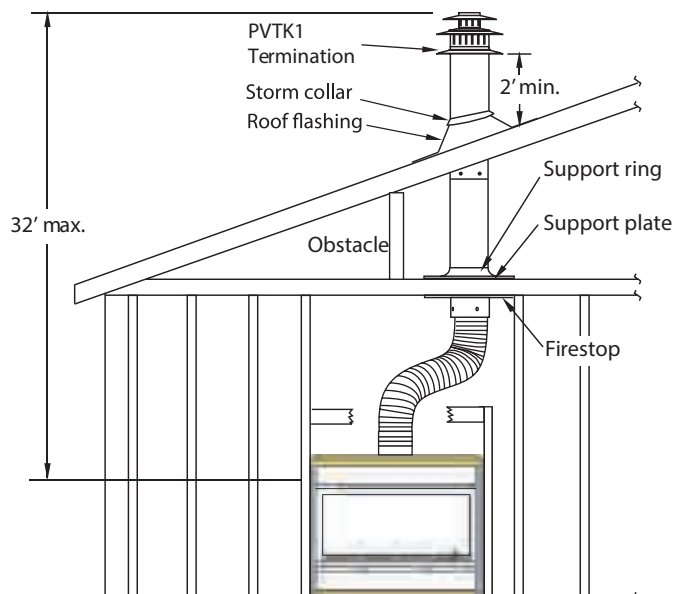

Figure 11a. Top vent, Roof mounted with 1 offset (1 offset= two 90° bends).

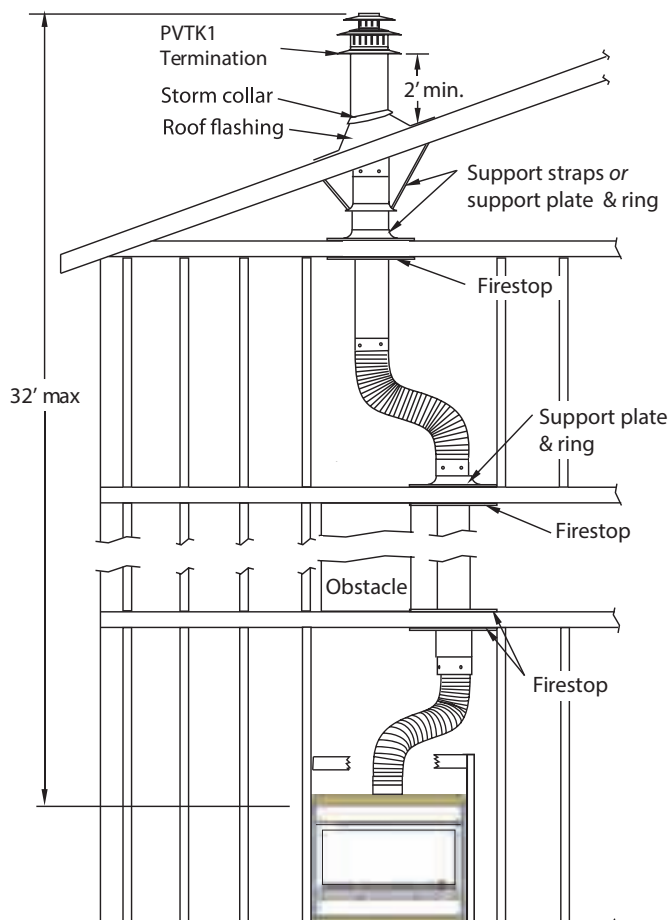

Figure 11b. Top vent, Roof mounted with 2 offsets (1 offset= two 90° bends).



Installation

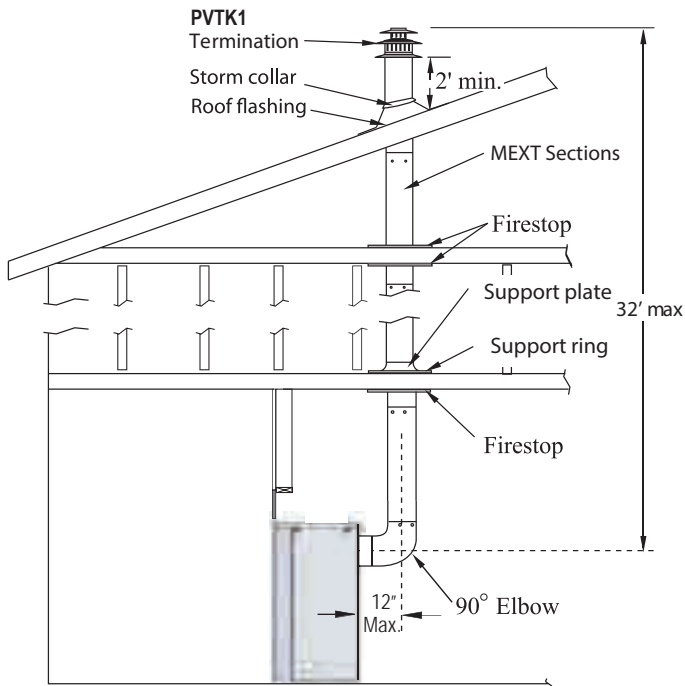

Figure 11c. Rear vent, Roof mounted venting (1 = 90° bend).

Note: Images are shown without screens for clarity purposes. However, your fireplace should not be operated without proper installation of screens.

Installation



Section 3-3: Installing a Wall Mounted Direct Vent Termination

This section applies to installations where the direct vent termination will be wall mounted.

Installation of Termination with built in frame

A Termination with a Built-In Frame is installed during framing of a structure.

1. Frame the termination opening to 11" x 11".
2. Install exterior sheathing to the structure framing.
3. Fasten the termination to the sheathing using a minimum of 4 screws.

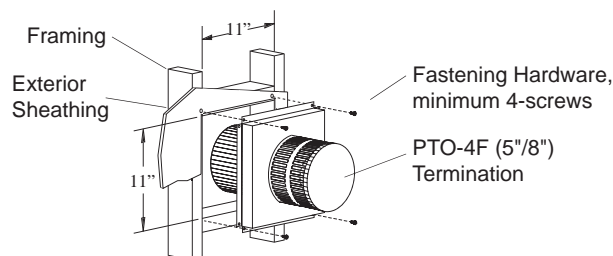

Figure 12. Installing a PTO-F termination.

Installation of termination frame at time of framing

Terminations with a MSR frame allow the installation of the frame prior to installation of the termination.

1. Frame the termination opening to 12" x 12".
2. Secure the MSR Frame to the exterior sheathing of the structure.
3. Fasten the termination to the MSR Frame using a minimum of 4 screws.

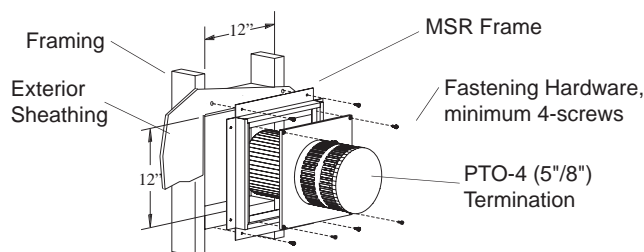

Figure 12a. Installing a PTO termination with the MSR frame.

Installation of termination frame at time of framing in Masonry

Terminations with a BSR frame allow the installation of the frame in masonry prior to the installation of the termination

1. Frame the BSR opening to 12" x 12".
2. Secure the BSR Frame to the exterior sheathing of the structure.
3. Fasten the termination to the BSR Frame using a minimum of 4 screws.

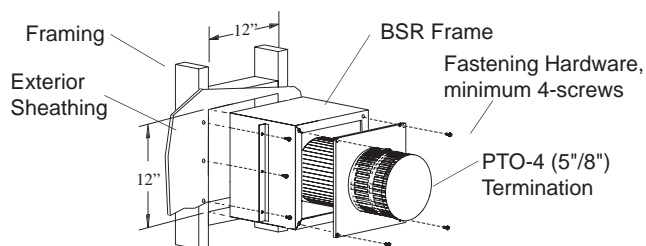

Figure 12b. Installing a PTO termination with the BSR frame.

Installation of termination from inside structure

A Termination with a MOSR Frame is installed from the inside of the structure. These are commonly used in high-rise construction.

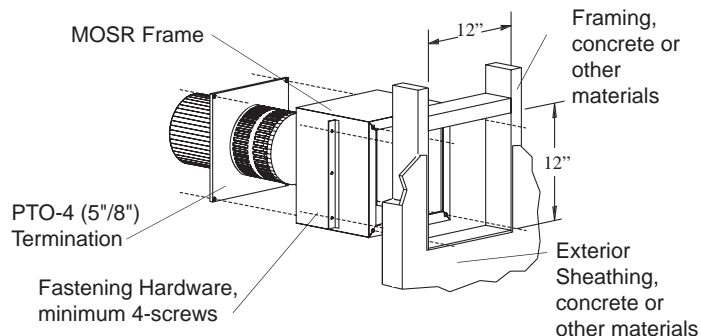

Figure 12c. Installing a PTO termination with MOSR frame.

1. Frame the MOSR opening to 12" x 12".
2. Fasten the MOSR frame to the interior side of the studs, concrete, or finished wall construction using a minimum of 4 screws.
3. Insert the termination into the MOSR frame as shown here, (from the inside) and attach to the MOSR by installing a min. quantity of 4 bolts into the threaded nuts on the MOSR Frame.

Installation of a termination shield for Vinyl Siding

The VSS Termination shield is installed when the exterior of a structure is clad with Vinyl siding. It is placed directly above, and on-centre with the termination.

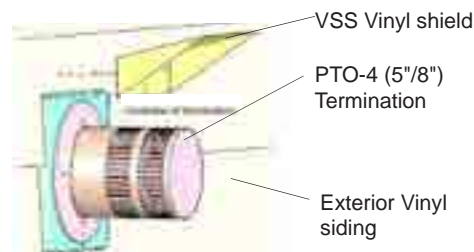

Figure 12d. Installing the VSS Vinyl Shield.

Installing Heat Guards over Terminations is recommended in installations where the termination is located within 7' feet above grade, or above a pedestrian walkway, and may be Required by code in Public areas.

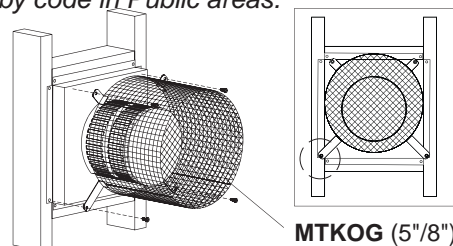

Figure 13. Installing a PTO termination heat guard.

1. Ensure that the two long mounting brackets are facing the bottom of the termination. (See inset). This will provide more heat protection at the top of the termination, where temperatures are highest.
2. Attach to the faceplate of the termination using four sheet metal screws.



Installation

Section 3-3-1: Venting Layout: Wall mounted termination.

Selection of components and details of venting layout should adhere to the following guidelines:

- Vent terminations must not be recessed in walls or siding.
- For Heat Shield requirements see Section 3-3-3.
- Once the proposed venting layout has been determined refer to Figure 14 or 16 to ensure the layout is acceptable.

Notes Wall Mounted Terminations: TOP VENT

- All measurements for vertical or horizontal runs are measured from center of the vent pipe.
- Venting runs *must* fall within the limits set by the venting graph, see Figure 14.

Wall mounted Terminations

The following details are some possible configurations for Wall mounted terminations.

The Venting Graph: L42DF*

Measure the vertical height from the fireplace hearth to the centre of the termination and the horizontal run from the fireplace flue collar to the wall flange of the termination. Plot on the Venting Graph Figure 14 with an 'X'.

If the 'X' falls on or above the top boundary of the shaded area, the installation is acceptable.

Example A: (Acceptable Installation)

If the vertical dimension from the hearth is 114" and the horizontal run to the wall flange of the vent termination is 174", this would be an acceptable installation.

Example B: (Acceptable Installation)

If the vertical dimension from the hearth is 60" and the horizontal run to the wall flange of the vent termination is 42", this would be an acceptable installation.

Example C: (Unacceptable Installation)

If the vertical dimension from the floor of the fireplace is 60" and the horizontal run to the wall flange of the vent termination is 144", this would not be an acceptable installation.

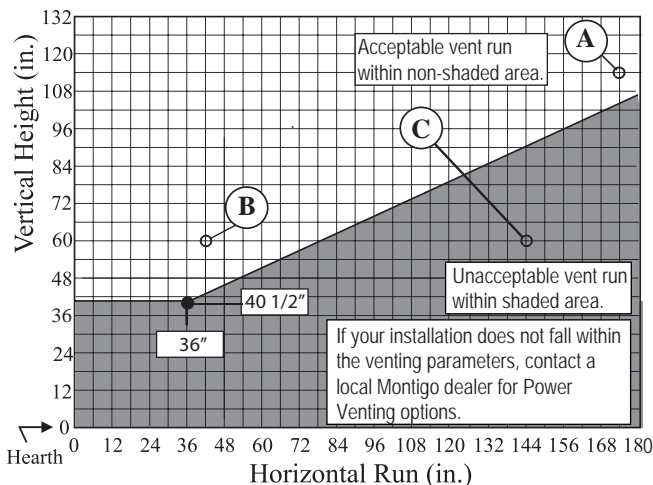

Figure 14. L42DF* Top Vent Venting Graph for wall mounted terminations.

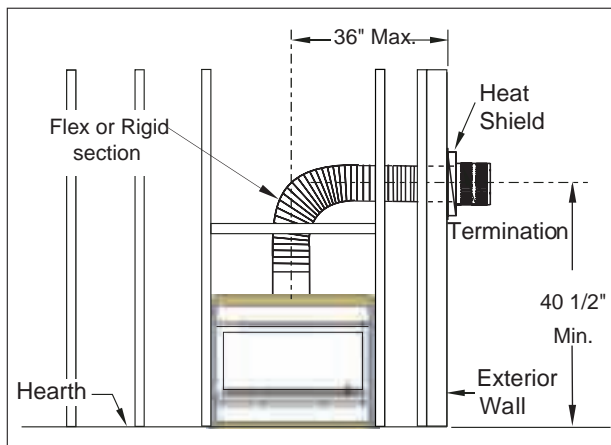

Figure 14a. Top Vented, wall mounted installation with one 90° bend. The vent run must comply with Venting Graph for Top vent, wall mounted terminations, Figure 14.

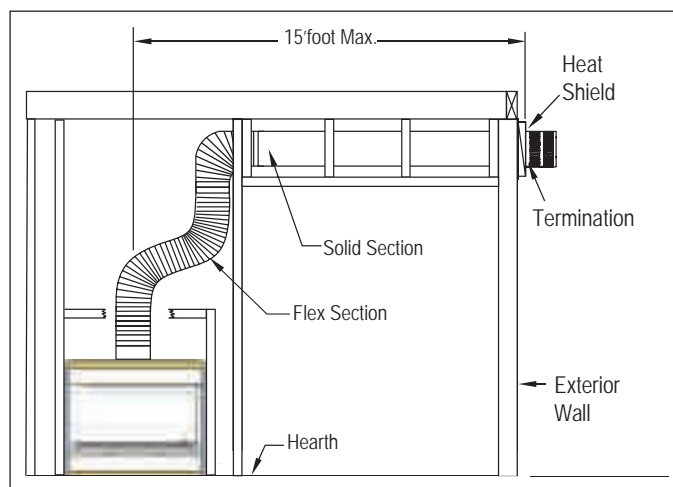

Figure 14b. Top Vented, wall mounted Multi-elbow installation. See Venting Graph for Top vent, wall mounted terminations, Figure 14.

Installation

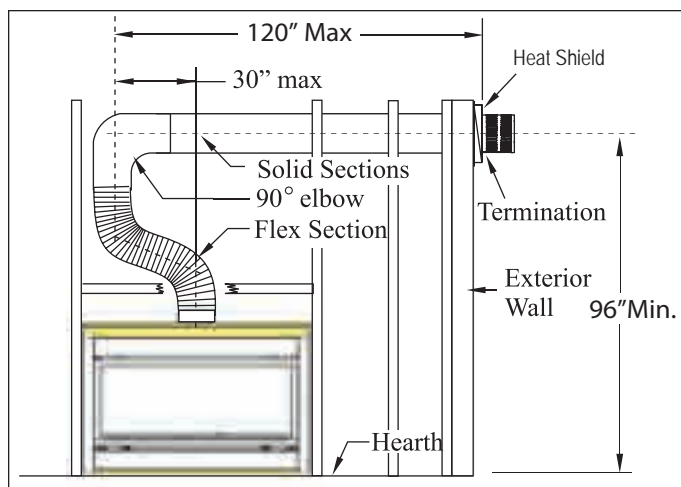

Figure 14c. Top Vented, wall mounted Retracted Multi-elbow installation. See Venting Graph for Top vent, wall mounted terminations, Figure 14.

Note: Images are shown without screens for clarity purposes. However, your fireplace should not be operated without proper installation of screens.



Installation

45° Corner Installation.

Attach an PEL-45 (45° elbow) directly onto the flue collar. Cut the PXT-20 to suit, and attach it to the PEL-45. Slide the fireplace into position and attach to the termination.

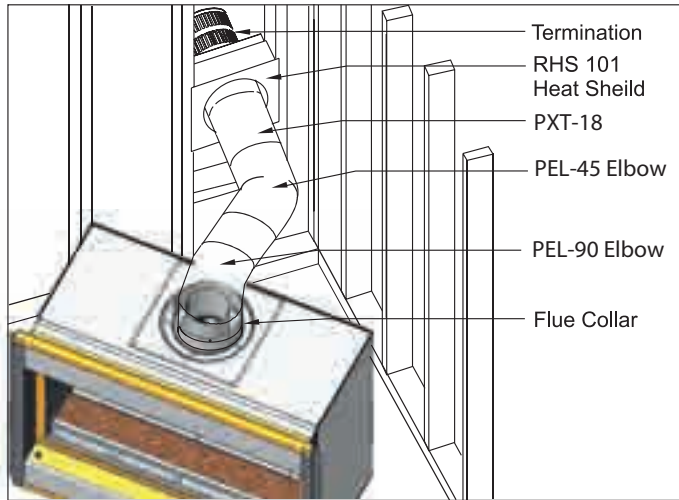

Figure 15. Corner installation.

45° or less Corner Installation.

Use an PTO-4 termination and an PFL-1 or PFL-2/PFL-2 (12" or 24" compressed length) and a frame, if appropriate. Flex may be turned to obtain desired degree of angle required but must not exceed 45°.

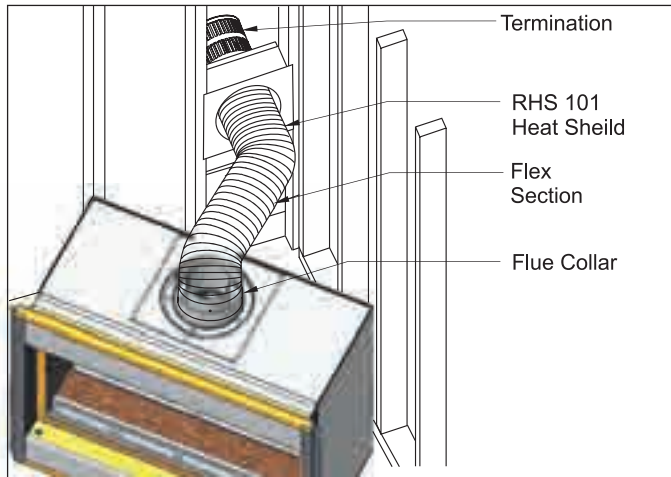

Figure 15a. Flex installation. (NG Models Only)

Note: Through the wall venting kits are also available for both the Straight and the Corner Installation. The Kit includes a heat shield, a PFL-12 (f/f) flexible pipe, and a termination with or without a mounting frame.

Installation



Notes Wall Mounted Terminations: REAR VENT

- All dimension lengths for vertical or horizontal runs are measured from center of the vent pipe.
- Venting runs must fall within the limits set by the venting graphs, see Figure 16.
- Fireplace must be converted to Rear Vent configuration prior to running vent, see Figure 10 and 10a.

The Venting Graph

Measure the vertical height from the fireplace hearth to the centre of the termination and the horizontal run from the fireplace flue collar to the wall flange of the termination. Plot on the Venting Graph Figure 16 with an 'X'.

If the 'X' falls on or above the top boundary of the shaded area, the installation is acceptable.

Example A: (Acceptable Installation)

If the vertical dimension from the hearth is 120" and the horizontal run to the wall flange of the vent termination is 138", this would be an acceptable installation.

Example B: (Unacceptable Installation)

If the vertical dimension from the hearth is 48" and the horizontal run to the wall flange of the vent termination is 96", this would **NOT** be an acceptable installation.

Example C: (Unacceptable Installation)

If the vertical dimension from the floor of the fireplace is 72" and the horizontal run to the wall flange of the vent termination is 120", this would **NOT** be an acceptable installation.

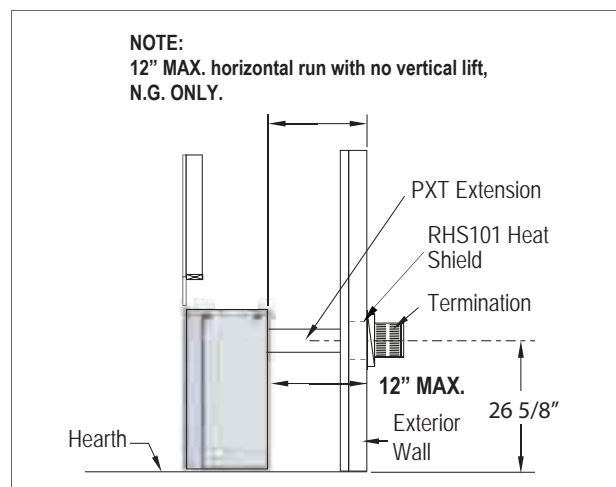

Figure 16a. Straight run, Rear Vented, wall mounted termination for L42DF*, Figure 16.

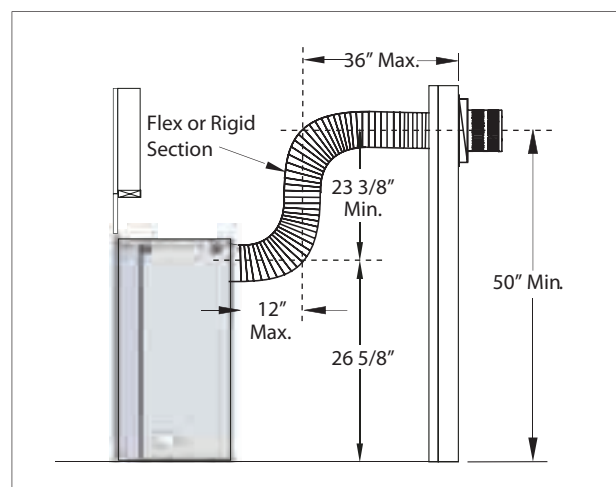

Figure 16b. Rear Vented, wall mounted Multi-elbow termination installation. Installation for L42DF* must have a minimum vertical rise of 50". The vent run must comply with the Venting Graph for Rear vent, wall mounted terminations, Figure 16.

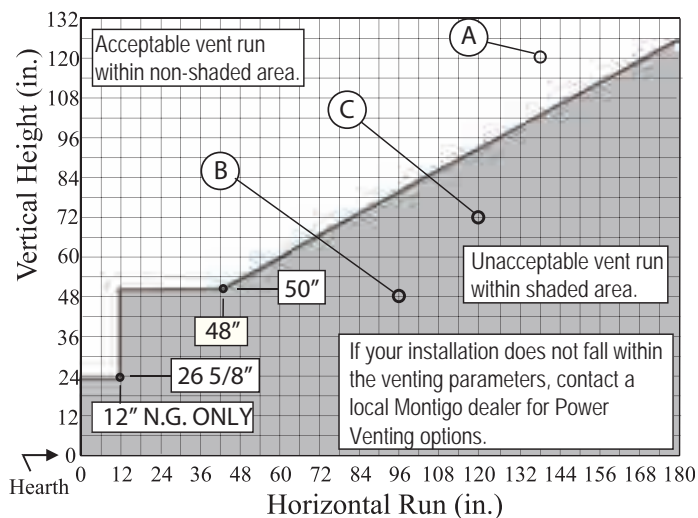

Figure 16. Rear Vent Venting Graph for wall mounted terminations.



Installation

Section 3-3-2: Venting Components

The following components and associated Montigo part numbers for installation of a roof or wall mounted termination. Use only Montigo Vent Components. Use of non-Montigo parts will VOID the warranty and may impede operation of the fireplace.

A - Termination	PTO4 (3" Length) PTO4F (3" Length) PVTK1SS
B - Frame Kits	MSR (Stucco Frame) MOSR (Stucco Frame) BSR-4 (4" Brick Frame) BSR-6 (6" Brick Frame)
C - Flex Sections	PFL - 1 (12" f/f Section) PFL - 18 (18" f/f Section) PFL - 2 (24" f/f Section) PFL - 3 (36" f/f Section) PFL - 4 (48" f/f Section) PFL - 6 (72" f/f Section)
D - Rigid Sections	PXT - 5 (5" f/f Section) PXT - 10 (10" f/f Section) PXT - 20 (20" f/f Section) PEXT - 1 (12" f/m Section) PEXT - 2 (24" f/m Section) PEXT - 3 (36" f/m Section) PEXT - 4 (48" f/m Section) PEXT - 6 (72" f/m Section)
E - Elbows	PEL-90MM (m/m 90° Elbow) PEL-90FF (f/f 90° Elbow) PEL-90FM (f/m 90° Elbow) PEL-45FM (f/m 45° Elbow)
F - Support Ring & Plate	PSPXT-8
G - Firestop	FS-8
H - Roof Flashing	PRF-7 (1/12 - 7/12 pt.) PRF-12 (7/12 - 12/12 pt.)
I - Heat Shield	RHS101
J - Heat Guard	MTKOG

Connection and installation of the vent components should adhere to the following guidelines:

- Use any combination of rigid and flex pipe as required and in any orientation (Male connectors can face in any direction).
- Flex sections may be stretched up to 50% of their total length (e.g. a 24" section maybe stretched to 36").
- Connect all vent sections using a minimum of three sheet metal screws on the outer pipe flue.
- Ensure the pipe ends male to female slide in a minimum of 1 1/2" of overlap.
- Ensure all horizontal runs are supported with a minimum of 3 supports per 10' of venting.
- When hanging/ supporting venting, ensure that 1" clearance is maintained on sides and bottom of vent runs and 2" above horizontal vent runs to any combustible material.
- Rigid pipe may be cut less than half way from the female end only.
- Ensure when cutting sections of rigid pipe to maintain integrity of internal supports.
- Place the springs, supplied with the pipe kit, between the outer and inner pipes to keep the pipes separate and avoid any possible hot spots.
- Montigo recommends the use of a flex section for the final pipe connected directly to the fireplace offering greater flexibility of installation and absorption of movement.
- Firestops must be installed as required by National & local codes.
- Montigo recommends that all exterior corners and joints be sealed with exterior caulking. However, we encourage you to consult your Building Envelope Engineer or Waterproofing Consultant for further recommendations.



IMPORTANT

Please refer to your building envelope engineer or waterproofing consultant for a review of ALL penetrations through exterior walls or the roof.

Installation



Section 3-3-3: Heat Shields

Installing a Wall Mounted RHS8 Heat shield

The RHS8 Heat shield CANNOT be used when the Termination is WITHIN (36" Min. horizontal and 46" Min. vertical) from the fireplace, or directly off the rear of the fireplace, as shown figure 17a. The RHS101 Heat Shield (Figure 18c and 18a) MUST be used within the noted dimensions.

To install the RHS8, frame an opening in combustible construction, Figure 17 below. Slide the Heat shield in place over the vent pipe which attaches to the fireplace. After the fireplace and vent pipe has been installed, clearances should match the dimensions in Figure 17.

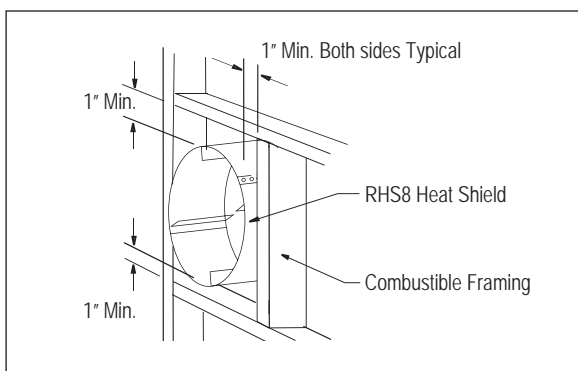

Figure 17. RHS8 Installation. (Install by sliding over vent pipe where it passes through the combustible construction).

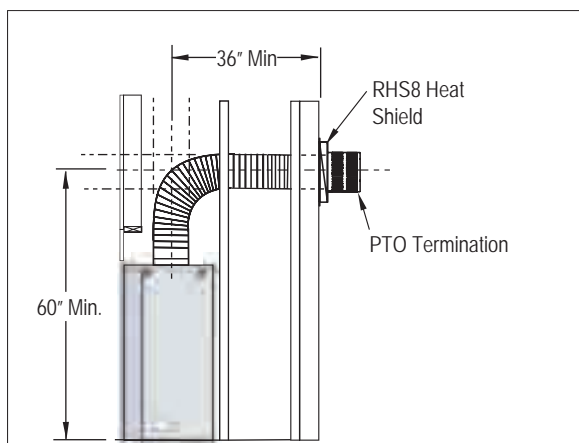

Figure 17a. RHS8 Installation. (Minimum requirements).

Note: Images are shown without screens for clarity purposes. However, your fireplace should not be operated without proper installation of screens.

Installing a Wall Mounted RHS101 Heat shield.

The RHS101 Heat shield MUST be used where the RHS8 Termination (Figure 17 and 17a) CANNOT be used. Use the RHS101 where any of the dimensions are within the parameters shown, figure 17a.

To install the RHS101, Slide the Inner Section over the vent pipe that will connect to the fireplace. Then fasten the vent pipe to the back of the fireplace with a minimum of three sheet metal screws. From the outside slide the RHS101 outer section on see Figure 18. To complete the installation fasten the Heat Shield Outer Section & Termination frame to the structure Figure 18a.

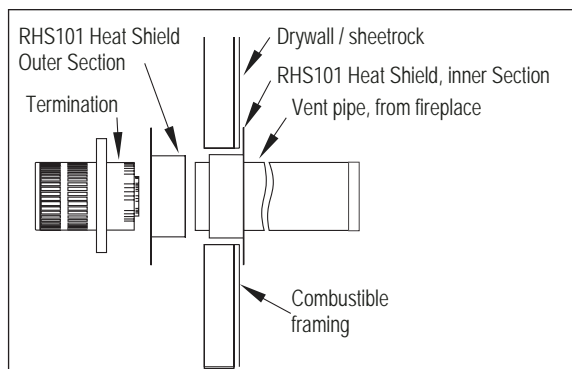

Figure 18. RHS101 Installation. (Install by sliding Outer Section over vent pipe where it passes through the combustible construction).

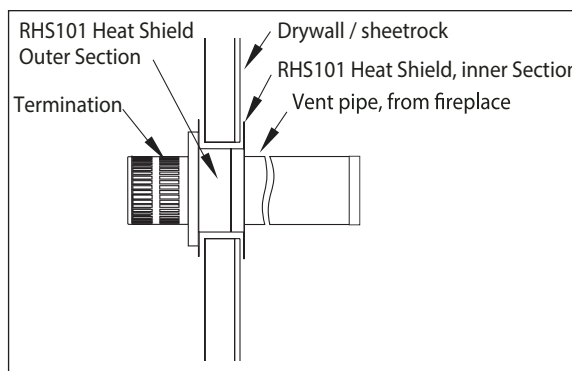

Figure 18a. Heat Shield. After sliding the outer section in place.

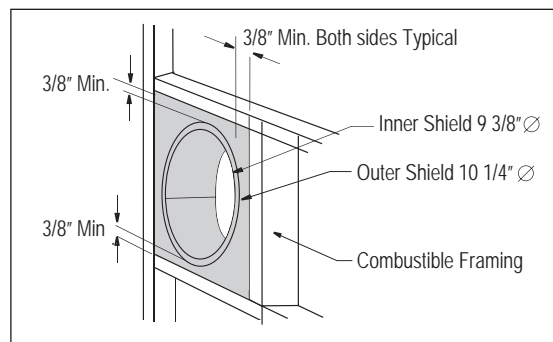

Figure 18b. RHS101 Installation.



Installation

Section 4: Wiring

Models
L42DFN-F
L42DFL-F

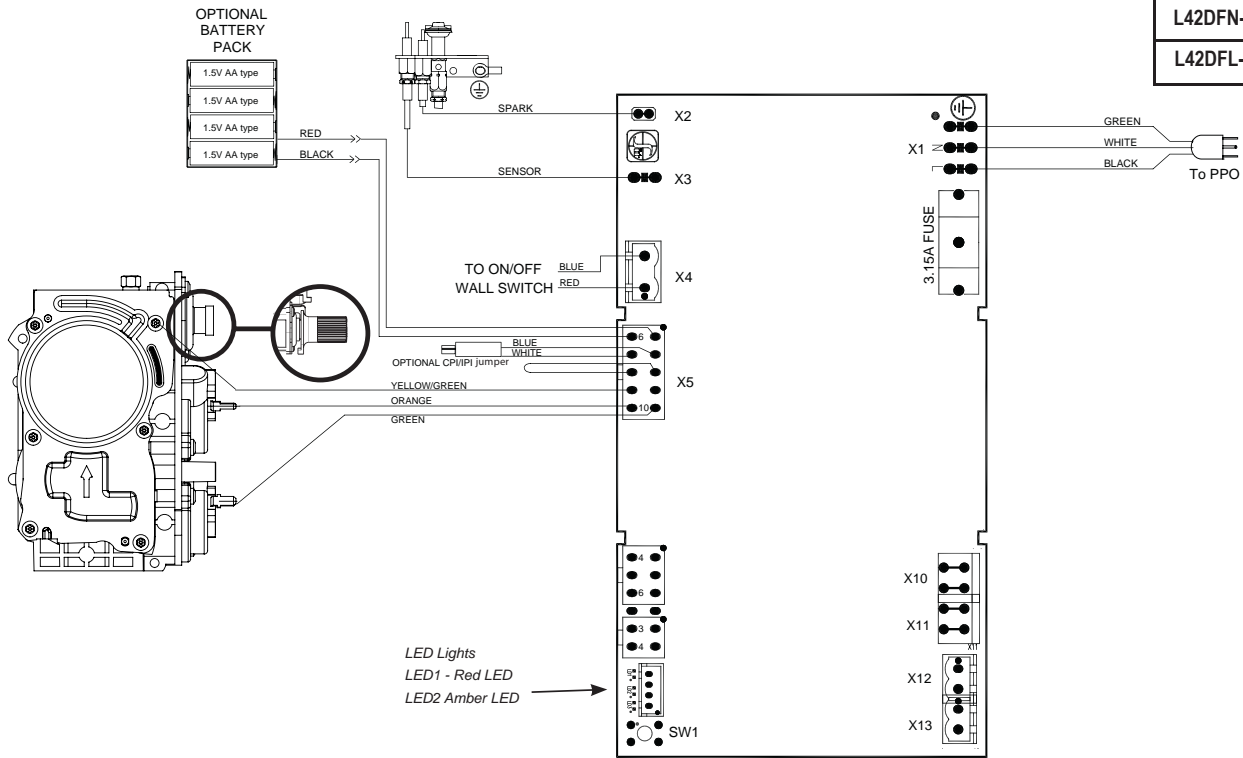

Figure 19. Wiring Diagram for the SIT Proflame 2 Electronic Ignition

Models
L42DFN
L42DFL

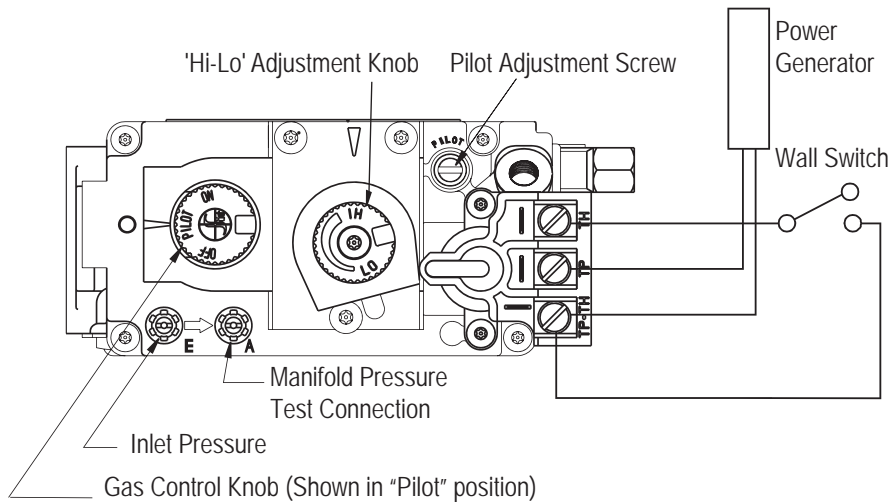

Figure 20. Wiring Diagram for SIT Nova 820 gas and pilot.

Installation



Installing the remote On/Off Wall Switch

The L42DF* gas valve may be connected to a wall switch. Do NOT connect any external power to the remote switch. The valve will generate its own power on a millivolt circuit or will draw its power from an AC Connection inside the fireplace, depending on the model of the unit. Use only low voltage wire, and DO NOT connect any external power to the remote switch.

Refer to Figure 19 or 20 for wiring requirements.

NOTE: The switch location must not exceed 30' from the fireplace.

Top / Rear Intake Air Adjustment (Electronic Ignition Only)

The L42DF* has an Intake Air Vane to modify the Incoming air. This will ensure the flame is as per the design criteria. See Figures 22 & 22a.

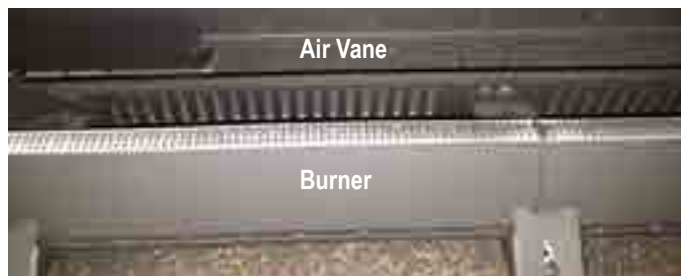

Figure 22. Closed Vane for Top Vent Fireplaces.



Figure 22a. Open Vane for Rear Vent Fireplaces.



Installation

CPI [Continuous Pilot Ignition] / IPI [Intermittent Pilot Ignition] Jumper Cable Installation (only available for SIT Electronic Ignition Systems)

“Why use CPI mode”?

CPI means “Continuous Pilot Ignition” or “Standing Pilot” as it is commonly known. IPI means “Intermittent Pilot Ignition”, which only initializes the pilot when you are going to be using the appliance.

There are several reasons why you may choose to use CPI mode. When a flue is cold it can be difficult to light the appliance. It can take a bit of time (particularly on tall vents) to initialize vent action. This can result in “lifting” or “ghosting” of the flames during the first two to three minutes of operation. It is also possible to encounter times when the fireplace fails to light successfully. The fireplace will then attempt to re-light a second or third time depending on prevailing temperatures or altitude. When in CPI mode the pilot also keeps the system warm. During a “cold” start, condensation will normally form on the inner glass surface of the door. This condensation will quickly dry, however, the condensation tends to run down the glass and cause some streaking. CPI mode helps to resolve this issue. If CPI mode is used during the winter months the energy it takes to run the pilot is partially recovered as heat into the building, so it does not waste as much energy as running a pilot in the off season.

If you use a wall switch:

A connector is supplied with this unit that can be plugged into the wire harness connected to the controller. When the CPI jumper is connected, the pilot will light and remain lit continuously. Use the wall switch to turn the main burner on or off. To switch back to IPI mode you must unplug the CPI jumper.

If you use the optional remote:

A connector is supplied with this unit that can be plugged into the wire harness connected to the controller. This Jumper Cable gives the Remote Control the ability to operate the CPI/IPI switch and set the unit to operate in either condition.

The difference between IPI and CPI:

IPI (Intermittent Pilot Ignition) Mode: is a fuel saving mode in which the pilot is only used when the main burner is on.

CPI (Continuous Pilot Ignition) Mode: The Pilot runs continuously even when the main burner is off.

Installing the CPI Jumper Cable

- 1). Remove the door and valve blind.



Figure 23.

- 2). Remove the bag containing the Jumper Cable from the wire harness connected to the controller as shown in Figure 23.



Figure 23a.

- 3). Find the corresponding plug attached to the control wire harness and connect the CPI jumper.



Figure 23b.

- 4). See operation section to turn remote into CPI mode.

Installation



Section 5: Installing the Gas Line

Section 5-1: FUEL CONVERSION

- Verify that your fireplace is compatible with your available gas type. (Natural Gas or Propane shown by "N" or "L" in your model number)
- If gas type is not compatible, contact your local Montigo representative.
- Conversion kits must be installed by a qualified service technician.

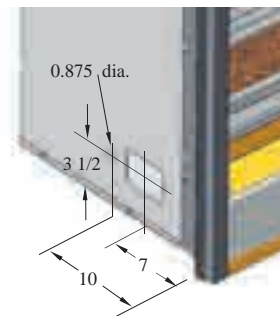

Figure 24. Gas line access.

Section 5-2: GAS PRESSURE

- Optimum appliance performance requires proper input pressures.
- Gas line sizing requirements will be determined in ANSI Z223.1 National Fuel Gas Code in the USA and CAN/CGA B149 in Canada.

Pressure requirements are:

Gas Pressure	Natural Gas	Propane
Minimum inlet pressure	5.5in. w.c.	11in. w.c.
Manifold pressure	3.5in. w.c.	10in. w.c.

- The manifold outlet pressure is set from the factory to the appropriate pressure but should be verified.
- To check pressures, control valves have a provision to remove a 1/8" N.P.T. plug to be fitted with a hose barb.
- Montigo requires a service shut off valve be located in an accessible location to isolate the gas supply.
- Only install gas shut-off valves approved for use by the state, province, or other governing body in which the fireplace is being installed.

Section 5-3: GAS CONNECTION

- See Figure 24 for location of gas line access.
- Flexible gas connectors must not exceed 3 feet in length, unless allowable within local regulations.
- Connect incoming gas line to the 1/2" or 3/8" gas inlet port.
- Purge all air out of gas line.
- Check appliance connection, valve and valve train under normal operating pressure with a commercially available leak check solution.
- DO NOT USE A FLAME OF ANY KIND TO TEST FOR LEAKS.

NOTE: After gas line is connected, each appliance connection, valve and valve train must be checked while under normal operating pressure with either a liquid solution, or leak detection device, to locate any source of leak. Tighten any areas where bubbling appears or leak is detected until bubbling stops completely or leak is no longer detected. **DO NOT** use a flame of any kind to test for leaks.

WARNING

When pressure testing the fireplace, Gas line, and input system, follow the appropriate local codes for your area. **DO NOT** connect the fireplace to pressures in excess of 1/2lbs. This will damage the gas control valve.

CAUTION

Glass doors on gas fireplaces are **extremely hot** while the fireplace is on and remain hot even after the fireplace has been turned off. Safety screens are available and can reduce the risks of severe burns. Please keep children away from the fireplace at all times.

NOTICE

Do not use ammonia based or abrasive cleaners on the glass, they will permanently etch the surface. Use an approved gas fireplace glass cleaner such as Kel-Kem or White off.

WARNING

An inspection of the explosion relief flappers and door **MUST** be made prior to lighting the fireplace. Faulty seal on the door gasket and/or explosion ports will result in combustion products leaking into the living space and may result in carbon monoxide poisoning.

WARNING

When installing the fireplace - gas lines, fittings, accessories or any other objects cannot impede the proper movement of the door buckles.



Installation

Section 6: Finishing

Finishing Around the Fireplace

Combustible mantels and mouldings may be safely installed over the top and on the front of the fireplace provided that they do not project beyond shaded area shown in Figure 25a.

Fireplace Facing

When sizing the finish material for your fireplace, it is important to remember the following: **THE OPENING MUST NOT BE OBSTRUCTED IN ANY WAY** - to do so restricts the air supply for the control compartments and heat exchanger it also prevents access for servicing controls.

The face of the fireplace may be painted to match the room decor, provided you use a heat-resistant paint. Decorative facing must not extend past the fireplace opening at all, because it will interfere with the access to retainers for removal of glass door.

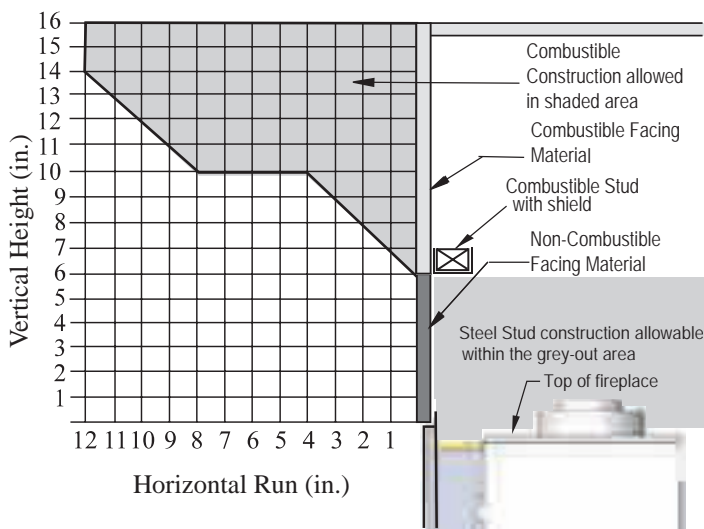

Figure 25a. Combustible mantels and facings.

⚠ IMPORTANT

When covering the upper metal portion of the fireplace, up to 6" (as shown in Figure 25) with a non-combustible material. Please note the decorative facing materials may be subject to temperatures in excess of 250°F. This should be considered when selecting facing materials.

⚠ WARNING

We recommend careful consideration be given to the effects of elevated mantel temperatures which may be in excess of product design, for example: candles, plastic, or pictures. This can cause melting, deformation, discolouration or premature failure of T.V., radio, and other electronic components.

Mantels & Surrounds

NOTE: National Canadian Gas Association mantel test requirements are for fire hazard prevention to combustible materials.

New technology, to meet consumer and government demands for the wise use of energy, has prompted us to manufacture many models of fireplaces which are hot, fuel and energy efficient.

Please be aware; temperatures over the mantel will rise above normal room temperature and walls above fireplace may be hot to touch.

Side wall clearances are 3". Combustible surrounds may be installed with 3" clearance to the side of the fireplace as shown in Figure 25b.

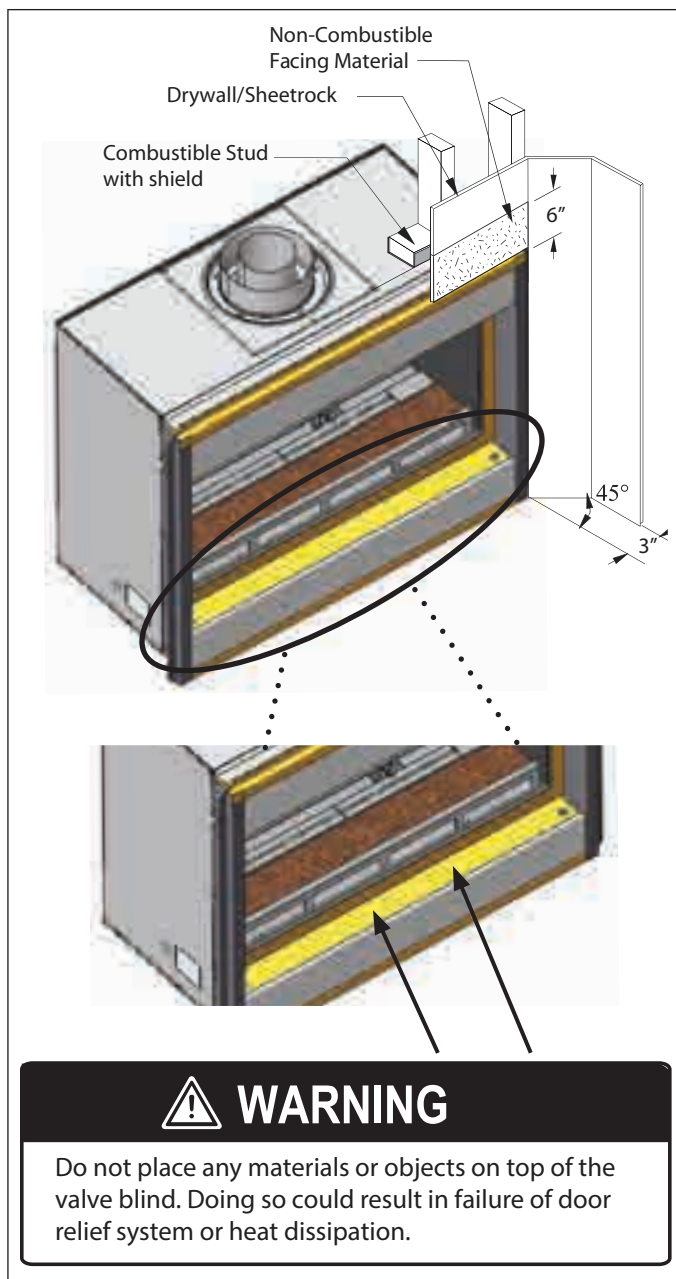

⚠ WARNING

Do not place any materials or objects on top of the valve blind. Doing so could result in failure of door relief system or heat dissipation.

Figure 25b. Combustible surrounds.

Installation



Section 7: Screen Installation and Removal

Removing / Attaching Screens:

To Remove Screens:

Grasp each top outer corner of the screen with your thumb and finger and pull towards yourself. When the upper Screen Studs are free, lift the screen at an angle from the lower slots from which the Screen Bottom Tabs are held. Place the screen in a safe place.

To Install Screens:

Hold the screens at an angle away from the fireplace, and locate the Screen Bottom Tabs at the lower corners of the screen. Place the screen into the Screen Tab Receptacles in the lower section of the fireplace.

Make sure the tabs and screens are lowered all the way down into the Screen Tab Receptacles on the fireplace. Then, push each Upper Screen Stud on the top corners of the screen into the Upper Screen Stud Receptacles in the fireplace.

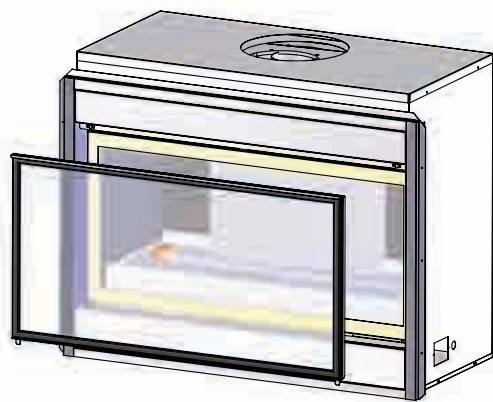

Figure 26a. Screen Door Numbers (Replacement Parts)

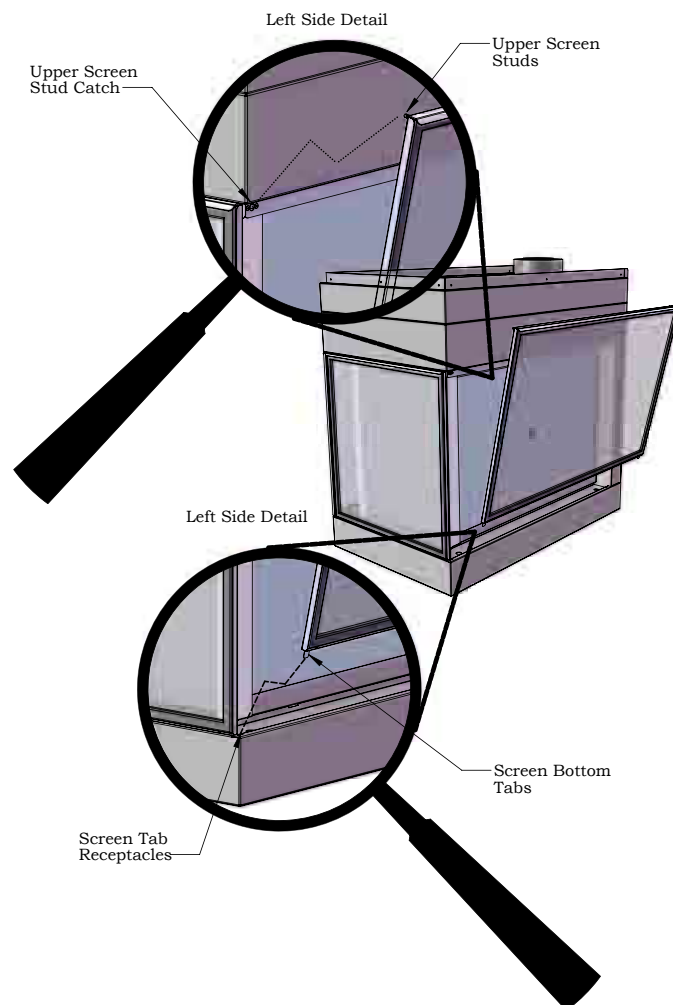

Figure 26b. Screen Installation and Removal

Replacement Screens:

For replacement part order numbers, please refer to section "Replacement Parts:" on page 37

Note: Do not operate fireplace without all screens in place.



Installation

Section 8: Installing & Removing the Door

Removing the door:

The L42DF* door is removed in a few simple steps. Follow these instructions below to remove the Horizontal access panel, unlatch the door buckles and, remove the door. Replace in reverse order.

WARNING

When reinstalling door(s), always make sure all door buckles are properly hooked and fully engaged.

Step 1:

Remove the Horizontal cover by placing fingers in both finger holes, then pushing away from you and lifting out. Place it aside during maintenance or cleaning. Install in reverse order.



Figure 27. Removing and installing the Horizontal Access Panel

Step 2: Locate the Door Buckles.

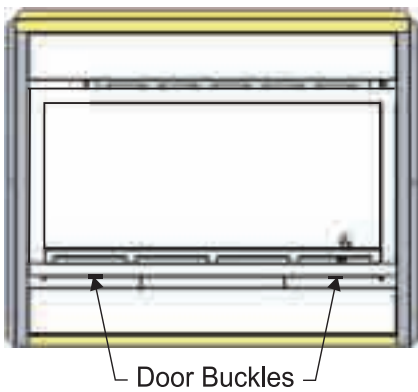

Figure 27a. Door buckle locations.

Step 3: Locate Door Buckle Tool.



Figure 27b. Door buckle Tool

Step 4:

Firmly grasp hand-hold end of Door buckle tool and place the machined end in the slot under door frame. (as shown)

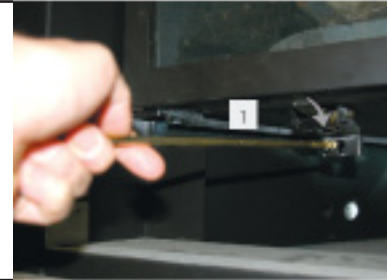

Figure 27c.

Step 5:

Ensure the tool is firmly in the lower end of the slot, (as shown), Then pull toward you (Caution: hold the tool securely).

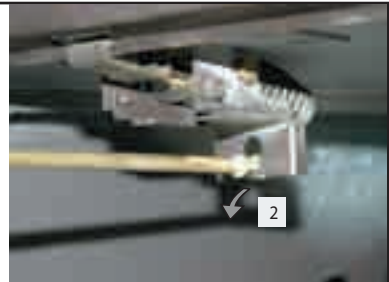

Figure 27d.

Step 6:

Pull hard if necessary to release the spring tension. (Caution: The latch springs back with force, hold the tool securely).

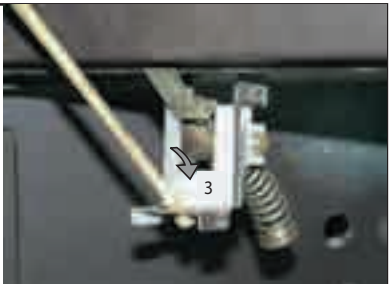

Figure 27e.

Step 7:

Remove the tool from the latch slot. Ensure the latches are hanging freely, the hook end is released from the bottom of the door. (Repeat all 4-steps for the remaining latches).



Figure 27f.

Installation



Step 8: Removing the Door:

Grasp the Door on either side, usually midway and lift upward, lift the door carefully up and away from the front of the fireplace. See Figures 27g. Place the Door aside in a safe place while maintenance and/or cleaning is being performed.

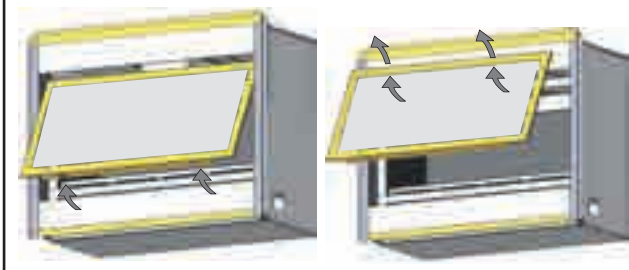

Figure 27g. Removing and installing the glass doors.

Installing the Door:

To install the door, hook the top edge of the door frame into place. Lower the door into position and follow the previous steps shown in reverse order.

WARNING

When installing the fireplace - gas lines, fittings, accessories or any other objects cannot impede the proper movement of the door buckles.

Installing Firestones in Natural Gas and Propane Fireplaces

The L42DF* fireplace is supplied with firestones. Remove the glass door. Follow these instructions to ensure all parts are removed or replaced as required. Once the glass door is removed place the firestones randomly across the pan as described in Figure 28 to 28a.

WARNING

DO NOT COVER THE BURNERS or PILOT



Figure 28. Completed firestone installation. Second Gen burner shown.

(Note: DO NOT place ANY firestones on top of the burners or pilot).



Figure 28a. Operating gas fireplace with firestones surrounding burner tray. Second Gen burner shown.

Optional Cultured Rocks

The L42DF* has the option of installing the cultured rocks which mimic real stone. These may be spaced at random or in a visual pattern of your preference in the burner tray. See the Montigo web site for photographs and ideas. www.montigo.com



Operation

Section 9: Start-up Sequence



For Your Safety - READ BEFORE LIGHTING:



- This appliance is equipped with an ignition system that lights the pilot burner automatically. Do not attempt to light the pilot by hand.
- BEFORE LIGHTING** smell all around the appliance area for gas. Be sure to smell next to the floor because some gas is heavier than air and will settle on the floor.
What To Do If You Smell Gas:
 - Do not try to light any appliance.
 - Do not touch any electrical switch; do not use any phone in your building.
 - Immediately call your gas supplier from a neighbour's

Standing (Continuous) Pilot Ignition (SIT NOVA 820)

Lighting Instructions:

- STOP!** Read the safety information above on this label.
- Lift out the lower Horizontal access panel.
- Push in gas control knob and turn clockwise  to "OFF."
- Wait five (5) minutes to clear out any gas. Smell for gas, including near the floor. If you then smell gas, **STOP!** Follow "B" in the safety information above on this label. If you don't smell gas, go to the next step.
- Locate pilot burner (*See illustration at right.*) and follow steps below.
- Turn knob on gas control counter-clockwise  to

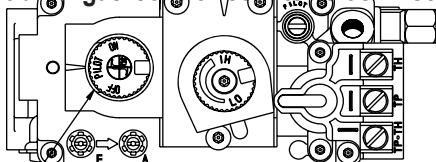

Gas Control Knob
(Shown in "Pilot" position.)
NOTE: Gas control knob cannot be turned from "PILOT" to "OFF" unless knob is pushed in slightly. Do not force.

WARNING

If the information in these instructions is not followed exactly, a fire or explosion may result causing property damage, personal injury or death.

WARNING/ CAUTION: Hot while in operation. Do not touch. Severe burns may result. Keep children, clothing, furniture, gasoline and other liquids having flammable vapours away.

See installation and operating instructions accompanying this appliance.

phone. Follow the gas supplier's instructions.

- If you cannot reach your gas supplier, call the Fire Department.
- Use only your hand to push in or turn the gas control knob. Never use tools. If the knob will not push in or turn by hand, don't try to repair it, call a qualified service technician. Force or attempt to repair may result in a fire or explosion.
 - Do not use this appliance if any part has been under water. Immediately call a qualified service technician to inspect the appliance and to replace any part of the control system, and any gas control which has been under water.

"PILOT."

- Push in gas control knob completely and hold. Light with Piezo Igniter button. Continue to hold the control knob in for about (1) minute after the pilot is lit. Release the knob and it will pop back up. Pilot should remain lit. If it goes out repeat steps 3 through 8.
 - If knob does not pop up when released. Stop and immediately call your service technician or gas supplier.
 - If the pilot will not stay lit after several tries, turn the gas control knob to "OFF" and call your service technician or gas supplier.
- Push in gas control knob and turn counter-clockwise  to "ON."
- Replace the lower Horizontal access panel.
- Turn on remote switch to ignite fire.

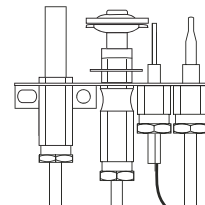

To Turn Off Gas To Appliance:

- Turn off remote switch.
- Lift out the lower Horizontal access panel.
- Push in gas control knob slightly and turn  clockwise to "Off". Do not force.
- Replace the lower Horizontal access panel.

Operation



SIT Proflame 2 Electronic Ignition

Lighting Instructions:

1. STOP! Read the safety information above on this label.
2. Remove the lower Horizontal access panel.
3. Turn "ON" manual "ON/OFF" switch located below the horizontal access panel (if available).
4. Turn Incoming gas valve to the "ON" position.
5. Wait 5 minutes to clear out any gas. If you smell gas, STOP! Follow "B" in the safety information above on this label. If you don't smell gas, go to the next step.
6. Turn fireplace "ON" using wall switch or remote control.
7. If the Fireplace does not light, the System will cycle through two trials, (one minute audible clicking, thirty seconds of silence, and then another one minute of audible clicking). If the system locks out due to inadequate gas flow, refer to "Troubleshooting" in instruction guide.
8. After completion of the information in the Troubleshooting section, Repeat step 5.
9. If the system will not function correctly, follow the instructions "To Turn Off Gas To Appliance" and call your service technician or gas supplier.

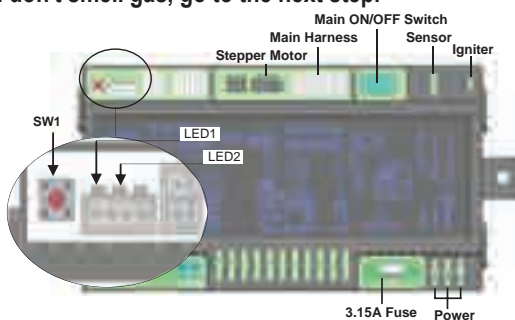

SW1 = Programing Button
 LED1 = Red Diagnostic Light
 LED2 = Amber Programing Remote Control Light
 Typical Control Module shown

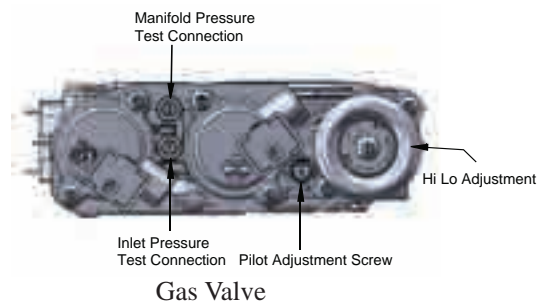

To Turn Off Gas To Appliance:

1. Turn off fireplace using wall switch or remote control.
2. Remove the lower Horizontal access panel.
3. Turn the incoming gas control valve to "Off".
4. Replace the lower Horizontal access panel.



Operation

Section:

Optional Remote Operation

The Proflame 2 System consists of the following elements:

1. Pilot Assembly
2. Proflame Gas Valve.
3. Proflame 2 Control Module
4. Wiring Harness
5. Variable Speed fans
6. Variable Accent Lights
7. Proflame 2 remote control
8. Battery Pack
- 9 Manual override switch

NOTE: Can not be used with home automation systems.

The Proflame 2 Transmitter controls the following fireplace functions:

1. Main Burner On/Off
2. Main Burner flame modulation (6 levels).
3. Choice of standing or intermittent pilot (CPI/IPI).
4. Thermostat and Smart thermostat functions.
5. Variable Accent light (6 Levels).
6. Fan speed modulation (6 levels).

The Proflame 2 Transmitter uses a streamlined design with a simple button layout and informative LCD display. A Mode Key is provided to index between the features and a Thermostat Key is used to turn On/Off or index through Thermostat functions, see Figure 29. Additionally, a Key Lock feature is provided.



Figure 29.

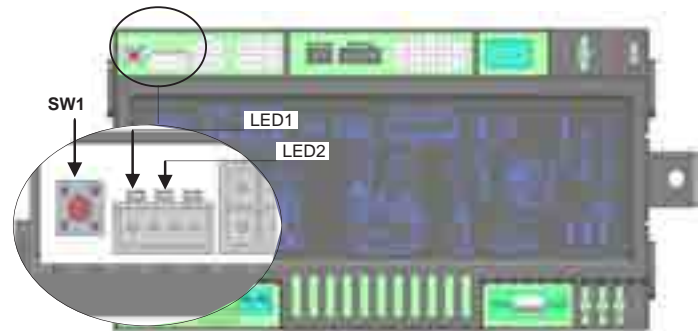

- SW1 = Programing Button
- LED1 = Red Diagnostic Light
- LED2 = Amber Programing Remote Control Light

Figure 29a. Proflame 2 Control Module

⚠ WARNING

Do not expose remote control to temperatures below 0°C (32°F) or above 50°C (122°F)

⚠ CAUTION

Property Damage Hazard. Excessive heat can cause property damage.
The appliance can stay lit for many hours. Turn off the appliance if it is not going be attended for any length of time.

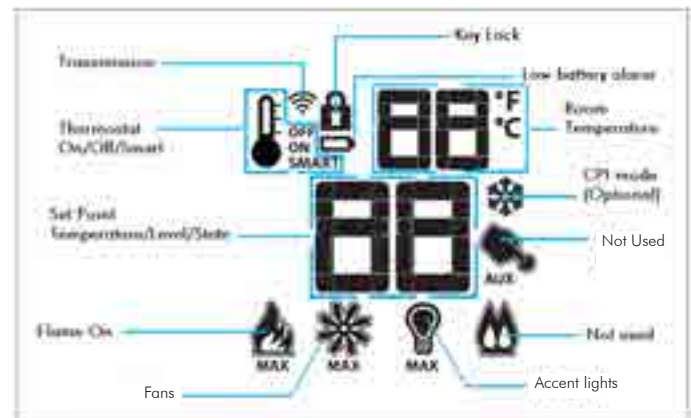

Figure 29b. Remote Control LCD Display

Operation



Section:

Initializing the System for the first time

1. Set master override switch to off position.
2. Install four (4) AA batteries into the battery holder.
3. Install three (3) AAA batteries in the back of the remote control.

Note the polarity of batteries and install them as indicated by the silk screen (+/-) on the holder.

4. Connect AC Power (115 volts, 60 Hz) to fireplace.

Operating the System for the first time

5. Press SW1 button on the control module. The control module will beep three (3) times and an amber LED is illuminated to indicate that the IFC is ready to synchronize with a remote control within 10 sec. Push the ON button. The control module will "beep" four (4) times to indicate transmitter's command is accepted.

The System is now initialized.

Temperature indication Display

With the system in the "Off" position, press the Thermostat Key and the Mode Key at the same time. Look at the LCD screen on the Remote Control to verify that a C or F is visible to the right of the Room Temperature display.

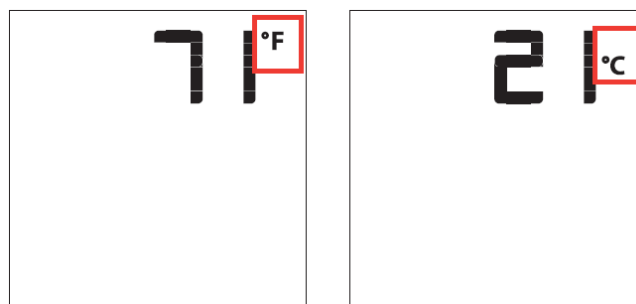

Figure 29d. Remote Control display in Fahrenheit & Celsius.



WARNING

Battery operated device. Read the battery instructions before installing them into the system. Do not expose any battery, or its holder, or a device in which batteries are installed, to a working temperature greater than 54°C / 129°F.



Figure 29c. Remote Control Battery Compartment

Turn On the Fireplace

With the system Off, turn the master override switch to on and press the On/Off Key on the Remote Control. The Remote Control display will show some other active icons on the screen. At the same time the Control Module will activate the fireplace. A single "beep" from the Control Module will confirm reception of the command.

Turn Off the Fireplace

With the system On, press the On/Off Key on the Remote Control. The Remote Control LCD display will only show the room temperature. At the same time the Control Module will turn off the fireplace. A single "beep" from the Receiver confirms reception of the command.



Figure 29e. Remote Control Display



Operation

Section: Remote-Flame Control

When you turn on the fireplace it starts on high. The proflame 2 has six (6) flame levels. Each time you press the Down Arrow Key once the flame height will reduce by one step.

You can continue this until the main burner flame turns off. You can still operate the accent lights and fans in this mode.

If the main burner flame is off and you press the up arrow key once, the flame will automatically go to high.

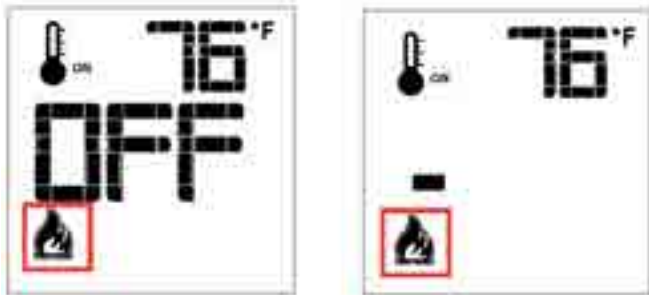

Figure 29f. Flame Off and Flame Level 1.

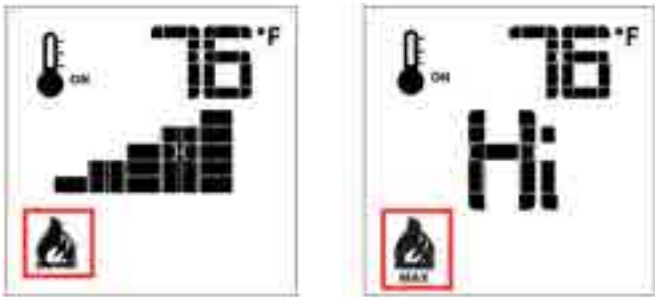

Figure 29g. Flame Level 5 and Flame Level Maximum.

Room Thermostat (Remote Control Operation)

The Remote Control can operate as a room thermostat. The thermostat can be set to a desired temperature to control the comfort level in a room. To activate the function, press the Thermostat Key, see Figure 29h. The LCD display on the remote control will change to show that the room thermostat is "On" and the set temperature is now displayed. To adjust the set temperature press the Up or Down Arrow Keys until the desired set temperature is displayed on the LCD screen of the Transmitter.

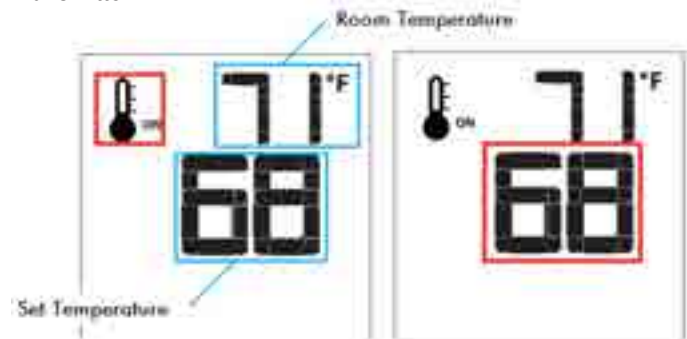

Figure 29h. Setting Room Thermostat

Smart Thermostat (Remote Control Operation)

The Smart Thermostat function adjusts the flame height in accordance to the difference between the set point temperature and the actual room temperatures. As the room temperature gets closer to the set point the Smart Function will modulate the flame down. To activate the function, press the Thermostat Key, see Figure 29, until the word "SMART" appears to the right of the temperature bulb graphic, see Figure 29i.

NOTE: When smart Thermostat is activated, manual flame height adjustment is disabled.

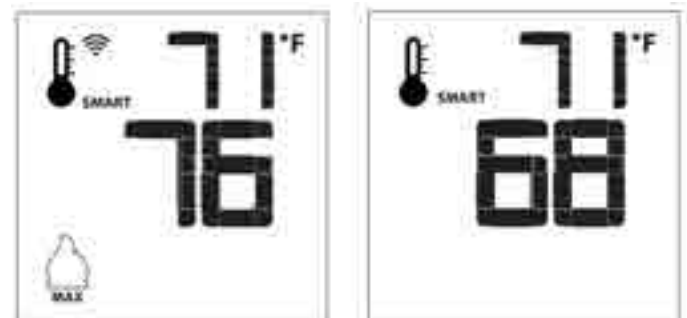

Figure 29i. Smart flame function

Operation



Disabling Thermostat

Some jurisdictions and bedroom installations require the thermostat to be disabled.

1. Partially take out one battery, see Figure 29j.
2. Insert the battery while holding down the thermostat button. The remote screen will display 'Clr' while the button is held down. See Figure 29k.
3. To enable thermostat repeat steps 1-2. The remote screen will display 'set' while the thermostat button is held down.



Figure 29j.



Figure 29k.

Fan Speed Control

The fireplace is equipped with optional hot air circulating fans. The speed of the fans can be controlled by the Proflame system. The fan speed can be adjusted through six (6) speeds. To activate this function use the Mode Key, see Figure 29, to index to the fan control icon, see Figure 29l. Use the Up/Down Arrow Keys to turn on, off, or adjust the fan speed. A single "beep" will confirm reception of the command.

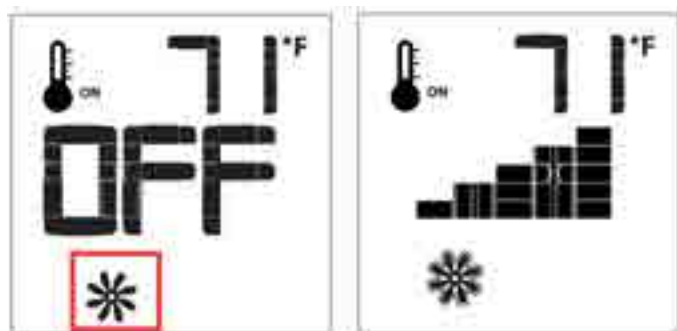

Figure 29l. Fan Speed Control

Accent Light Control

If the fireplace is equipped with variable accent lights. The accent light function controls the Accent Lights. To activate this function use the Mode Key, see Figure 29, to index to the accent light icon, see Figure 29m.

Pressing the Up Arrow Key will turn the light on at the lowest setting. Continue pressing up to get brighter. Pressing the Down Arrow Key will turn the lights down until you get to the off position. A single beep will confirm the reception of the command.

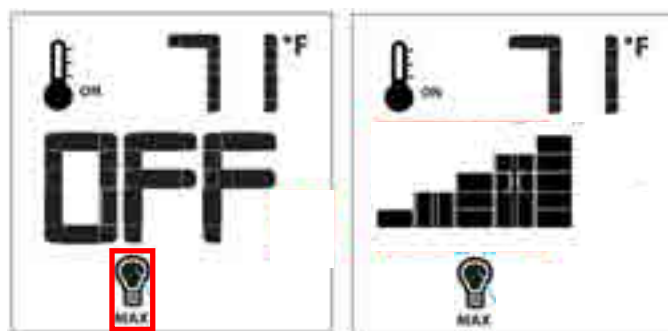

Figure 29m. Light Control



Operation

Section:

Continuous Pilot (CPI) Selection (Optional)

In cold weather climates, the pilot burner can stay on continuously to prevent condensation or cold air temperatures near the fireplace glass. Note, some jurisdictions do not permit use of continuous pilot system. Check local codes or contact your Montigo dealer.

With the system in "off" position press the Mode Key, see Figure 29, to index to the CPI mode icon, see Figure 29n. Pressing the Up Arrow Key will activate the Continuous Pilot Ignition mode (CPI). Pressing the Down Arrow Key will return to IPI. A single "beep" will confirm the reception of the command.

NOTE:

- Requires CPI/IPI jumper cable installed, see page 22.

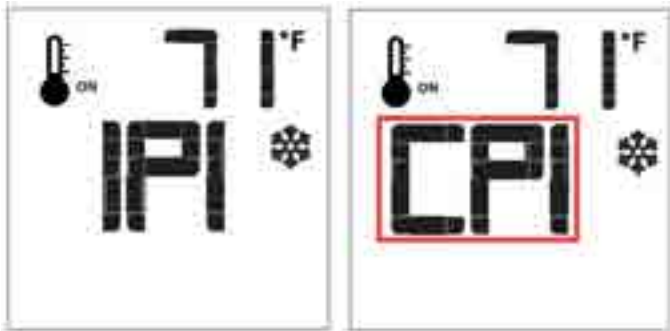

Figure 29n. Continuous Pilot / Intermittent Pilot Selection

Key Lock

This function will lock the keys to avoid unsupervised operation. To activate this function, press the Mode and Up Keys at the same time, see Figure 29o. To de-activate this function, press the Mode and Up Keys at the same time.



Figure 29o. Key Lock

Low Battery Power Detection

The life span of the batteries depends on various factors: quality of the batteries used, the number of ignitions of the appliance, the number of changes to the room thermostat set point, etc.

Remote Control

When the Remote Control batteries are low, a Battery Icon will appear on the LCD display of the Remote Control, see Figure 29p, before all battery power is lost. When the batteries are replaced this icon will disappear.

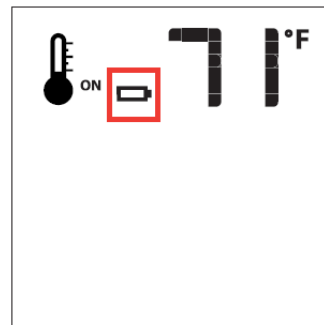

Figure 29p. Low Battery Power Detection

Control Module

When the back-up batteries are low, a "double-beep" will be emitted from the IFC when it receives an On/Off command from the Remote Control. This is an alert for a low battery condition of the receiver and after that no more commands will be accepted. When the batteries are replaced the "beep" will be emitted from the receiver as soon as powered.

Maintenance



Maintenance

Lighting Instructions See pages 28 to 29.

General

Have the fireplace and installation inspected yearly. The inspection must include, but is not limited to, the following:

- A visual check of the entire vent system and termination.
- An inspection of the explosion relief flappers and the door gaskets to ensure a proper seal.
- An inspection of the burner, vent run, and primary air openings.
- An inspection of the gas valve, gas components, and pilot flame. For your convenience a 1/8" manifold pressure tap is supplied on the gas valve for a test gauge connection.
- Inspection of all optional equipment; fans, thermostats, etc.
- For Natural Gas this appliance requires a minimum inlet pressure of 5.5" W.C. and a manifold pressure of 3.5" W.C.
- For Propane Gas this appliance requires a minimum inlet pressure of 11" W.C. and a manifold pressure of 10" W.C.
- Always keep the fireplace area clear and free of combustible materials, as well as gasoline and other flammable vapors and liquids.
- Do not use this appliance if any part has been under water. Immediately call a qualified service technician to inspect the appliance and to replace any part of the control system and any gas control which has been under water.
- Inspection of glass doors and screen for damage and proper installation.

Cleaning

When the fireplace is first activated, there may be some smoke and a visible film may be left on the glass. This is a normal condition, and is the result of burning of protective coatings on new metal.

- Glass must be cleaned periodically to remove any film (which is a normal by-product of combustion) which may be visible. Film can easily be removed by removing the door, as shown on Page 23. Handle the door carefully, and clean it with non-abrasive glass cleaners. One of the most effective products is Kel Kem.
- Silicone seals on inner door during initial firing will "off gas", leaving a visual deposit of a white substance on combustion chamber walls. This can easily be removed from the chamber walls using normal household products.
- Use a vacuum cleaner or whisk broom to keep the control compartment, burner, and firebox free from dust and lint.

Hi-Lo Burner Adjustment: (SIT Nova 820).

The L42DF* is equipped with an adjustable burner, allowing you to raise or lower the flames. To adjust the flames, locate the black knob marked 'Hi-Lo', in the centre of the gas control valve (See Figure 30).

- To raise the flame height, turn the black knob (located behind the lower control compartment) counter-clockwise.
- To lower the flame height, turn clockwise.

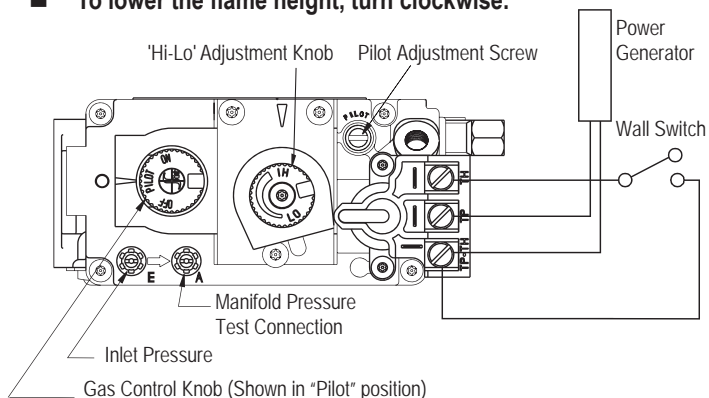

Figure 30. 'Hi-Lo' Adjustment on the SIT Nova 820 gas valve,

Hi-Lo Burner Adjustment: (SIT Proflame 2).

The L42DF* is equipped with an adjustable burner, allowing you to raise or lower the flames. To adjust the flames, locate the black knob marked 'Hi-Lo', in the centre of the gas control valve (See Figure 31).

- To raise the flame height, turn the black knob (located behind the lower control compartment) counter-clockwise.
- To lower the flame height, turn clockwise.

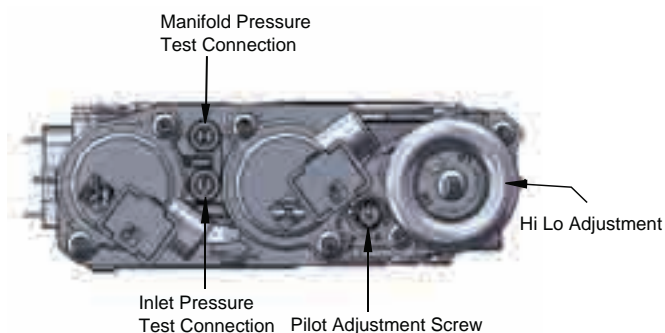
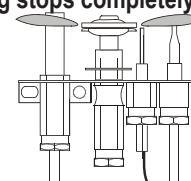

Figure 31. 'Hi-Lo' Adjustment on the SIT Proflame gas valve.

Pilot Burner Adjustment.

1. Locate Pilot Adjustment Screw. (See figure 30 or 31.)
2. Adjust pilot screw to provide properly sized flame as shown.
3. After installing or servicing, leak test with a soap solution with main burner on. Coat pipe and tubing joints, gasket etc. with soap solution. Bubbles indicate leaks. Tighten any areas where the bubbles appear until the bubbling stops completely.





Maintenance

Troubleshooting

SIT Nova 820:

The following is a troubleshooting chart of possible problems:

PROBLEM	SOLUTION
Noisy Pilot Flame	Locate pilot adjustment screw on gas control valve. Flame is decreased by turning adjustment screw clockwise.
Pilot won't ignite	Disconnect remote wires and try to light pilot. If pilot now works, remote connections are faulty. Check wiring diagram figure 30.
Main burner will not ignite	1. Check wiring (see figure 30). 2. Check wall switch for proper connection.

SIT Proflame 2:

The following is a troubleshooting chart of possible problems:

PROBLEM	SOLUTION
Pilot Igniter won't spark	1. Check the MAIN ON-OFF switch (typically located below the valve cover) and turn ON 2. Ensure main power is ON or new batteries are installed in the remote control and backup battery pack (if available). 3. Check the 3.15A fuse in the control box and replace if necessary
Pilot Igniter sparking, but Pilot burner will not light	1. Verify the Inlet and Manifold Gas Pressure are within acceptable limits 2. Check all connections to gas valve 3. Check connection to stepper motor (if available)
Pilot lights , but Main burner will not Light	1. Check and verify all wiring connections as per the wiring diagram. 2 . Verify the inlet and Manifold Pressure are within acceptable limits
Pilot lights , but Main burner will not Light and igniter continues to spark	1. Check the Pilot Flame Sensor Rod and clean with steel wool or similar. 2 . Check the Pilot hood and clean with steel wool if dirty. 3. Adjust pilot flame using the pilot adjustment screw if the pilot flame is too long or too short (Flame should fully engulf the sensor rod and must be stable). 4. Check and make sure the ground wire from the pilot is connected to the fireplace body.
Fans not working	1. Ensure main power is ON (fireplace may be operating on back up batteries). 2. Check the 3.15A fuse in the control box and replace if necessary

If your fireplace still does not operate correctly, consult your local Montigo dealer.

All service and repairs should be performed by a qualified Technician.

All spare parts, optional fans, and optional trim finishes are available from your local Montigo dealer.

Replacement Parts



Replacement Parts:

Standing Pilot - Replacement Parts List	
	L42DF
NG Gas Valve	RGC1006
LP Gas Valve	RGC1005
NG Pilot	RPA020
LP Pilot	RPA021
NG Burner	Contact Local Montigo Dealer
LP Burner	
Thermocouple	RTC182
Thermopile	RPG001
Piezo Ignitor	PIEZO
Pilot Tubing	RPTA03
Door	RDTL42
Replacement Screen	RSCP42

SIT IPI Proflame 2 - Replacement Parts List	
	L42DF
NG Gas Valve (Hi Low)	RGC3044
LP Gas Valve (Hi Low)	RGC3045
NG Gas Valve (with stepper motor)	RGC3033
LP Gas Valve (with stepper motor)	RGC3034
NG Pilot Assembly	RPA035
LP Pilot Assembly	RPA036
Ignitor Probe Assembly	RGC3075
Flame sensor rod assembly	RGC3076
Pilot Tubing	RPTA03
Door	RDTL42
Control Module	RGC3095
Proflame Transmitter	RGC3063
Replacement Screen	RSCP42

Appendix

Appendix A: Venting Terminations

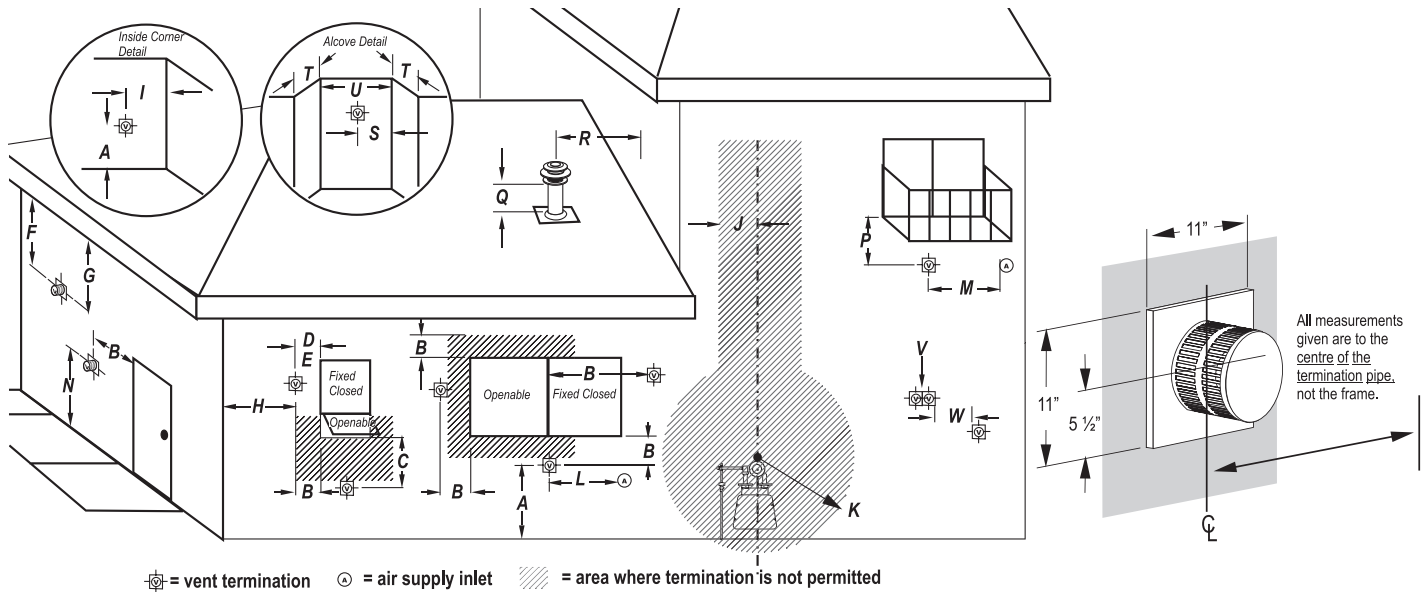

Location	Canada*	USA**
A clearance to the termination frame above grade, veranda, porch, deck, or balcony	12 inches	12 inches
B clearance to top of doors or operable windows	12 inches	12 inches
C clearance to sides or bottom of door or operable windows	12 inches	9 inches
D clearance to permanently closed window when installed with approved glass penetration termination	0	0
E clearance to permanently closed window Recommended to prevent condensation	16 inches	16 inches
F clearance to ventilated soffit located within a horizontal distance to 24 inches from centerline of termination	22 inches	22 inches
G clearance to unventilated soffit	30 inches to combustibles 16 inches to non-combustibles	30 inches to combustibles 16 inches to non-combustibles
H clearance to outside corner	9 inches	9 inches
I clearance to inside corner	12 inches	12 inches
J clearance to each side of the vertical centerline of a metre or regulatory assembly to a maximum vertical distance of 15ft	3 feet	3 feet
K clearance to service regulator vent outlet	3 feet	3 feet
L clearance to non mechanical air supply inlet to the building or combustion air inlet to other appliance for appliance <= 100,000 BTU/H (30 KW)	12 inches	12 inches
M clearance to forced air supply inlet	6 feet	3 feet above air inlet
N clearance above paved sidewalk or paved driveway located on public property	7 feet	7 feet
P clearance under veranda, porch, deck, or balcony	22 inches to combustibles 16 inches to non-combustibles	22 inches to combustibles 16 inches to non-combustibles
Q clearance above roof	2 feet	2 feet
R clearance to adjacent walls and neighboring buildings	2 feet	18 inches
S clearance from corner in recessed location	12 inches	12 inches
T Maximum depth of recessed location	4 feet	4 feet
U Maximum width for back wall of recessed location	2 feet	2 feet
V Horizontal clearance between two terminations that are level	0	0
W Horizontal clearance (centre to centre) between two terminations that are not level	18 inches	18 inches

Note 1: For N a vent shall not terminate directly above the sidewalk or paved driveway which is located between two single family dwellings and serve both dwelling.

Note 2: For P only permitted if veranda, porch, deck, or balcony is fully open on a minimum of two sides beneath the floor

Note 3: For J, K, and as specified in CGA B149 installation code. Local codes or regulations may vary.

* Based on CGA B149.1 Natural Gas and Propane installation code. Local codes may vary, please check with local regulatory agency.

** Based on ANSI Z223.1/NFPA 54 National Fuel Gas Code. Local codes may vary, please check with local regulatory agency.

Appendix

Appendix B: Warranty

The Warranty

The Companies warrants the Montigo Gas Appliance to be free from defects in materials and workmanship at the time of manufacture. On the Montigo fireplace, there is a ten-year warranty on the firebox and its components, a five-year warranty on the main burner and pilot burner, and a one-year warranty on the gas control valve, fibre logs and Power Vent Module. The Glass, plated / painted finishes, and refractory lining are exempt from the warranty.

Remedy And Exclusions

The coverage of this Warranty is limited to all components of the Gas Appliance manufactured by The Companies.

This Warranty only covers Montigo Gas Appliances installed in the United States or Canada.

If the components of the Gas Appliance covered by this Warranty are found to be defective within the time frame stated (see The Companies right of investigation outlined below). The Companies will, at its option, replace or repair defective components of the Gas Appliance manufactured by The Companies at no charge, and will also pay for reasonable labour costs incurred in replacing or repairing components. If repair or replacement is not commercially practical, The Companies will, at its option, refund the purchase price of the Montigo Gas Appliance.

This Warranty covers only parts and labour as provided above. In no case shall The Companies be responsible for materials, components, or construction which are not manufactured or supplied by The Companies, or for the labour necessary to install, repair or remove such materials, components or construction. All replacement or repair components will be shipped F.O.B. the nearest The Companies factory.

Qualifications To The Warranty

The Gas Appliance Warranty outlined above is further subject to the following qualifications:

- (1) The Gas Appliance must be installed in accordance with The Companies installation instructions and local building codes. The Warranty on this Montigo Gas Appliance covers only the component parts manufactured by The Companies. The use of components manufactured by others with this Montigo Gas Appliance could create serious safety hazards, may result in the denial of certification by recognized national safety agencies, and could be in violation of local building codes. This warranty does not cover any damages occurring from the use of any components not manufactured or supplied by The Companies
- (2) The Montigo Gas Appliance must be subjected to normal use. The Gas Appliances are designed to burn gas only. Burning conventional fireplace fuels such as wood, coal or any other solid fuel will cause damage to the Gas Appliance, will produce excessive temperatures and will result in a fire hazard.

Limitations On Liability

It is expressly agreed and understood that The Companies sole obligation, and purchaser's exclusive remedy under this Warranty, under any other warranty, expressed or implied, or in contract, tort or otherwise, shall be limited to replacement, repair, or refund, as specified above.

In no event shall The Companies be responsible for any incidental or consequential damages caused by defects in its products, whether such damage occurs or is discovered before or after replacement or repair, and whether or not such damage is caused by The Companies negligence. Some states do not allow the exclusion or limitation of incidental or consequential damages, so the above limitation or exclusion may not apply to you. The duration of any implied warranty with respect to this Montigo Gas Appliance is limited to the duration of the foregoing warranty. Some states do not allow limitation on how long an implied warranty lasts, so the above may not apply to you.

Investigation Of Claims Against Warranty

The Companies reserves the right to investigate any and all claims against this Warranty and to decide upon method of settlement.

The Companies Are Not Responsible For Work Done Without Written Consent

The Companies shall in no event be responsible for any warranty work done without first obtaining The Companies written consent.

Dealers Have No Authority To Alter This Warranty

The Companies employees and dealers have no authority to make any warranties nor to authorize any remedies in addition to or inconsistent with those stated above.

How To Register A Claim Against Warranty

In order for any claim under this Warranty to be valid, The Companies must be notified of the claimed defect in writing or by telephone, as soon as reasonably possible after the defect is discovered. Claims against this Warranty in writing should include the date of installation, and a description of the defect.

Other Rights

This Warranty gives you specific legal rights, and you may also have other rights which vary from state to state.

NOTE: *The Companies* as stated above refer to - Canadian Heating Products Inc. and/or Montigo Del Ray Corp.

Canadian Heating Products Inc. and/or Montigo DelRay Corp. reserves the right to make changes at any time, without notice, in design, materials, specifications, prices and also to discontinue colors, styles and products.

Appendix

Appendix C: State of Massachusetts

Amendment

(Gas Fireplace / Equipment sold in the State of Massachusetts)

5.08: Modifications to NFPA-54, Chapter 10

(1) Revise NFPA-54 section 10.5.4.2 by adding a second exception as follows:

Existing chimneys shall be permitted to have their use continued when a gas conversion burner is installed, and shall be equipped with a manually reset device that will automatically shut off the gas to the burner in the event of a sustained back-draft.

(2) Revise 10.8.3 by adding the following additional requirements:

(a) For all side wall horizontally vented gas fueled equipment installed in every dwelling, building or structure used in whole or in part for residential purposes, including those owned or operated by the Commonwealth and where the side wall exhaust vent termination is less than seven (7) feet above finished grade in the area of the venting, including but not limited to decks and porches, the following requirements shall be satisfied:

1. INSTALLATION OF CARBON MONOXIDE DETECTORS. At the time of installation of the side wall horizontal vented gas fueled equipment, the installing plumber or gas fitter shall observe that a hard wired carbon monoxide detector with an alarm and battery back-up is installed on the floor level where the gas equipment is to be installed. In addition, the installing plumber or gas fitter shall observe that a battery operated or hard wired carbon monoxide detector with an alarm is installed on each additional level of the dwelling, building or structure served by the side wall horizontal vented gas fueled equipment. It shall be the responsibility of the property owner to secure the services of qualified licensed professionals for the installation of hard wired carbon monoxide detectors

a. In the event that the side wall horizontally vented gas fueled equipment is installed in a crawl space or an attic, the hard wired carbon monoxide detector with alarm and battery back-up may be installed on the next adjacent floor level.

b. In the event that the requirements of this subdivision can not be met at the time of completion of installation, the owner shall have a period of thirty (30) days to comply with the above requirements; provided, however, that during said thirty (30) day period, a battery operated carbon monoxide detector with an alarm shall be installed.

2. APPROVED CARBON MONOXIDE DETECTORS. Each carbon monoxide detector as required in accordance with the above provisions shall comply with NFPA 720 and be ANSI/UL 2042 listed and IAS certified.

3. SIGNAGE. A metal or plastic identification plate shall be permanently mounted to the exterior of the building at a minimum height of eight (8) feet above grade directly in line with the exhaust vent terminal for the horizontally vented gas fueled heating appliance or equipment. The sign shall read, in print size no less than one-half (1/2) inch in size, "GAS VENT DIRECTLY BELOW. KEEP CLEAR OF ALL OBSTRUCTIONS".

4. INSPECTION. The state or local gas inspector of the side wall horizontally vented gas fueled equipment shall not approve the installation unless, upon inspection, the inspector observes carbon monoxide detectors and signage installed in accordance with the provisions of 248 CMR 5.08(2)(a)1 through 4.

(b) EXEMPTIONS: The following equipment is exempt from 248 CMR 5.08(2)(a)1 through 4:

1. The equipment listed in Chapter 10 entitled "Equipment Not Required To Be Vented" in the most current edition of NFPA 54 as adopted by the Board; and

2. Product Approved side wall horizontally vented gas fueled equipment installed in a room or structure separate from the dwelling, building or structure used in whole or in part for residential purposes.

(c) **MANUFACTURER REQUIREMENTS - GAS EQUIPMENT VENTING SYSTEM PROVIDED.** When the manufacturer of Product Approved side wall horizontally vented gas equipment provides a venting system design or venting system components with the equipment, the instructions provided by the manufacturer for installation of the equipment and the venting system shall include:

1. Detailed instructions for the installation of the venting system design or the venting system components; and

2. A complete parts list for the venting system design or venting system.

(d) **MANUFACTURER REQUIREMENTS - GAS EQUIPMENT VENTING SYSTEM NOT PROVIDED.** When the manufacturer of a Product Approved side wall horizontally vented gas fueled equipment does not provide the parts for venting the flue gases, but identifies "special venting systems", the following requirements shall be satisfied by the manufacturer:

1. The referenced "special venting system" instructions shall be included with the appliance or equipment installation instructions; and

2. The "special venting systems" shall be Product Approved by the Board, and the instructions for that system shall include a parts list and detailed installation instructions.

(e) A copy of all installation instructions for all Product Approved side wall horizontally vented gas fueled equipment, all venting instructions, all parts lists for venting instructions, and/or all venting design instructions shall remain with the appliance or equipment at the completion of the installation.

(3) After NFPA-54 section 10.10.4.2 add a new section 10.10.4.3 as follows:

When more than four gas appliances are to be vented through a common gas vent or common horizontal vent manifold, a plan of the proposed vent installation shall be submitted to the Inspector and the serving gas supplier for review and approval.

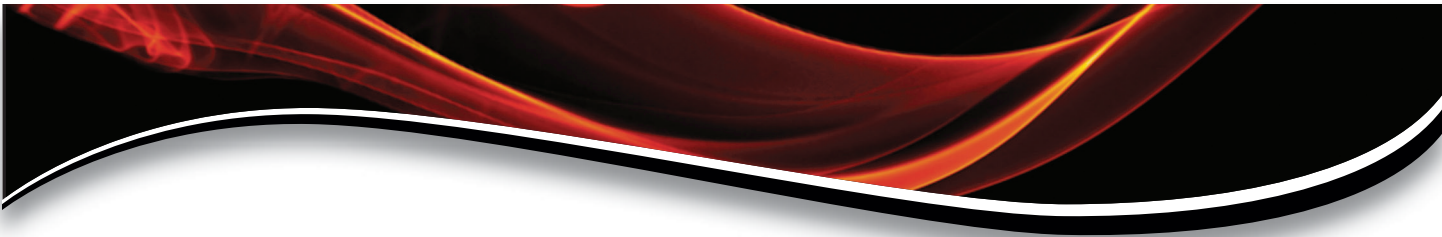

L42DF
Residential
Gas Fireplace

