

Mini-Rooter XP[®]

Operating Instructions

For 1-1/4" through 4" lines
(30mm—100mm)



Your Mini-Rooter XP is designed to give you years of trouble-free, profitable service. However, no machine is better than its operator.

Read, understand and follow all safety warnings and instructions provided with the product. Failure to follow the warnings and instructions may result in electric shock and/or serious injury. Save all warnings and instructions for future reference.

SAVE THESE INSTRUCTIONS!

General
PIPE CLEANERS



! WARNING

Read and understand operator's manual before using this machine. Failure to follow operating instructions could result in death or serious injury.

WARNING! Read and understand all instructions. Failure to follow all instructions listed below may result in electric shock, fire and/or serious personal injury. Replacement manuals are available upon request at no charge, or may be downloaded from our website, www.drainbrain.com. Instructional videos are available for download on our website, and may be ordered. If you have any questions or problems, please call General's customer service department at 412-771-6300.

SAVE THESE INSTRUCTIONS!

These instructions are intended to familiarize all personnel with the safe operation and maintenance procedures for the Mini-Router XP.

SAFETY SYMBOLS



This is the safety alert symbol. It is used to alert you to potential personal injury hazards. Obey all safety messages that follow this symbol to avoid possible injury or death.

! DANGER

DANGER indicates a hazard with a high level of risk which, if not avoided, will result in death or serious injury.

! WARNING

WARNING indicates a hazard with a medium level of risk which, if not avoided, could result in death or serious injury.

! CAUTION

CAUTION indicates a hazard with a low level of risk which, if not avoided, will result in minor or moderate injury.

! WARNING



Electric shock resulting in death can occur if you plug this machine into an improperly wired outlet. If the ground wire is electrified, you can be electrocuted by just touching the machine, even when the power switch is off. A ground fault circuit interrupter will not protect you in this situation. Use a UL approved tester to determine if the outlet is safe.



Do not operate power tools in explosive atmospheres, such as in the presence of flammable liquids, gases, or dust. Power tools create sparks which may ignite dust or fumes.



Only wear leather gloves. Never use any other type of glove, such as cloth, rubber, or coated gloves. Never grasp a rotating cable with a rag. These items could become wrapped around the cable and cause serious injury.



Always wear safety glasses and rubber soled, non-slip shoes. Use of this safety equipment may prevent serious injury.



Never operate machine with belt guard removed. Fingers can get caught between belt and pulley.

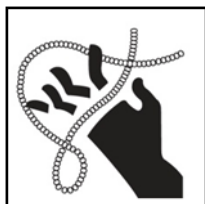

Do not overstress cables. Overstressing cables may cause twisting, kinking, or breaking of the cable and may result in serious injury.

GENERAL SAFETY RULES



WARNING

Read and understand all instructions. Failure to follow all instructions listed below may result in electric shock, fire, and/or serious injury.

SAVE THESE INSTRUCTIONS!

Work Area

1. **Keep work area clean and well lit.** Cluttered benches and dark areas invite accidents.
2. **Do not operate power tools in explosive atmospheres, such as in the presence of flammable liquids, gases, or dust.** Power tools create sparks which may ignite the dust or fumes.
3. **Keep bystanders, children, and visitors away while operating a power tool.** Distractions can cause you to lose control.

Electrical Safety

1. **Grounded tools must be plugged into an outlet, properly installed and grounded in accordance with all codes and ordinances. Never remove the grounding prong or modify the plug in any way. Do not use any adapter plugs. Check with a qualified electrician if you are in doubt as to whether the outlet is properly grounded.** If the tool should electrically malfunction or break down, grounding provides a low resistance path to carry electricity away from the user.
2. **Avoid body contact with grounded surfaces such as pipes, radiators, ranges and refrigerators.** There is an increased risk of electric shock if your body is grounded.
3. **Do not expose power tools to rain or wet conditions.** Water entering a power tool will increase the risk of electric shock.
4. **Do not abuse the cord.** Never use the cord to carry the tools or pull the plug from an outlet. Keep cord away from heat, oil, sharp edges or moving parts. Replace damaged cords immediately. Damaged cords increase the risk of electric shock.
5. **When operating a power tool outside use an outdoor extension cord marked "W-A" or "W".** These cords are rated for outdoor use and reduce the risk of electric shock.
6. **Test the Ground Fault Circuit Interrupter (GFCI) provided with the power cord to insure it is operating correctly before operating machine.** Machine must have a properly functioning ground fault circuit interrupter on the power cord. GFCI reduces the risk of electric shock.
7. **Extension cords are not recommended unless they are plugged into a Ground Fault Circuit Interrupter (GFCI) found in circuit boxes or outlet receptacles.** The GFCI on the machine power cord will not prevent electric shock from the extension cords.
8. **Only use proper three-wire extension cords in good condition which have three-prong grounding plugs and three-pole receptacles which accept the tool's plug.** Use of damaged, inferior, or other extension cords will not ground the tool. Increases the risk of electric shock and bodily injury or death.
9. **Keep all electric connections dry and off the ground.** Reduces the risk of electric shock.
10. **DO NOT touch plugs or tools with wet hands.** Reduces the risk of electric shock.

Personal Safety

1. **Stay alert, watch what you are doing and use common sense when operating a power tool. Do not use tool while tired or under the influence of drugs, alcohol, or medication.** A moment of inattention while operating power tools may result in serious personal injury.
2. **Dress properly. Do not wear loose clothing or jewelry. Contain long hair. Keep your hair, clothing, and gloves away from moving parts.** Loose clothes, jewelry, or long hair can be caught in moving parts.
3. **Avoid accidental starting. Be sure switch is off before plugging in.** Carrying tools with your finger on the switch or plugging in tools that have the switch on invites accidents.
4. **Remove adjusting keys or switches before turning the tool on.** A wrench or key that is left attached to a rotating part of the tool may result in personal injury.
5. **Do not overreach. Keep proper footing and balance at all times.** Proper footing and balance enables better control of the tool in unexpected situations.
6. **Use safety equipment. Always wear eye protection.** Dust mask, non-skid safety shoes, hard hat, or hearing protection must be used for appropriate conditions.

Tool Use and Care

1. **Use clamps or other practical way to secure and support the workpiece to a stable platform.** Holding the work by hand or against your body is unstable and may lead to loss of control.
2. **Do not force tool. Use the correct tool for your application.** The correct tool will do the job better and safer at the rate for which it is designed.
3. **Do not use tool if switch does not turn it on or off.** Any tool that cannot be controlled with the switch is dangerous and must be repaired.
4. **Disconnect the plug from the power source before making any adjustments, changing accessories, or storing the tool.** Such preventative safety measures reduce the risk of starting the tool accidentally.
5. **Store idle tools out of reach of children and other untrained persons.** Tools are dangerous in the hands of untrained users.
6. **Maintain tools with care. Keep cutting tools sharp and clean.** Properly maintained tools, with sharp cutting edges are less likely to bind and are easier to control.
7. **Check for misalignment or binding of moving parts, breakage of parts, and any other condition that may affect the tool's operation. If damaged, have the tool serviced before using.** Many accidents are caused by poorly maintained tools.
8. **Only use accessories that are recommended by the manufacturer for your model.** Accessories that may be suitable for one tool may become hazardous when used on another tool.

Service

1. **Tool service must be performed only by qualified repair personnel.** Service or maintenance performed by unqualified repair personnel could result in a risk of injury.
2. **When servicing a tool, use only identical replacement parts. Follow instructions in the Maintenance section of this manual.** Use of unauthorized parts or failure to follow Maintenance Instructions may create a risk of electric shock or injury.

SPECIFIC SAFETY RULES



This is the safety alert symbol. It is used to alert you to potential personal injury hazards. Obey all safety messages that follow this symbol to avoid possible injury or death.



Electric shock resulting in death can occur if you plug this machine into an improperly wired outlet. If the ground wire is electrified, you can be electrocuted by just touching the machine, even when the power switch is off. A ground fault circuit interrupter will not protect you in this situation. Use a UL approved tester to determine if the outlet is safe.



Do not overstress cables. Overstressing cables may cause twisting, kinking, or breaking of the cable and may result in serious injury.

1. **Only wear leather gloves.** Never use any other type of glove, such as cloth, rubber, or coated gloves. Never grasp a rotating cable with a rag. These items could become wrapped around the cable and cause serious injury.
2. **Never operate machine with belt guard removed.** Fingers can get caught between belt and pulley.
3. **Do not overstress cables.** Keep leather-gloved hand on the cable for control when machine is running. Overstressing cables because of an obstruction may cause twisting, kinking, or breaking of the cable and may result in serious injury.
4. **Place the machine at a distance not greater than two feet from the opening.** Greater distances can result in cable twisting or kinking.
5. **Machine is designed for ONE-PERSON operation.** Operator must control foot switch and cable.
6. **Do not operate machine in reverse (REV).** Operating machine in reverse can result in cable damage and is used only to back cutting tool out of an obstruction.
7. **Keep hands away from rotating drum.** Do not reach into drum unless machine is unplugged. Hand may be caught in the moving parts resulting in serious injury.
8. **Be careful when cleaning drains where cleaning chemicals have been used.** Avoid direct contact with skin and eyes. Drain cleaning chemicals can cause serious burns as well as damage the cable.
9. **Do not operate machine if operator or machine is standing in water.** Will increase risk of electrical shock.
10. **Wear safety glasses and rubber soled, non-slip shoes.** Use of this safety equipment may prevent serious injury.
11. **Before starting each job, check that the cable in the drum is not broken or kinked, by pulling the cable out and checking for wear or breakage.** Always replace worn out (kinked or broken) cables with genuine GENERAL replacement cables.
12. **Only use this tool in the application for which it was designed. Follow the instructions on the proper use of the machine.** Other uses or modifying the drain cleaner for other applications may increase risk of injury.

Ground Fault Circuit Interrupter (GFCI)

Your machine is equipped with a ground fault circuit interrupter, which protects you against shock if a short circuit should occur. Check that receptacle is properly grounded. Test the GFCI before each use.

1. Plug into 120-volt receptacle.
2. Push test button. Indicator light will go out and power to machine should cut off.
3. If light does not go out when test button is pushed, **DO NOT USE THE MACHINE** until proper repairs can be made.
4. To restore power after test, push reset button. With the reset button depressed, if the machine doesn't start, stops while running, or if the operator experiences a mild shock, **DO NOT USE THE MACHINE!** Tag the machine out of service and take it to a motor repair center or return it to the factory for repairs.



THE SECTION OF CORD BETWEEN THE WALL PLUG AND THE GFCI IS NOT IN THE PROTECTED CIRCUIT.

FEATURES - Closed Drum Mini-Router XP

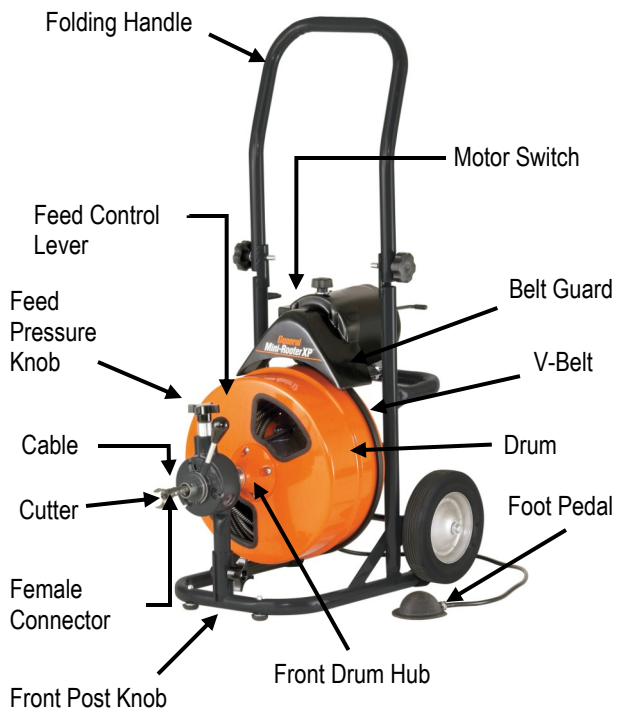

Shown Right: Power Cable Feed with Guide Tube

NOTE: Do not operate machine if warning labels on the switch box and power cord are missing or illegible.

FEATURES - Open Drum Mini-Router XP

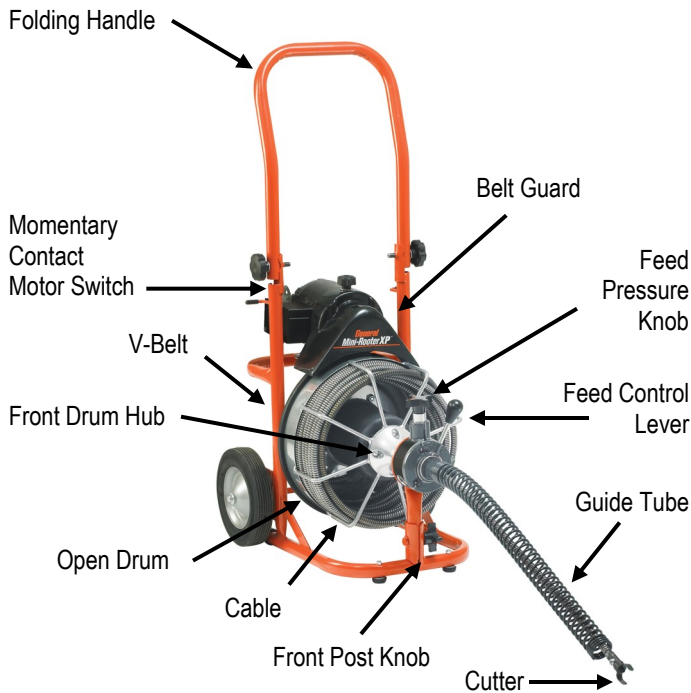

NOTE: Do not operate machine if warning labels on the switch box and power cord are missing or illegible.

Cable Application Chart (Table 1)

Cable Size	Pipe Size	Typical Applications	Max. Capacity
1/2"	3" to 4"	Roof Stacks and Small Floor Drains (No roots)	75 ft.
3/8"	2" to 3"	Roof Stacks, Laundry Lines and Small Drains	75 ft.
*5/16"	1-1/2" to 2"	Sinks, Basins and Small Drains	50 ft.
*1/4"	1-1/4" to 2"	Small Lines, Tubs and Shower Drains	50 ft.

*The 1/4" and 5/16" diameter cables are for use with the J-Drum.

Cutter Application Chart (Table 2)

Cutter	Cat. #	Typical Applications
Cutters for 3/8" and 1/2" Cables		
Arrow Head	AH	Starting tool, ideal for cutting and scraping.
Boring Gimlet	BG	Starting tool, to remove loose objects.
1-1/2" U-Cutter	1-1/2UC	Finishing tool, works well in grease stoppages.
2" Side Cutter Blade	2SCB	Finishing tool, for scraping inside edges of pipe.

Note: There are no fixed rules for what cutter to use. If one tool doesn't take care of a stoppage, simply try another.

INSTALLING GUIDE TUBE HOLDER

1. The Guide Tube Holder on the Mini-Router XP should already be installed when you receive the machine. If not, follow the illustration below for assembly.

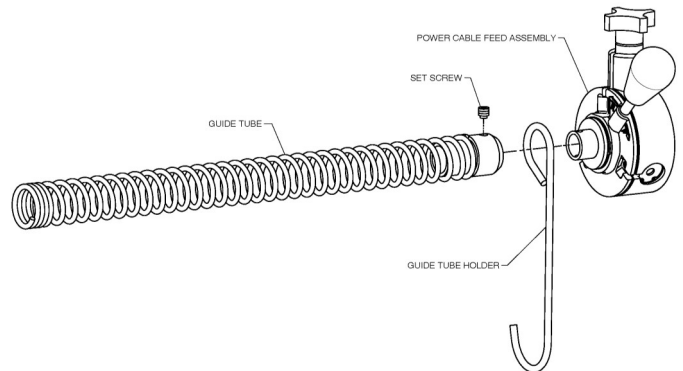

2. To secure the end of the Guide Tube, hold the Guide Tube Holder to one side of the frame.
3. Bend the Guide Tube back into the Holder so that it catches a coil near the end of the Guide Tube. (See photo below.)



THE CABLE AND SPRING ARE UNDER TENSION WHEN ATTACHED TO THE HOLDER. USE CAUTION WHEN RELEASING THE GUIDE TUBE FROM THE HOLDER.

OPERATING INSTRUCTIONS

MAKE SURE THE MOTOR SWITCH IS IN THE 'OFF' POSITION!

Set-Up

1. Place machine within approximately two feet (.6m) of drain opening. Be sure the Mini-Router XP Guide Tube (XP-GT) is in place. If you can't place the machine this close to the drain opening, run the cable through the optional Guide Tube Extension (GTE) or a metal guide tube to prevent cable whipping. On manual feed machines, always keep a gloved hand on the cable.
2. Position the foot pedal for easy accessibility. The machine is designed for one-person operation. Be sure you can quickly remove your foot from the pedal in an emergency.
3. Be sure the motor switch is in the **off** position.
4. Select the proper cutting tool (See Cutter Application Chart—Table 2). A good tool to start with is the Arrow Head or Boring Gimlet. After the line is opened, follow with larger blades, which scrape the inside edges of the pipe, assuring a real cleaning job.
5. Insert the cutter into the female connector at the end of the 3/8"



4. Move the motor switch to the **forward** position. Then with a gloved hand on the guide tube, depress the air foot pedal to start machine.
5. Feed the cable into the line and against the obstruction with a firm, even pressure. Adjust the feeding rate to the resistance met. Do not force the cable – let the cutter do the work. The job won't get done any faster and you could damage the cable.

DO NOT USE TOO MUCH FORCE – LET THE CUTTER DO THE WORK.

6. Don't leave too much slack in the cable since this will cause whipping. If the cable starts to bend or build up too much twist, release pressure on the foot pedal and rotate the drum in the opposite direction to relieve the twist on the cable. Push any excess cable back into the drum and then continue.

DO NOT ALLOW TOO MUCH SLACK IN THE CABLE BETWEEN MACHINE AND DRAIN OPENING SINCE THIS CAN CAUSE CABLE WHIPPING.

7. If you're having trouble getting around tight bends, try putting the machine in reverse while applying steady pressure. (If using Power Cable Feed, putting motor in reverse will cause the feed control lever to operate opposite of normal.)

Note: If your machine is equipped with a momentary contact reverse switch, you must hold the switch in position when operating the machine in reverse.

Operation

1. Begin by pulling the cable from the drum and sliding it into the drain as far as it will go.
2. Tighten the knob at the top of the Power Cable Feed so that the feed roller presses against the cable. Be sure not to over tighten since this could cause excess cable wear. Note: The Power Cable Feed is designed for use with 3/8" and 1/2" cables only.
3. The feed lever controls the feeding rate and direction of the cable. Move the lever down to feed the cable out of the drum. The further the lever is moved downward, the faster the cable will feed out. Move the lever up to retract the cable into the drum. When the lever is in the middle (neutral) position, the cable will spin in place.

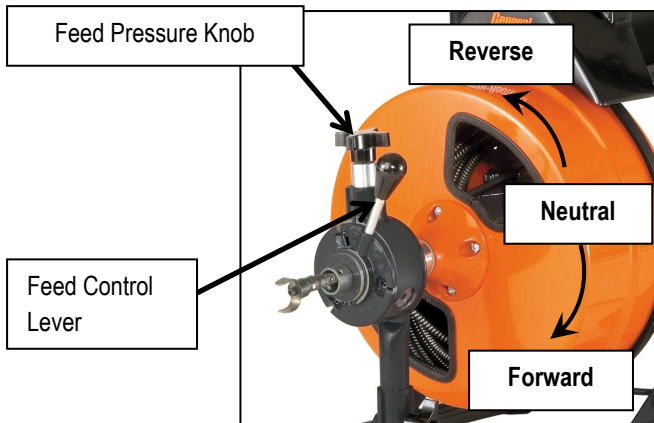

MOTOR SWITCH

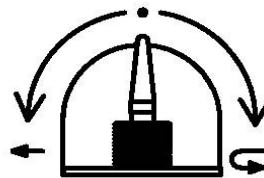

FORWARD - OFF - REVERSE

MOMENTARY CONTACT SWITCH

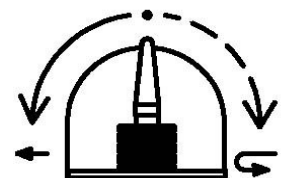

FORWARD - OFF - HOLD to REVERSE

Don't run motor in reverse for more than a few seconds at a time as this could cause tangling in the drum or kinking.

8. If you still can't get around the bend, you're probably using too large a cable. Switch to a 3/8" diameter cable, or even a smaller one if necessary. (See Cable Application Chart—Table 1)
9. When the cable reaches the stoppage, put feed in neutral. Then allow the cable to progress forward slowly, chewing into the stoppage as it goes. This slow forward movement will reduce stress on the cable while doing a more thorough cleaning job. A back and forth action often works best.

Hint: It's often helpful to have a small stream of water running in the line to wash the cuttings away while the machine is in operation and after.

10. Be careful not to let the cutter get caught in the stoppage as you work through it. This can cause kinking and breaking of the cable. When you feel the cable starting to twist in your hands, stop the machine and pull back on the cable. This will free the cutter from the obstruction. Then allow the cable to move forward slowly into the stoppage. Remember, no cutting takes place when the blades stop turning.
11. After the line has been opened, retract the cable by moving the feed lever up. Make sure the motor switch is in the **forward** position. This is important to prevent the cable from tangling in the drum or in the line.

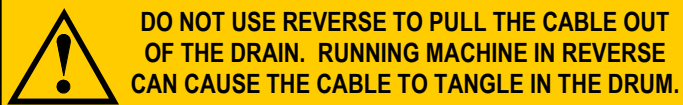

12. When the cutter is near the drain opening, take your foot off the pedal to stop drum rotation. Never retract the cutter from drain while cable is rotating. The cable could whip and cause serious injury.

SPECIAL OPERATIONS IF CABLE GETS CAUGHT IN LINE



The motor can be reversed for a few seconds at a time to free cable if it gets caught in the line. Use the following procedure:

1. Move motor switch to reverse position. (Open drum has momentary contact switch which must be held to operate in reverse.)
2. Wearing leather gloves, pull on cable while the drum is turning in reverse.
3. When the cable is freed, slide excess cable back into drum.
4. Move the motor switch to the forward position again, and continue at Step 3 of the Operating Instructions.

IF CABLE TANGLES IN DRUM

This is almost always caused by using too much pressure when feeding the cable, or by feeding the cable while running the machine in reverse. To untangle, rotate drum in opposite direction. This will usually get the cable to lie in the drum properly.

If cable has become badly tangled, which shouldn't happen when machine is used properly, it can be straightened out by removing the distributor tube from the drum. To do this:



1. Loosen the four bolts that hold the front drum hub on the front of the drum.
2. Pull the front drum hub and distributor tube forward, then pull the tangled portion of the cable out of the drum.
3. After the cable has been straightened out, slide the distributor tube and front drum hub back along the cable until it can be repositioned and bolted to the front of the drum.
4. Then, push the excess cable back into the drum.

HOW TO REMOVE DRUM FROM MACHINE



DISCONNECT MACHINE FROM POWER SOURCE BEFORE INSTALLING CABLES OR DRUMS!

1. Loosen the front post knob and swing Power Cable Feed out of the way.
2. Push down on the spring-loaded motor and slide the V-Belt off the back of the drum.
3. Reach behind the drum and locate the drum-retaining latch. Pull the latch to release the drum shaft, then pull the drum forward off of the machine.
4. To install the drum, simply slide drum onto machine. The latch will lock automatically.
5. Remove the belt guard by loosening retaining knob on top. Position the V-Belt around the drum, then press down on the motor and slip V-belt onto the pulley. Be sure to reattach the belt guard.
6. Reposition the Power Cable Feed and tighten knob at base of front post.



HOW TO INSTALL 3/8" AND 1/2" CABLES IN DRUM



DISCONNECT MACHINE FROM POWER SOURCE BEFORE INSTALLING CABLES OR DRUMS!

To install cable in the drum, simply connect the male end of the cable to the drum connecting cable, which is already attached to the drum. Then remove the drum V-Belt and turn the drum clockwise, while pushing the cable into the drum.

Note: The cable should lay in the drum in a clockwise direction.



HOW TO USE J-DRUM

(Optional—Cat. #MR-250)

The J-Drum holds 50 feet of 1/4" or 5/16" cable to be used when you need to clear smaller, 1-1/4" to 2" lines. These cables have a basin plug head that can be spun through most strainer crossbars. (See Cable Application Chart—Table 1.)



DISCONNECT MACHINE FROM POWER SOURCE BEFORE INSTALLING CABLES OR DRUMS!

1. To install cable, open chuck jaws fully so that cable will pass through easily.



- Slide the back end of the cable (opposite to the end with basin head) through spout and into the drum. The cable will be easier to install if you bend the last inch of cable at a 45-degree angle.
- When working through difficult stoppages or tight bends, tighten the chuck to provide more torque and to prevent the cable from tangling in the drum.
- Clean and lubricate chuck regularly to prevent corrosion.

MAINTENANCE



DISCONNECT MACHINE FROM POWER SOURCE BEFORE PERFORMING MAINTENANCE!

To keep your machine operating smoothly, it is essential that all bearings and distributor tube bushings be lubricated. Oiling moving parts is particularly important where machine comes in contact with sand, grit and other abrasive material.

CABLE MAINTENANCE

To get maximum service from your cables, be sure that they are clean and well oiled. This not only provides running lubrication but greatly extends the life of the cables as well. Some users periodically pour oil directly into the drum. Then, as the drum turns, the cables get complete lubrication. Our SNAKE OIL is ideally suited for this purpose, since it not only lubricates the cables, it deodorizes them as well.



FEED MAINTENANCE

Keep feed free of excessive soil and grit. It is recommended that the feed be flushed with fresh water followed by a light oiling of the moving parts. No disassembly is normally required. Failure to feed can usually be traced to the following possibilities:

DIRT ACCUMULATION

Over time, dirt can harden enough to stop roller rotation. Flushing with water followed by liberal oiling can usually restore function. If disassembly is required, proceed as follows:

- Remove the feed tension knob, springs and spring plunger. Note the positioning of these parts to ease re-assembly. The top roller can now be removed.
- Remove the snap rings and thrust washers from the bottom housing cylinders. The bottom rollers can now be removed.
- Re-assembly is done in reverse order.

DAMAGED ROLLER

Excessive use may wear a roller to the point of failure. It is recommended that all three rollers be replaced at the same time (Cat # PO-MR-703). The replacement roller is an assembly consisting of one Feed Roller, two Feed Roller Bearings, and two Bearing Spacers.

Note: The Bearing Spacers must be installed between the Carrier and each Feed Roller Bearing (as illustrated below) in order to ensure proper operation and to obtain maximum Feed Roller life.

To Replace the Feed Roller Assembly:

- Remove the Feed Roller Assembly by unscrewing and removing the Feed Roller Axle.
- For convenience, the components are assembled and wired together at the factory. Before attempting to install the assembly, hold the assembly together and remove the wire.
- While still holding the Feed Roller Assembly together, insert it into the slot opening of the Carrier.
- In order to help align the Spacers and Bearings, insert a pencil point or similar object through the **un-threaded** end of the Axle hole in the Carrier. After removing the pencil point, continue to maintain the alignment of the components.
- The Feed Roller Axle should then be inserted through the same un-threaded Axle hole and should continue to be guided through the Spacers and Bearings to the threaded Axle hole on the other side of the Carrier.
- Securely tighten the Axle to the Carrier with a 3/16" allen wrench.

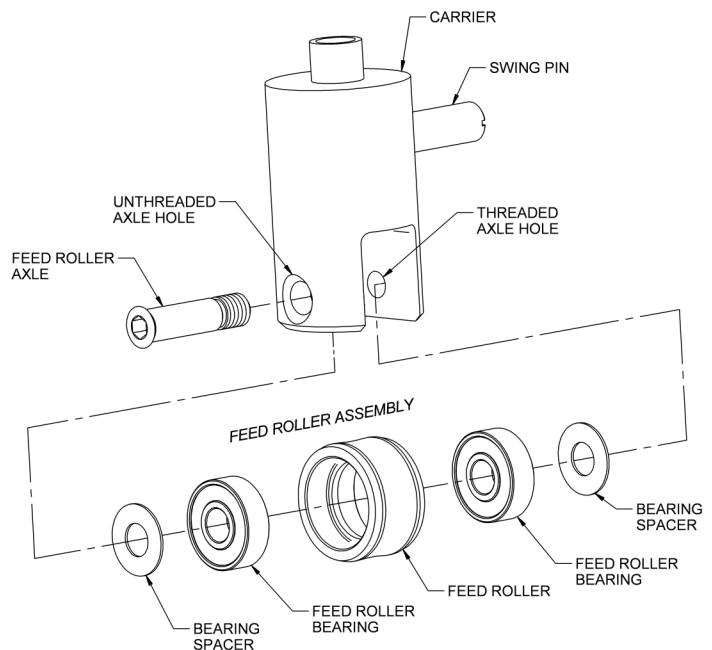

TANGLED CABLE

If a cable loops over itself in the drum, it will not feed properly. Remove and reload the cable to restore function. If the cable kinks, it is evidence of abuse and results from the use of too much pressure or use of the wrong size cable for the line. Do not force the cable — let the cutter do the work.

TROUBLE SHOOTING GUIDE (Table 3)

Problem	Probable Cause	Solution
Cable kinks or breaks.	Operator forcing the cable.	Do not force the cable. Let the cutter do the work.
	Too much slack between machine and drain.	Allow no more than two feet between machine and drain.
	Cable used in wrong size drain line.	A cable that is too large or too small in diameter for a line is more likely to kink. (Consult Table 1—Cable Applications.)
	Cable exposed to acid.	Clean and oil cables regularly.
Cable tangles in drum/cage.	Operator forcing the cable.	Do not force the cable. Let the cutter do the work.
	Machine running in reverse.	Do not run the machine in reverse to retract the cable from the drain.
Drum stops while foot pedal depressed.	Hole in pedal or hose.	Replace as required.
	Hole in diaphragm switch.	If no hole found in pedal or hose, replace diaphragm switch.
Drum turns in one direction but not other.	Faulty reverse switch or momentary contact switch.	Replace reverse switch. Note: Momentary contact switch must be held in position when using reverse.
Ground fault circuit interrupter trips and will not reset.	Damaged power cord or extension cord.	Replace cords.
	Short circuit in motor.	Take motor to authorized repair center.
	Faulty ground fault circuit interrupter.	Replace ground fault circuit interrupter.
Motor turns but drum does not.	Safety Slip Clutch (optional) engaged.	Do not force cable.
Failure to feed.	Cable tangled in drum.	Do not run machine in reverse. Use proper cable size. (Consult Cable Application Chart—Table 1).
	Feed misadjusted.	If feed tension knob is too loose the cable will slip. If it is too tight the feed rollers will wear prematurely.
	Feed roller frozen.	Clean and lubricate feed rollers regularly. Replace worn rollers.
	Worn cable.	When cable coils wear flat, cable should be replaced.

General Wire Spring Co.
1101 Thompson Avenue
McKees Rocks, PA 15136
412-771-6300 www.drainbrain.com