

## MINI-ROOTER XP PARTS LIST

ITEM NO.	CATALOG NO.	DESCRIPTION	ITEM NO.	CATALOG NO.	DESCRIPTION
169005	XP-100-2	Complete Frame Assembly	169330	XP-303	V-Belt Pulley
169007	XP-100-R	Complete Frame Assembly (Orange)	136180	XP-303-1	Safety Slip Clutch
169017	XP-101-2	Frame Only	169340	XP-304	Motor Support w/Nuts, Bolts & Washers
169018	XP-101-R	Frame Only (Orange)	169345	XP-304-A	Nuts, Bolts & Washers (4)
169020	XP-102-1	Rubber Leg Tip (2)	169350	XP-304-B	Guide Screws (2)
169022	XP-103	Rubber Foot, Washer & Nut (2)	169355	XP-305	Motor Support Spring
169025	XP-104	Drum Shaft Retaining Pin	136200	XP-306	V-Belt (45")
169030	XP-104-A	Retaining Pin Spring	169400	XP-307	Belt Guard
169035	XP-104-B	Retaining Pin Collar w/Set Screw	169405	XP-308	Air Switch & Reverse Switch Assembly
169037	XP-105	Shaft Spacer w/Set Screw	169407	XP-308-R	Air Switch & Reverse Switch Assembly
169045	XP-107-1	Folding Handle	169410	XP-308-A	Box Only w/Cover & Screws
169046	XP-107-R	Folding Handle (Orange)	136070	XP-308-B	Foot Pedal & Hose
169047	XP-108	Rubber Tip (2)	169420	XP-308-C	Cable Tie
169050	XP-110	8" Wheel (2)	136060	XP-308-D	Foot Pedal Only
169055	XP-111	Wheel Retaining Cap (2)	136080	XP-308-E	Power Switch Diaphragm
169060	XP-112	Wheel Spacer (2)	136050	XP-308-F	Air Hose Only
169023	XP-115	Front Post	169440	XP-308-G	Reverse Switch (3-Way)
169024	XP-115-R	Front Post	136210	XP-308-G-R	Momentary Contact Reverse Switch (Red)
169065	XP-116	Post Locking Knob	169450	XP-308-K	Switch Guard
169070	XP-117	Post Support Bracket	156395	XP-308-N	Strain Relief Nut
169080	XP-118	Guide Tube Holder	164550	XP-309	Motor Guard w/Nylon Strip
169085	XP-119	Bolt w/ Lock Washer	164555	XP-309-A	Nylon Strip
169120	XP-200	Complete Drum Assembly w/Inner Cage (Closed)	136010	GFI-10	Ground Fault Circuit Interrupter w/10' Cord
169125	XP-200-O	Complete Drum Assembly w/Inner Cage (Open)	169465	PO-XP	Complete XP Power Cable Feed
169130	XP-201	Drum Shell	169466	PO-XP-R	Complete XP Power Cable Feed for Rental
169133	XP-201-R	Open Drum Shell	168904	PO-MR-101	Power Feed Body
169135	XP-201-A	Edging	168905	PO-MR-101-A	Spout
169143	XP-202-1	Drum Shaft	168906	PO-MR-102	Lifting Spring
169145	XP-202-A	Front Shaft Retaining Ring	168909	PO-MR-200	Feed Roller Assembly
169150	XP-202-B	Flat Washer	168910	PO-MR-200-R	Feed Roller Assembly for Rental
169155	XP-202-C	Felt Washer	168912	PO-MR-210	Carrier Only
169160	XP-202-D	Rear Shaft Retaining Ring	68913	PO-MR-210-R	Carrier Only for Rental
169165	XP-203	Rear Hub Assembly w/Bushing	168915	PO-MR-220	Swing Pin
169175	XP-203-B	Screws & Flanged Locknuts (5)	168916	PO-MR-220-R	Swing Pin for Rental
169180	XP-204	Distributor Tube and Inner Drum Assembly	168918	PO-MR-225	Feed Roller Shaft
168997	XP-204-1	Flexitube Distributor Tube Assembly	136160	PO-MR-250	Feed Roller
169250	XP-205	Fiber Washer (3)	168924	PO-MR-301	Feed Pressure Knob Assembly
169260	XP-206	Front Hub w/Bushing (Orange)	168929	PO-MR-315	Outer Pressure Spring
169263	XP-206-R	Front Hub w/Bushing (Silver)	168936	PO-MR-330-1	Washer
169270	XP-207	Round Head Cap Screws (4)	168938	PO-MR-510	Bottom Roller Assembly Retaining Snap Ring
169280	XP-208	Distributor Tube Front Collar w/Set Screw	168941	PO-MR-530	Thrust Washer
169240	XP-209-1	Inner Drum Cage	168944	PO-MR-601	Feed control Disc w/Lever & Knob
169290	XP-210	Drum Connecting Cable	168945	PO-MR-601-A	Lever & Knob
169300	XP-210-A	Connecting Cable Bolt, Nut & Washer	168949	PO-MR-602	Control Disc Retaining Snap Ring
169360	XP-216	Inner Drum Retaining Bolt	136150	PO-MR-703	Set of Feed Rollers (3)
169365	XP-217	Drum Retaining Washer	168435	MR-GT	Guide Tube
169370	XP-218	Felt Washer	132355	XP-DVD	Instructional DVD
169380	XP-219	High Collar Lock Washer	132210	XP-DECALS	Set of Safety Decals
169305	XP-300	Motor 1/3 hp w/GFCI, Air Foot Switch, & Rev. Switch	170990	AFH	Condensed Operating Instructions (Instructions w/Chain & Fittings, Connector, & Screw)
169307	XP-300-R	Motor 1/3 hp w/GFCI, Air Foot Switch, & Rev. Switch	169480	XPOI	Complete Operating Instructions
169310	XP-302	Belt Guard Retaining Knob			
167060	XP-302-A	Washer			

# MINI-ROOTER XP SCHEMATIC DIAGRAM

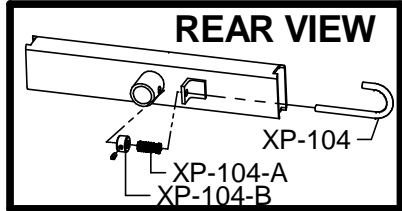
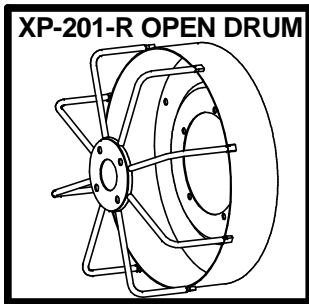
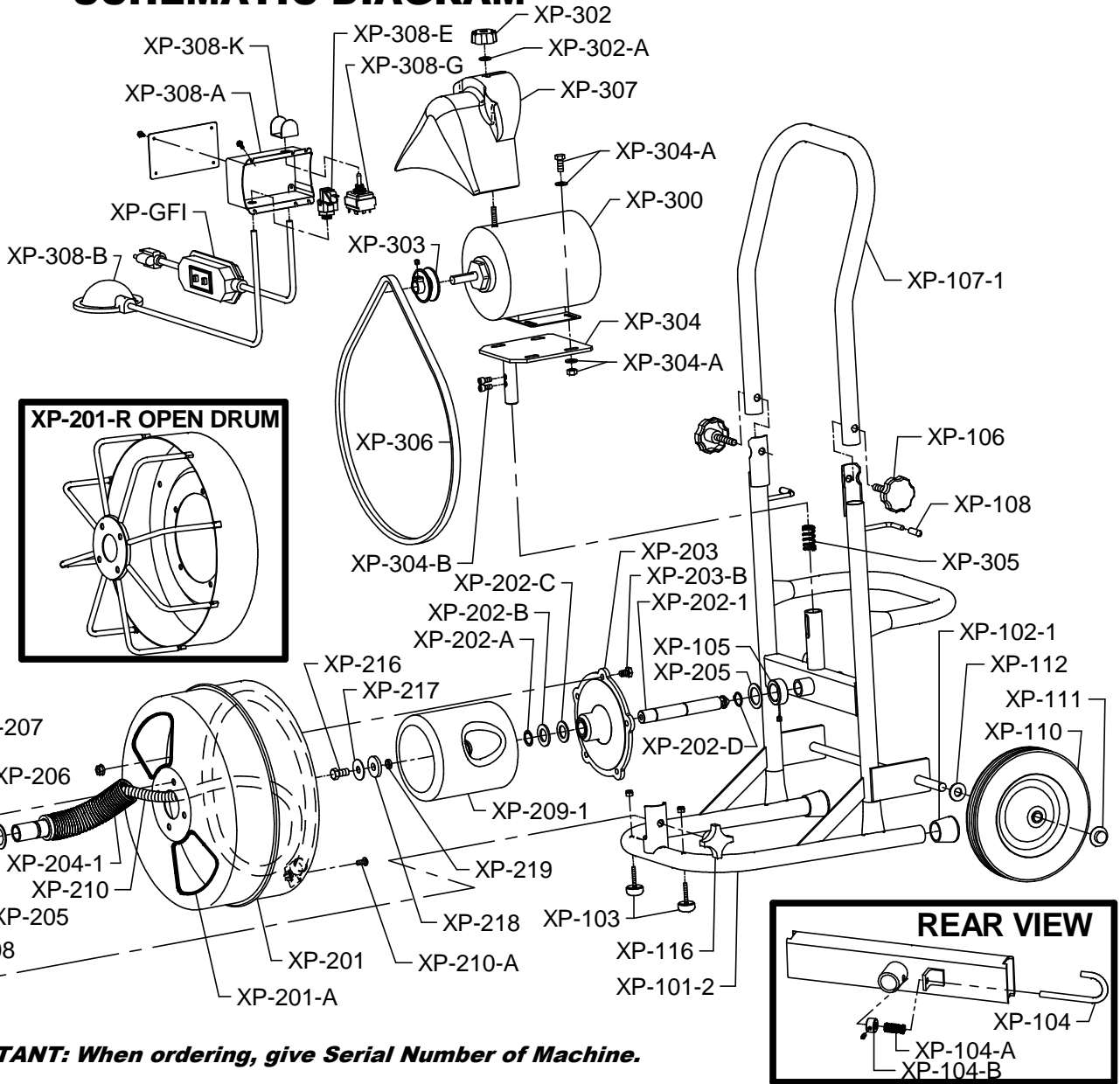
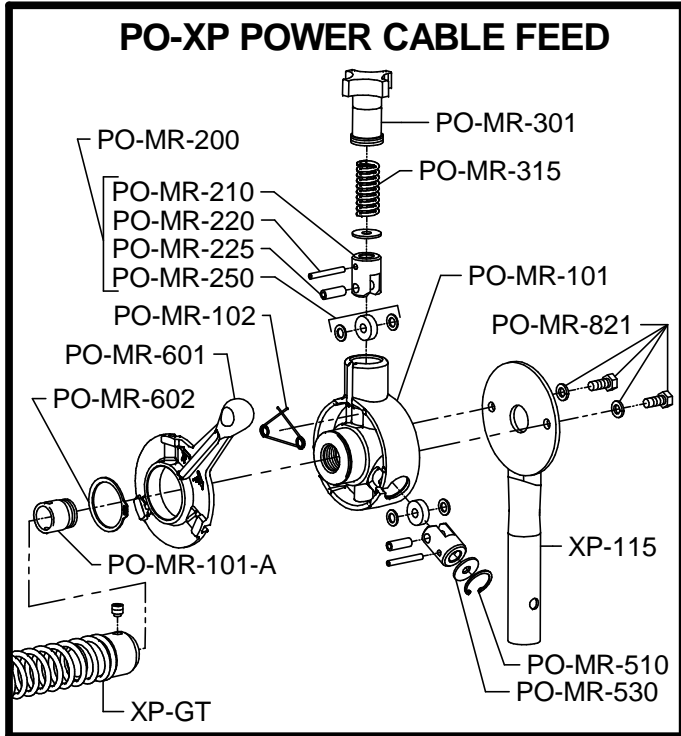

**IMPORTANT: When ordering, give Serial Number of Machine.**