



# INSTALLATION, OPERATION & MAINTENANCE INSTRUCTIONS

1455 Kleppe Lane ♦ Sparks, NV 89431-6467 ♦ (775) 359-4712 ♦ Fax (775) 359-7424  
E-mail: [haws@hawsco.com](mailto:haws@hawsco.com) ♦ website: [www.hawsco.com](http://www.hawsco.com)

No. 2076717(16)

## Model 1119.14 Drinking Fountain

**NOTE TO INSTALLER: Please leave this information with the Maintenance Department.**

### LIMITED WARRANTY

HAWS® warrants that all of its products are guaranteed against defective material or poor workmanship for a period of **one year from date of shipment**. HAWS liability under this warranty shall be discharged by furnishing without charge F.O.B. HAWS Factory any goods, or part thereof, which shall appear to the Company upon inspection to be of defective material or not of first class workmanship, provided that claim is made in writing to company within a reasonable period after receipt of the product. Where claims for defects are made, the defective part or parts shall be delivered to the Company, prepaid, for inspection. HAWS will not be liable for the cost of repairs, alterations or replacements, or for any expense connected therewith made by the owner or his agents, except upon written authority from HAWS, Sparks, Nevada. HAWS will not be liable for any damages caused by defective materials or poor workmanship, except for replacements, as provided above. Buyer agrees that Haws has made no other warranties either expressed or implied in addition to those above stated, except that of title with respect to any of the products or equipment sold hereunder and that HAWS shall not be liable for general, special, or consequential damages claimed to arise under the contract of sale. The drinking fountain manufactured by HAWS is warranted to function if installation and maintenance instructions provided are adhered to. The units also must be used for the purpose for which they were intended.

**NO OTHER WARRANTIES EXPRESSED OR IMPLIED ARE AUTHORIZED, PROVIDED OR GIVEN BY HAWS.**

**SHOULD YOU EXPERIENCE DIFFICULTY WITH THE INSTALLATION OF THIS MODEL PLEASE CALL:**

**TECHNICAL SUPPORT: 1-800-766-5612**

**FOR CUSTOMER SERVICE: 1-888-640-4297**

**RECOMMENDED TOOLS:** Hack saw, pipe joint sealant, screwdriver, level, 12" adjustable wrench, 10" pipe wrench, 5/64" hex key wrench, 9/16", 1/2", 7/16" socket wrench or open end wrench.

**LOCATION OF UNIT:** The Model 1119.14 Drinking Fountain is a wheelchair accessible drinking water facility. The height dimensions that are shown meet current ADA requirements. When installing this unit, local, state or federal codes should be adhered to. If height other than shown is required, then dimensions must be adjusted accordingly.

**SUPPLY LINE:** The minimum recommended line size is 1/2" IPS with 30-90 psi (2-6 ATM) pressure. Where sediment or mineral content is a problem, an inlet filter is recommended.

**PLUMBING CONNECTIONS:** Inlet is 3/8" push-in type fitting. Waste outlet is female 1-1/4" IPS.

**MAINTENANCE:** Periodically clean the strainer. Refer to 5874SS Valve Manual for more information.

## TROUBLESHOOTING

PROBLEM	REPAIR CHECKLIST
1. Insufficient bubbler flow.	<ul style="list-style-type: none"><li>1a. Check that inlet screwdriver stop valve is wide open. Turn counter-clockwise.</li><li>1b. Verify minimum 30 psi flowing supply pressure.</li><li>1c. Clean strainer. See 5874SS Valve Manual</li><li>1d. Adjust valve to increase flow. Use front adjust screw or see 5874SS Valve Manual.</li></ul>

**GENERAL NOTES:**

For all plastic push-in type fitting connections; push tubing into fitting until it bottoms out to ensure a watertight connection. To remove, depress the collet and pull tubing out. Only connect NSF-61 copper or plastic tubing to these push-in type fittings.

For more information about Haws products, see our website: [www.hawSCO.com](http://www.hawSCO.com)

ITEM	DESCRIPTION
1	TRAP 0005982900
2	STRAINER ASSY 6462
3	BUBBLER HEAD 5703M
4	PUSH BTN ASS'Y PBA6
5	VALVE 5874SS
6	BOTTOM PLATE PBM1109
OPTIONAL	7 MOUNTING PLATE 6700.4
8	BOTTOM PLATE PBM1105
9	BACK PANEL P/N 0004023580
OPTIONAL	10 DRIVER, NOZZLE .25 HEX 0002082253

# PARTS BREAKDOWN

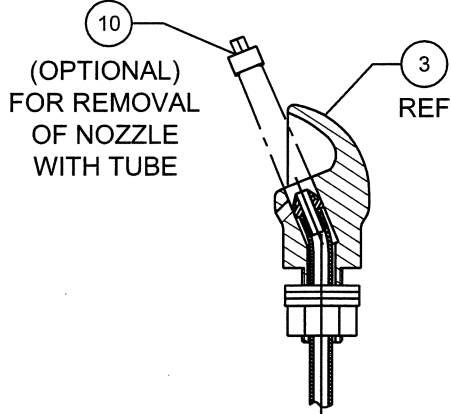
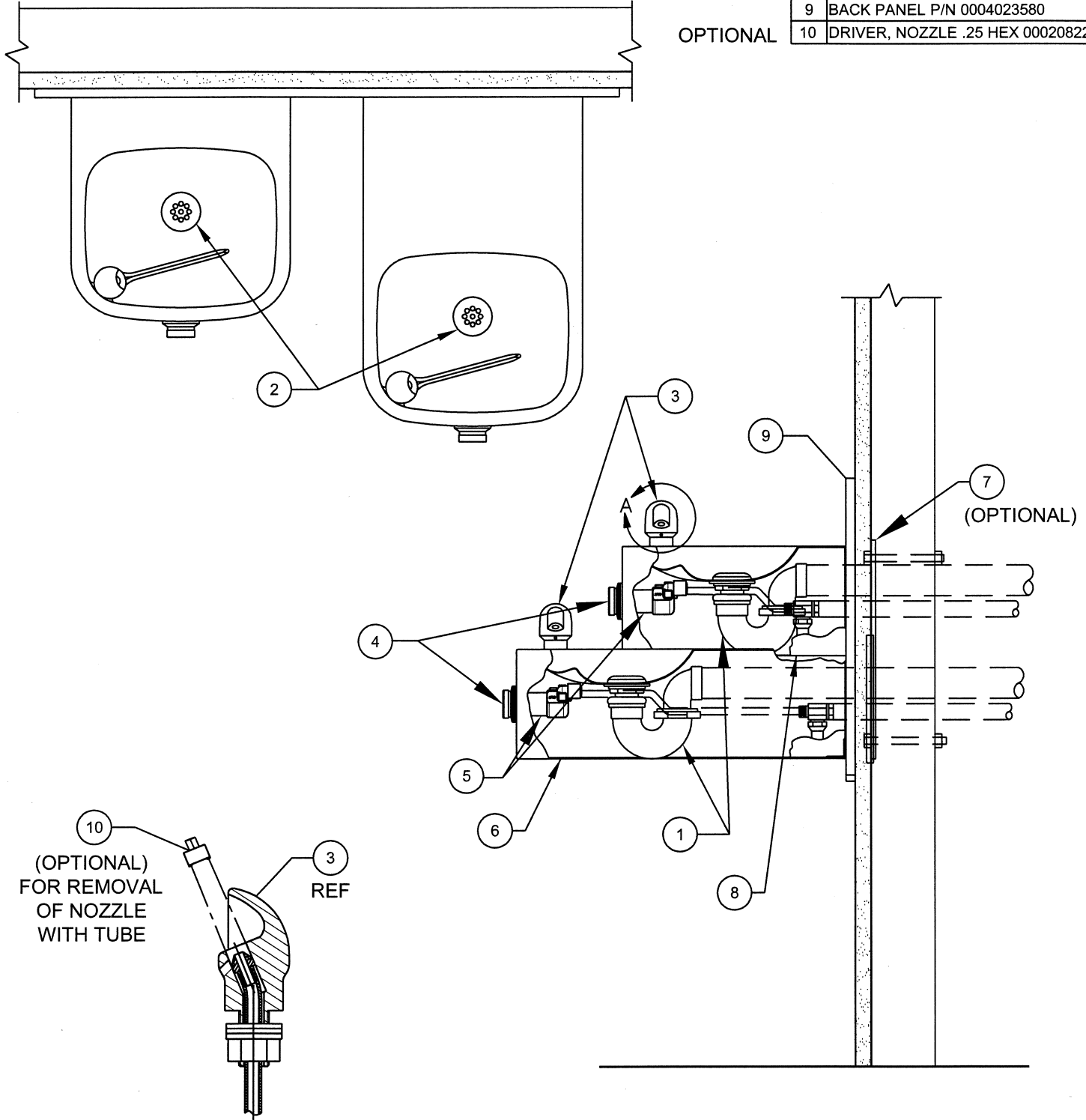

DETAIL A  
ROTATED 90° CW



**Haws**<sup>®</sup>

1455 KLEPPE LANE  
SPARKS, NEVADA 89431  
(775) 359-4712 FAX (755) 359-7424  
E-MAIL: HAWS@HAWSO.COM  
WEBSITE: WWW.HAWSO.COM

ECN NO. 4603	REVISED PER BY	DATE	CHKD	MODEL(S)										
	F. VASQUEZ	10/05/88		1119.14										
<table border="1" style="width: 100%; border-collapse: collapse;"> <tr> <td style="width: 50%;">DRAWN</td> <td style="width: 50%;">DATE</td> </tr> <tr> <td>APPROVED</td> <td>DATE</td> </tr> </table>				DRAWN	DATE	APPROVED	DATE	<table border="1" style="width: 100%; border-collapse: collapse;"> <tr> <td style="width: 50%;">PART NUMBER</td> <td style="width: 50%;">REV</td> </tr> <tr> <td>0002076717</td> <td>16</td> </tr> <tr> <td colspan="2">DRAWING NO. 13380C00</td> </tr> </table>	PART NUMBER	REV	0002076717	16	DRAWING NO. 13380C00	
DRAWN	DATE													
APPROVED	DATE													
PART NUMBER	REV													
0002076717	16													
DRAWING NO. 13380C00														

WHEN ORDERING PARTS PLEASE SPECIFY MODEL NUMBER.

THIS DOCUMENT IS TRUE AND CORRECT AT TIME OF PUBLICATION. CONTINUED PRODUCT IMPROVEMENTS MAKE SPECIFICATIONS AND MEASUREMENTS SUBJECT TO CHANGE WITHOUT NOTICE.

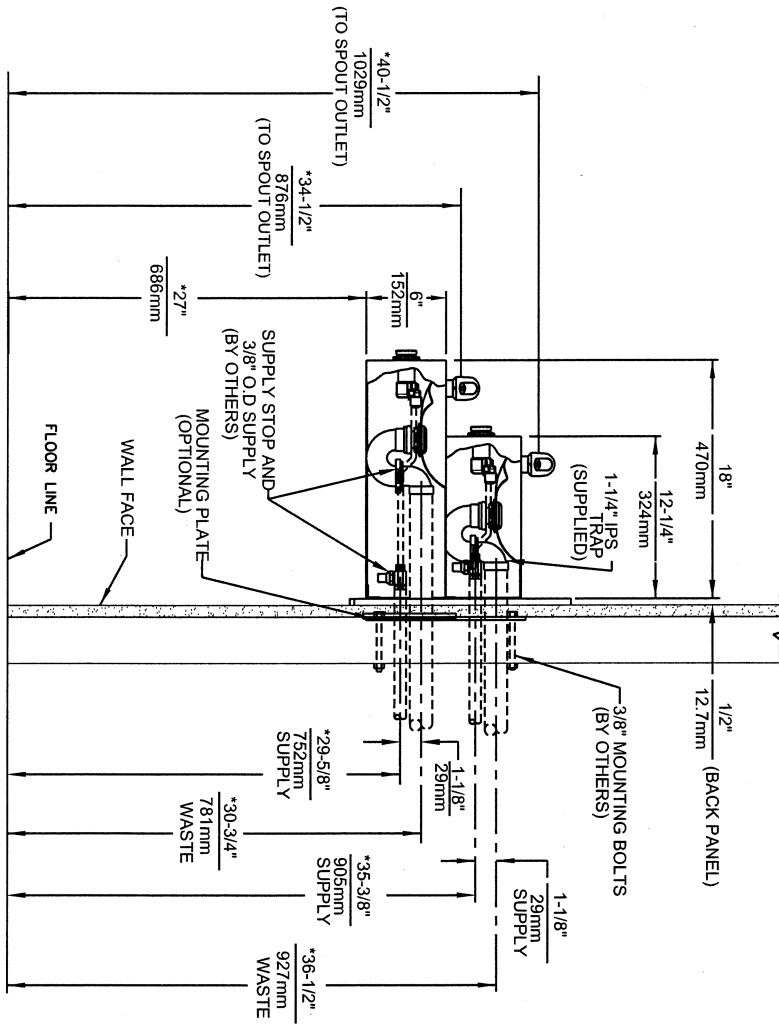
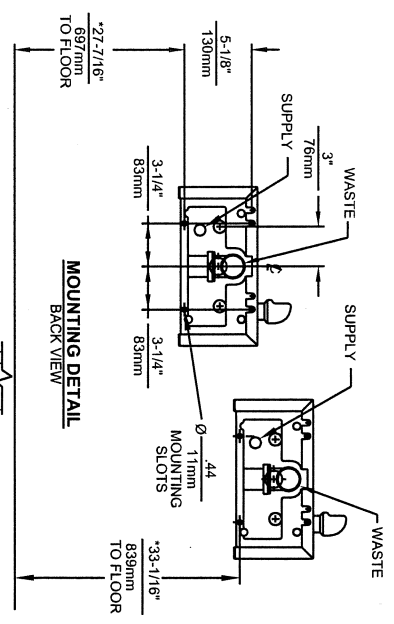
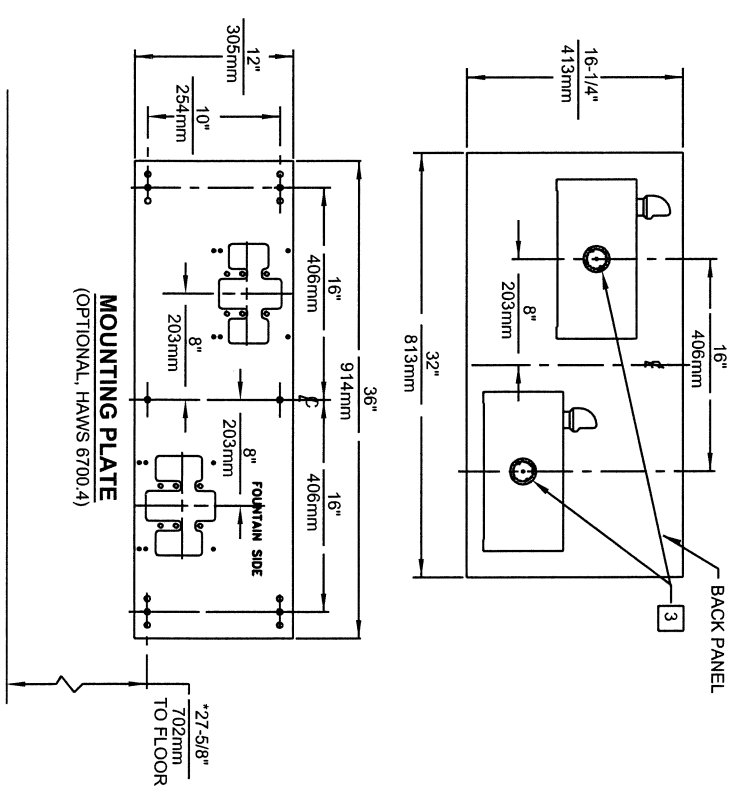
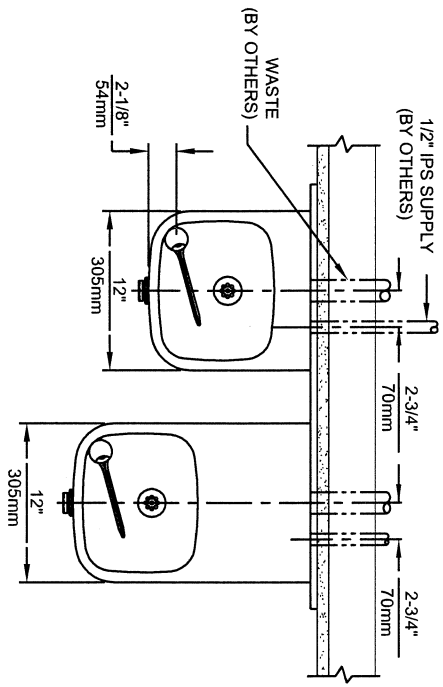

**NOTES:**

1. HOLD ROUGH-IN DIMENSIONS ± 1/4" (6.4mm).
2. WHEN INSTALLING THIS UNIT LOCAL, STATE OR FEDERAL CODES SHOULD BE ADHERED TO. FOR INSTALLATION HEIGHTS OTHER THAN SHOWN, DIMENSIONS MARKED (\*) MUST BE ADJUSTED ACCORDINGLY.
3. REFER TO 5874SSVVRK874 OPERATION AND MAINTENANCE MANUAL FOR PUSH BUTTON AND VALVE INSTALLATION/MAINTENANCE INSTRUCTIONS.

©2011 Haws Corporation - All Rights Reserved. HAWS® and other trademarks used in these materials are the exclusive property of Haws Corporation.

		<b>1455 KLEPPLE LANE</b> SPARKS, NEVADA 89431 (773) 359-4712 FAX (775) 359-7424 E-MAIL: HAWS@HAWSCO.COM WEBSITE: WWW.HAWSCO.COM
		ECN: 4603 DATE: 06/10/14 APPROVER: [Signature]
<b>MODEL(S)</b>		<b>1119.14</b>
<b>REVISION</b>		<b>INSTALLATION</b>
ECN: 4603 DATE: 06/10/14 APPROVER: [Signature]		SIZE: A 1 SHEET 1 OF 1