



INSTALLATION, OPERATION & MAINTENANCE INSTRUCTIONS

1455 Kleppe Lane ♦ Sparks, NV 89431-6467 ♦ (775) 359-4712 ♦ Fax (775) 359-7424
E-mail: haws@hawsco.com ♦ website: www.hawsco.com

No. 2076717(19)

Model 1119.14 Drinking Fountain

NOTE TO INSTALLER: Please leave this information with the Maintenance Department.

LIMITED WARRANTY

HAWS warrants that this specific product is guaranteed against defective material or poor workmanship for a period of **one year from date of shipment**. HAWS liability under this warranty shall be discharged by furnishing without charge F.O.B. HAWS Factory any goods, or part thereof, which shall appear to the Company upon inspection to be of defective material or not of first class workmanship, provided that claim is made in writing to Haws within a reasonable period after receipt of the product. Where claims for defects are made, the defective part or parts shall be delivered to the Company, prepaid, for inspection. HAWS will not be liable for the cost of repairs, alterations or replacements, or for any expense connected therewith made by the owner or his agents, except upon written authority from HAWS, Sparks, Nevada. HAWS will not be liable for any damages caused by defective materials or poor workmanship, except for replacements, as provided above. Buyer agrees that HAWS shall not be liable for general, special, or consequential damages claimed to arise under the contract of sale. The drinking fountain manufactured by HAWS is warranted to function if installation and maintenance instructions provided are adhered to. The units also must be used for the purpose for which they were intended.

**NO OTHER WARRANTIES EXPRESSED OR IMPLIED ARE AUTHORIZED,
PROVIDED OR GIVEN BY HAWS.**

**SHOULD YOU EXPERIENCE DIFFICULTY WITH THE INSTALLATION OF THIS
MODEL PLEASE CALL:**

TECHNICAL SUPPORT: 1-800-766-5612

FOR CUSTOMER SERVICE: 1-888-640-4297

RECOMMENDED TOOLS: Hack saw, pipe joint sealant, screwdriver, level, 12" adjustable wrench, 10" pipe wrench, 5/64" hex key wrench, 9/16", 1/2", 7/16" socket wrench or open end wrench.

LOCATION OF UNIT: The Model 1119.14 Drinking Fountain is a wheelchair accessible drinking water facility. The height dimensions that are shown meet current ADA requirements. When installing this unit, local, state or federal codes should be adhered to. If height other than shown is required, then dimensions must be adjusted accordingly.

SUPPLY LINE: The minimum recommended line size is 1/2" IPS with 30-90 psi (2-6 ATM) pressure. Where sediment or mineral content is a problem, an inlet filter is recommended.

PLUMBING CONNECTIONS: Inlet is 3/8" push-in type fitting. Waste outlet is female 1-1/4" IPS.

MAINTENANCE: Periodically clean the strainer. Refer to 5874 Series Valve Manual for more information.

INSTALLATION PROCEDURE

GENERAL NOTES:

1. For all plastic push-in type fitting connections, only connect NSF-61 copper or plastic tubing. Stainless steel or glass tubing is not recommended. The following assembly instructions must be followed to ensure a watertight connection:
 - a. Cut tubing square and clean.
 - b. Mark from end of tube the length of insertion (See table below).
 - c. Push tube into the fitting until it bottoms out.
 - d. To remove, depress collet and pull tubing out.

Tube Sizes	O.D. Tolerance	Insertion Depth
1/4"	±.005"	11/16"
3/8"	±.005"	3/4"
1/2"	±.005"	7/8"

TROUBLESHOOTING

PROBLEM	REPAIR CHECKLIST
1. Insufficient bubbler flow.	1a. Check that inlet screwdriver stop valve is wide open. Turn counter-clockwise. 1b. Verify minimum 30 psi flowing supply pressure. 1c. Clean strainer. See 5874 Series Valve Manual 1d. Adjust valve to increase flow. Use front adjust screw or see 5874 Series Valve Manual.

For more information about Haws products, see our website: www.hawesco.com

ITEM	DESCRIPTION	1119.14
1	STRAINER, WASTE ASSY	6462
2	BUTTON, PUSH, FLANGED, PCP W/ VALVE	5874PBF
3	VALVE REPAIR KIT	VRK5874
4	PUSH BUTTON ASSY, FLANGED, PCP	PBA6
5	BUBBLER HEAD ASSY, PCP	5703M
6	PLATE, BOTTOM	PBM1105
7	PLATE, BOTTOM	PBM1109
8	TRAP	0005982900
9	BACK PANEL	0004023580
* 10	PLATE, MOUNTING	6700.4

* DENOTES OPTIONAL PART.

NOTES:

- 1 5874PBF (ITEM 2) INCLUDES VRK5874 CARTRIDGE ASSEMBLY (ITEM 3) AND PBA6 FLANGED PUSH BUTTON (ITEM 4).
- 2 ENSURE TUBE IS DISCONNECTED FROM PUSH BUTTON VALVE BODY PRIOR TO REMOVAL. APPLY ONE DROP OF LOCTITE 222MS TO NOZZLE THREADS PRIOR TO FASTENING BACK ONTO BUBBLER HEAD. RE-ATTACH TUBE TO VALVE.

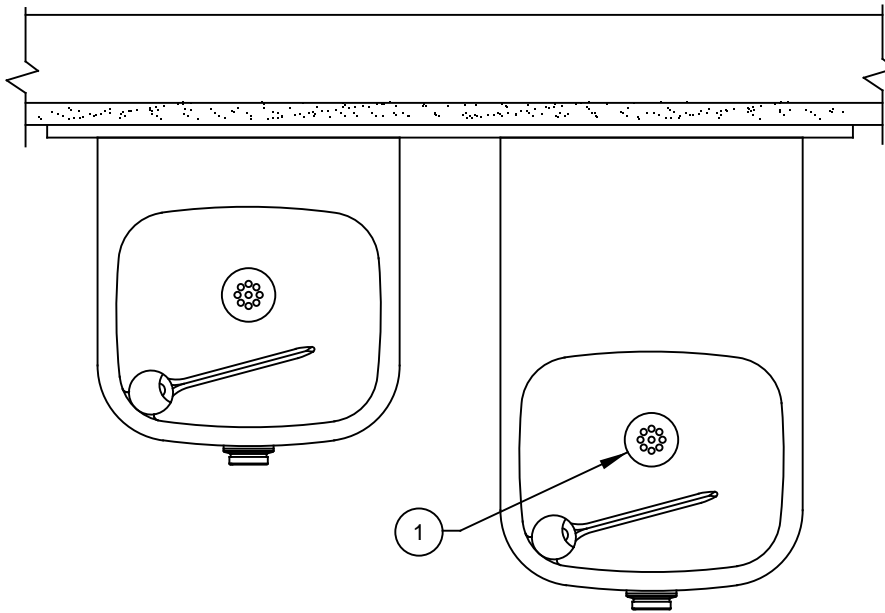

2 REMOVE INSERT WITH 5/16 HEX SOCKET (NOT SUPPLIED)

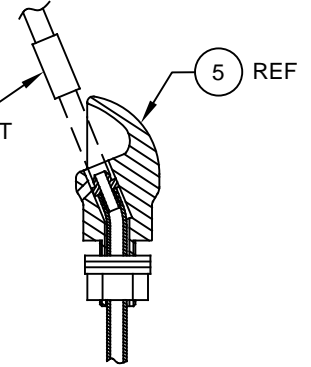

DETAIL A
ROTATED 90° INTO VIEW

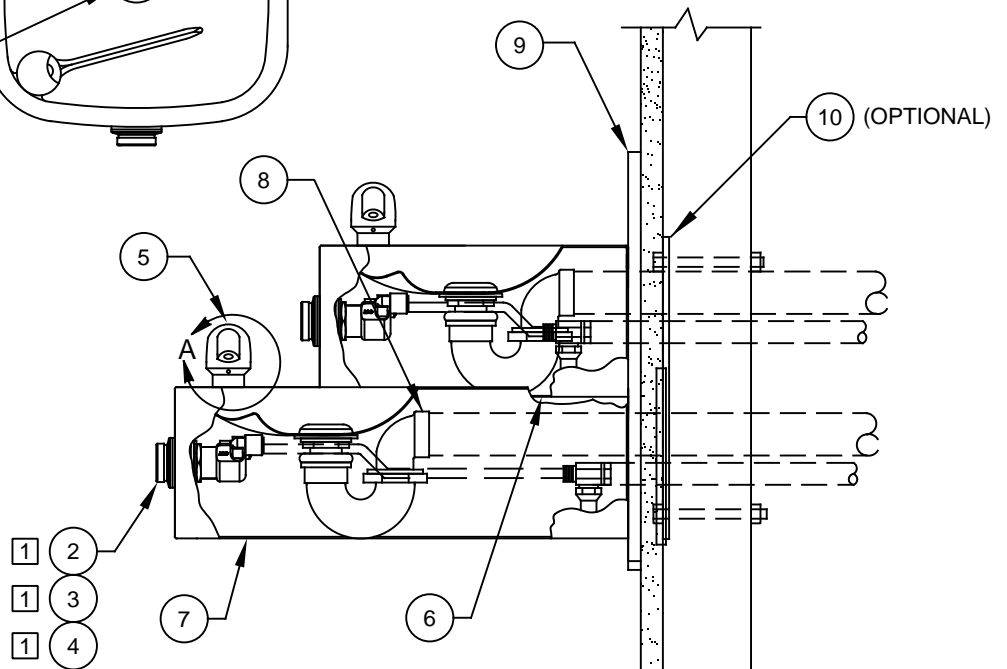

PARTS BREAKDOWN

WHEN ORDERING PARTS PLEASE SPECIFY MODEL NUMBER.

		1455 KLEPPE LANE SPARKS, NEVADA 89431 (775) 359-4712 FAX (775) 359-7424 E-MAIL: HAWS@HAWSCO.COM WEBSITE: WWW.HAWSCO.COM	
		ECN NO. REVISED PER BY ECN: 5124 VWC	MODEL(S) 1119.14
DRAWN f. DATE 06/06/98 CHKD VWC	APPROVED FV DATE 07/06/17	SCALE: 1:1 DRAWING TYPE: PARTS BREAKDOWN	REVISION 19
		SIZE: A SHEET 1 OF 1	

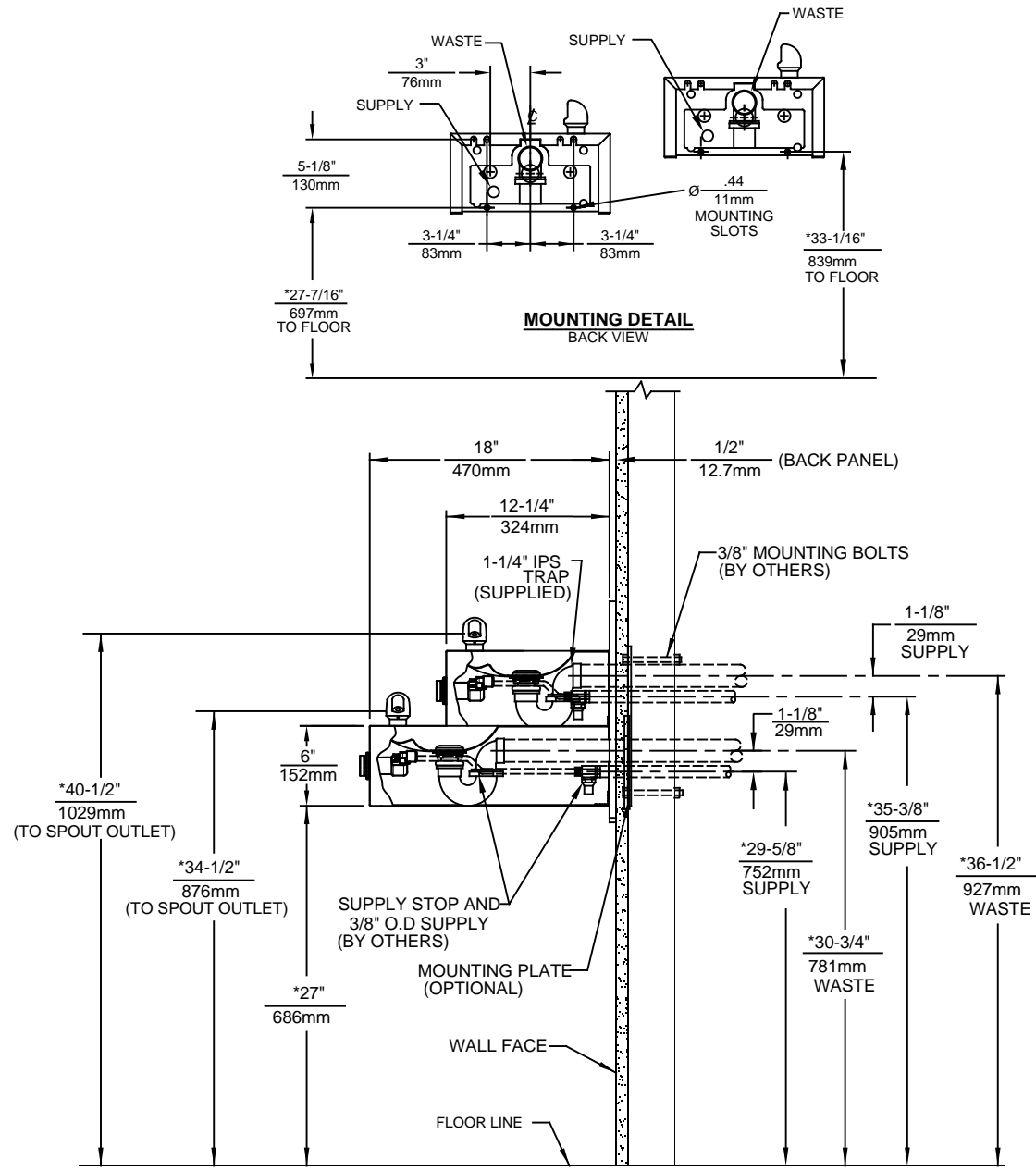
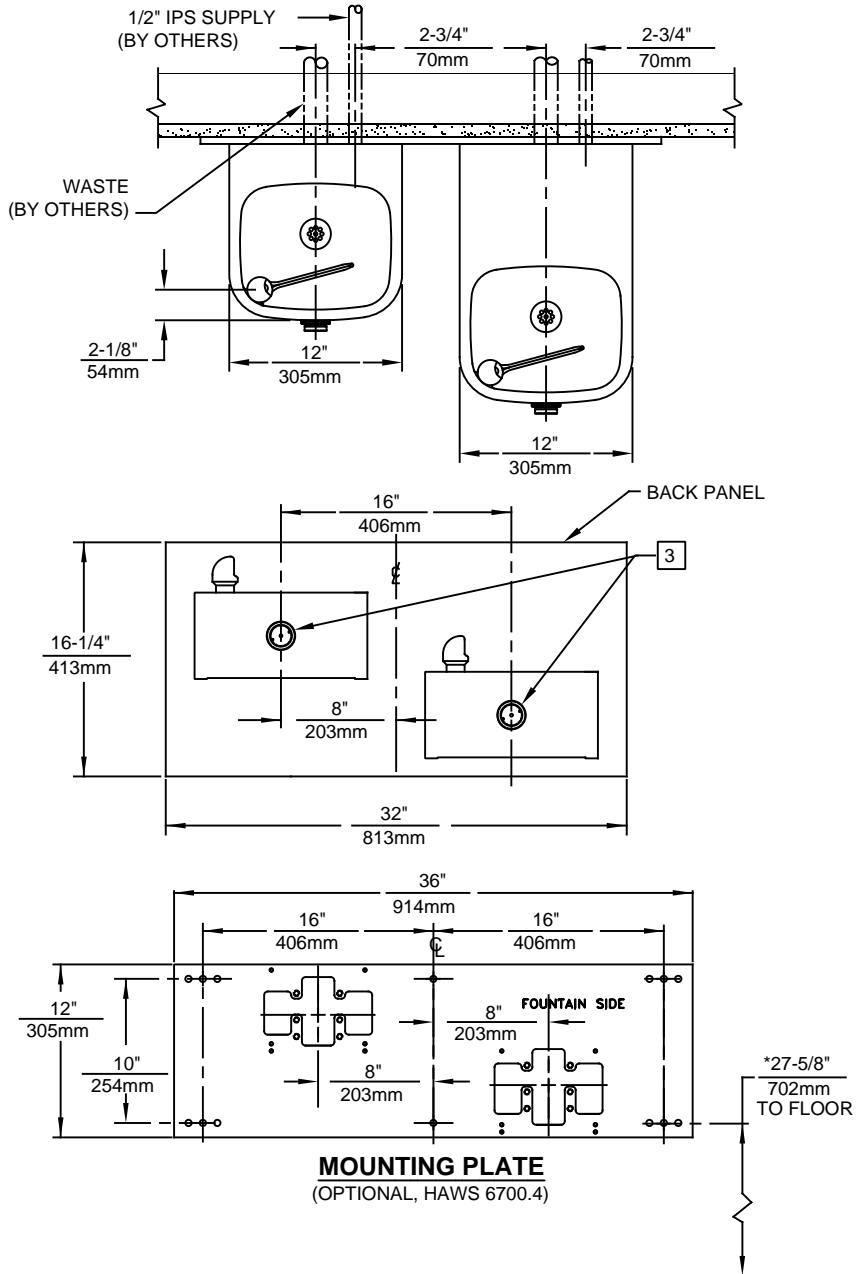

NOTES:

1. HOLD ROUGH-IN DIMENSIONS ± 1/4" (6.4mm).
2. WHEN INSTALLING THIS UNIT LOCAL, STATE OR FEDERAL CODES SHOULD BE ADHERED TO. FOR INSTALLATION HEIGHTS OTHER THAN SHOWN, DIMENSIONS MARKED (*) MUST BE ADJUSTED ACCORDINGLY.

3 REFER TO 5874 SERIES OPERATION AND MAINTENANCE MANUAL FOR PUSH BUTTON AND VALVE INSTALLATION/MAINTENANCE INSTRUCTIONS.

1455 KLEPPE LANE
SPARKS, NEVADA 89431
(775) 359-4712 FAX (775) 359-7424
E-MAIL: HAWS@HAWSCO.COM
WEBSITE: WWW.HAWSCO.COM

ECN NO. REVISED PER BY:	DATE:	CHKD.:	MODEL(S)	PART NUMBER
F.VASQUEZ	04/01/04	VWC	1119.14	0002076717.D
APPROVED:	DATE:	SCALE:	DRAWING TYPE:	REVISION
FV	07/06/17	1:14	INSTALLATION	19
			SIZE: A	SHEET 1 OF 1